

opened rose is more difficult to spray with wax, but when cool the petals can be moved to any desired position. A rosebud is comparatively simple, requiring only to be dipped. Leaves and other objects of a similar shape need not be waxed if the graphite will adhere without. Copper-coated flowers are now being used as hat pins, and make very artistic Christmas presents.

The best form of atomizer to use is one composed of two tubes at right angles to each other, the vertical one being inserted in the hot wax, which can be kept in a water bath. By blowing in the horizontal tube, a fine spray of wax will cover the flower.

In order to obtain an even coating on the object, a good method is to have two copper wires from the carbon, and hang a piece of copper on each side. If this is not done, the object must be turned at intervals.

**ORNAMENTAL CONCRETE FLOWER POTS AND HOW TO MAKE THEM.**

BY RALPH C. DAVISON.

The majority of people know something of concrete and of its advantages for a building material, especially where strength and fire-resisting qualities are a

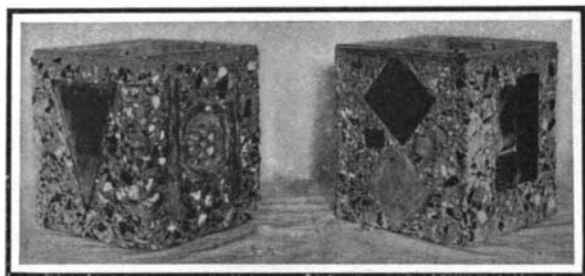

**THESE ORNAMENTAL FLOWER POTS MAKE EXCELLENT CHRISTMAS PRESENTS.**

factor. Few however know of the wonderful ornamental possibilities which can be obtained with it by a little ingenuity in the selection of the proper aggregates and the imbedding of tile arranged in varying designs.

A most interesting example of this work, the conception of Mr. Albert Moyer, is displayed in the permanent exhibition hall of the Concrete Association of America, New York. Here are to be seen a number of highly decorative flower pots. These look as though they were difficult to produce, but they are simple to make when one knows how.

Concrete is a mixture of cement, sand, and stone; to this is added the proper amount of water and the whole is then worked into a pasty mass. Thus the concrete mixture being of a plastic nature, can be molded or cast into any desired form.

Therefore the first thing to do is to prepare a mold in which the pots are to be cast. A detailed drawing for a pot 9 inches square by 10 inches high is shown in the accompanying illustrations. Use wood not less than 1/2 inch thick, 3/4 inch or 1 inch would be better. The outside form, Fig. 1, should be made first. This is nothing but a wooden box with the top left off and the bottom nailed on from below. Use as few and as small nails as possible. Three on each side will be

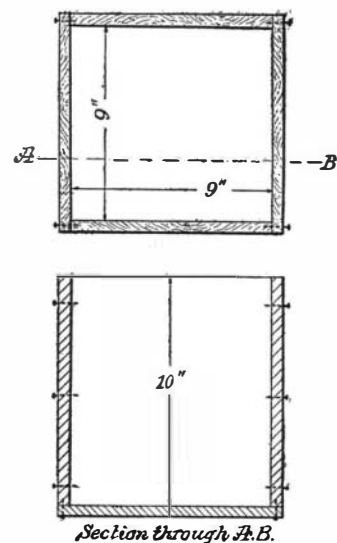
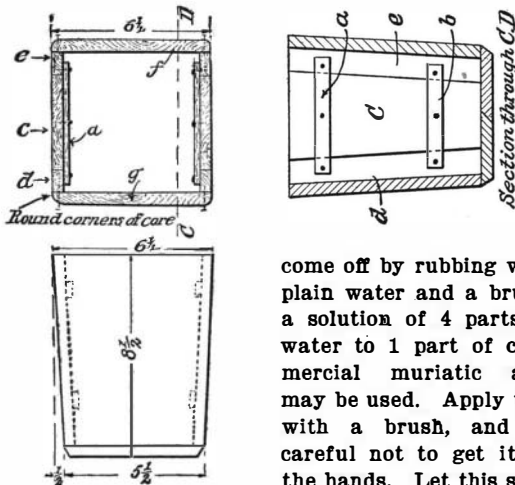

**Fig. 1.—THE OUTSIDE FORM OF THE FLOWER POT MOLD.**

plenty, as indicated in the illustration. The core, which is shown in Fig. 2, is the most difficult part to make. It is in the form of a tapered box, and must be made of sections as indicated, so that it can readily be removed after the concrete has set or hardened. After completing the mold, the concrete mixture should be made up. This should consist of 1 part Portland cement, 1 part good clean sand, and 4 parts of an equal mixture of marble chips and trap rock varying in size from 1/2 inch to 3/4 inch. If marble is not available, very effective results can be obtained by using broken brick with the trap rock. Mix the sand and cement together thoroughly while dry, wet down the marble and trap rock by dipping it in a pail or sprinkling with water, and then add it gradually to the sand and cement, thoroughly mixing the whole, and at the same time adding enough water to make it the consistency of a good heavy cream.

The next operation after mixing is the pouring or placing of the plastic concrete into the mold. This is done as follows: First fill the mold solid up to a level with the bottom of the core, pack the cement down well, and then place the core box in position,

as indicated in Fig. 3. Be sure that it rests solid on the concrete which is already placed, and that it is centered in the box. This is important, for if the core is not exactly in the center, the sides of the pot will not be of equal thickness. A good way to center and secure the core in position is to nail a strip of wood to it, and in turn nail the ends of this strip to the top of the outside form, as shown in Fig. 3. This will also keep the core down in place. After the core has been placed, and secured as above, fill the rest of the mold with the plastic concrete, packing it or ramming it down well with the blunt end of a stick. When the concrete mixture reaches the top of the mold, smooth it off nicely, and set the mold and its contents on a level place to let the concrete set or harden. In twenty-four hours from the time of pouring (do not let it be longer than this, for if so the concrete will be too hard for treatment) the concrete will be sufficiently hard to remove the molds. This should be done carefully, in order not to break the corners, as the concrete is yet more or less soft. First remove the bottom and then the sides of the outer mold. These should come off easily, unless there have been too many or too long nails used. As yet do not attempt to take out the core, as the concrete is not hardened, and the core will help to hold it up. After removing the outer forms, the surface of the concrete will appear comparatively smooth and uninteresting. The next operation is to wet the concrete surface down lightly by dashing water on it, and then to gently scrub it with a stiff brush, such as an ordinary house scrubbing brush. This operation will remove all of the surface cement and will expose the aggregates, that is the pieces of trap rock and marble which were used in the mixture, thus producing a surface similar in some respects to a black and white mosaic. If it is found that in some places the surface cement will not



**Fig. 2.—DETAILS OF THE CORE BOX.**

come off by rubbing with plain water and a brush, a solution of 4 parts of water to 1 part of commercial muriatic acid may be used. Apply this with a brush, and be careful not to get it on the hands. Let this solution remain on the surface for 15 minutes, and then scrub again with clean water and rinse thoroughly. This will leave a good, bright, clean surface, each stone sticking out boldly and free from all surface cement.

After the surface has been treated thus, the pot should be put away for two or three days to dry out and harden. The core can then be removed. This should be done as follows:

First remove the small strips a b, which have been nailed from the inside, as indicated in Fig. 2. On removing these the V-shaped section c will be released from the sections d e and can be forced toward the center of the pot and drawn out. After these V-shaped pieces have been removed, the sides f will be free and can be collapsed toward the center, and in turn can be removed. The bottom, which is made in two pieces, as shown, will then release itself freely. Before pouring the concrete mixture it is well to grease all parts of the mold, which come in contact with the plastic concrete, with a heavy oil or vaseline. This will prevent sticking, and will allow the mold to be released readily from the concrete after it has set up or hardened.

Many will probably ask why it is necessary to have a collapsible core. Why will not a plain, solid box do? The reason for this is that in pouring your wet concrete mixture, more or less moisture is absorbed by the wood mold, thus causing it to swell. If the core were made solid, it would be next to impossible to remove it without cutting it to pieces.

Therefore, in order to prevent any undue strain on the fresh concrete by hammering or cutting on a solid core in order to remove it, and also in order to be able to save the core, so that it can be used over and over again for other casts, it is always better to make a collapsible core, as shown in Fig. 2.

So far the method of procuring a mosaic effect has only been explained. But by exerting a little artistic taste, by the incorporation of colored tiles in pleasing designs, one can produce some very interesting and really striking results.

There are various means which can be employed for inserting the tiles in the outer surface of the pots. One is to place in the outer mold a negative mold.

This is done by cutting out a piece of wood the exact shape but a trifle larger than the tile which is to be inserted, and nailing it in the desired position to the inside of the outer mold. On drawing the outer mold this will leave a cavity in the outer surface of the pot, into which the tile can be cemented. In cementing the tile in place, the surface of the pot as well as the tile itself should be well soaked with water. Use a mortar composed of 1 part cement to 1 part fine sand. Another method for placing the tiles is to bore small holes through the outer forms, and secure the tiles to the inside of the outer forms by tying with string, as indicated in the illustration; care being taken to see that the ornate side of the tile is placed next to the wood. Then pour in the plastic concrete as you would proceed to do in an unornamented pot. Before removing the outer forms in this case, however, the strings which hold the tile in place should be cut. This is

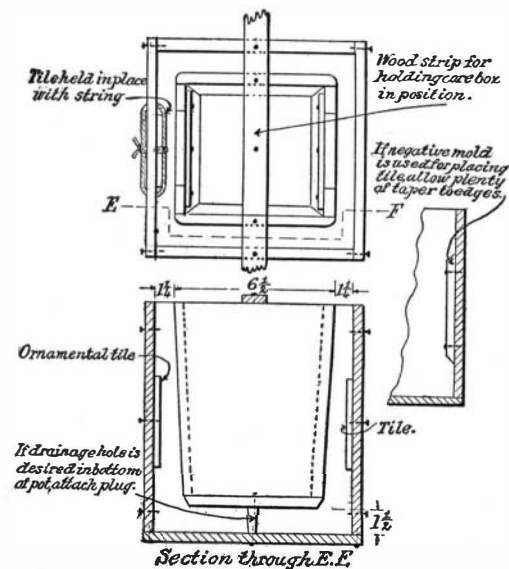

**Fig. 3.—THE MOLD ASSEMBLED FOR THE PLACING OF THE CONCRETE.**

perhaps an easier method of placing the tile than that of making a negative mold. But in some cases it is hard to get the plastic concrete to flow completely around the tile. If in removing the forms, however, it is found that there are some places where the concrete has not run up to the tile, these holes or "voids," as they are called, can be filled in or pointed up by cementing small pieces of stone in them. Anyone making a vase or pot after the above directions will be amply repaid for his trouble; for the work is interesting, and is suggestive of an unlimited number of designs and combinations, each of which will contain more or less individuality.

**HOME-MADE METAL LAMP SHADE.**

BY B. A. JOHNS.

The accompanying sketches show a simple and yet effective way to make a metal lamp shade. When the desired size, shape, and general style of the shade is selected, a diagram is made, from which the blanks or sections are made. The blanks are cut out from some thin metal, such as copper, brass, or black iron, with a small strip on one side, as indicated in dotted lines in Fig. 3. This flap is to be turned in and soldered to the adjoining blank.

Now trace the desired design on the blank, which may be a conventional flower or anything that ap-

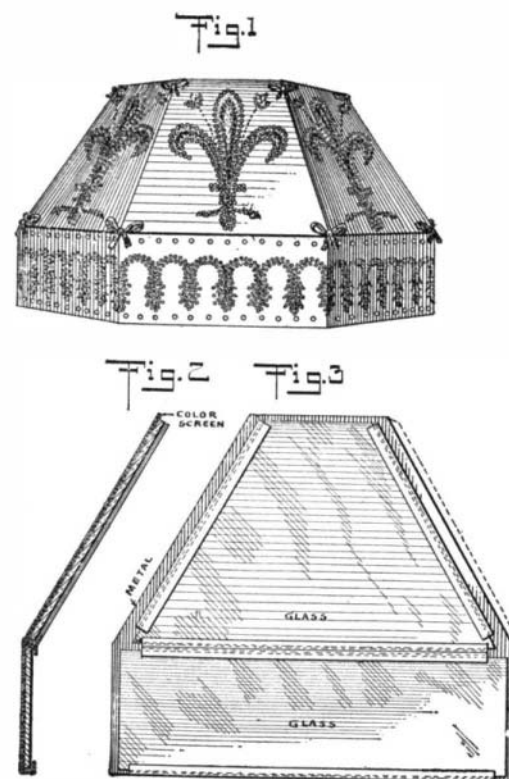

**HOME-MADE METAL LAMP SHADE.**