

BRAKE FOR BOB SLEDS.

The sled which is shown in the accompanying engraving consists of a pair of bobs, which are connected together in such a manner that upon relaxing the draft strain, or causing the draft animals to hold back the front bob, a positive braking action will be effected. In the illustration the forward bob is shown at A, and the rear bob at B. The upper rails of the

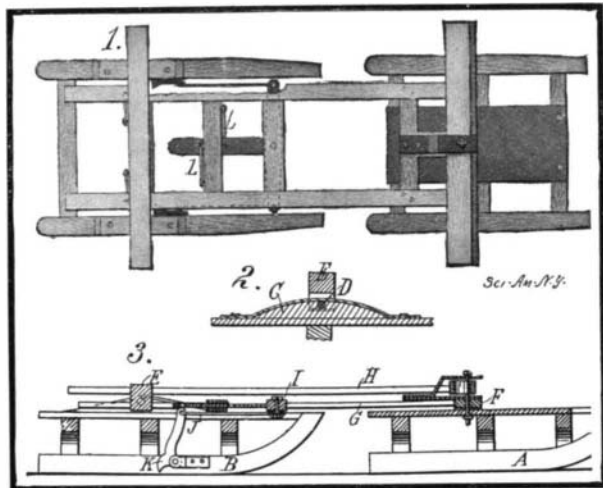

BRAKE FOR BOB SLEDS.

rear bob are formed with curved reinforcing pieces C, which are slotted to receive the pins D (Fig. 2). These pins D are fitted into the bolster E, providing a rocking connection between the latter and the bob. The forward bob is provided with a bolster F, which is connected to the rear bolster by means of side bars G. The latter are not fixed to the bolster E, but are slidably engaged therewith. Above the bars G is an auxiliary bar H, rigidly connecting the bolster E to a slotted bolster above the bolster F. A coupling pin connects the bob A with the two bolsters. In operation, when the strain on the forward bob is relaxed, there will be a relative motion between the two bars H and G. The bars G are connected to a cross piece I, which in turn is connected by links J to a brake arm K. When the rear bob rides forward with respect to the front bob, the brake arms K, which are pivoted to the rear bob, are swung on their axes by the relative motion of the bars G with respect to the bars H. Each of the brake arms is formed with a curved toe, which by this action is brought in contact with the ground, retarding the motion of the rear bob. The cross arm I may be adjusted with respect to the bars G, and secured by the hooks L. This mechanism is particularly adapted for use on bobs that carry heavy loads. The inventor is Mr. Eben G. Doland of Starksboro, Vt.

WATERPROOF FUSE CAP.

The invention which is illustrated in the accompanying engraving is adapted to be attached to the fuse of an explosive cartridge, such as is used in blasting in mining. The purpose of the attachment is to keep the end of the fuse substantially water-tight, so as to prevent the occurrence of "miss-fires" or "miss-holes" in blasting, which are due largely to the fact that the explosive in the cartridge becomes wet. The fuse cap consists of a shell A, which is closed at one end, while the other end is slitted to form a series of leaves. The ends of these leaves are bent back, as indicated at B, and are provided with projections C, extending inward. These projections are preferably formed by cutting V-shaped pieces in the turned-back portions of the leaves, and bending them inward at right angles to the leaves. Fitted over the shell A is a clamping collar D. Normally the leaves are sprung outward, and the collar D, when it is slipped over them, serves to draw them inward, pressing the projections C into the fuse F. Fitted over the fuse and

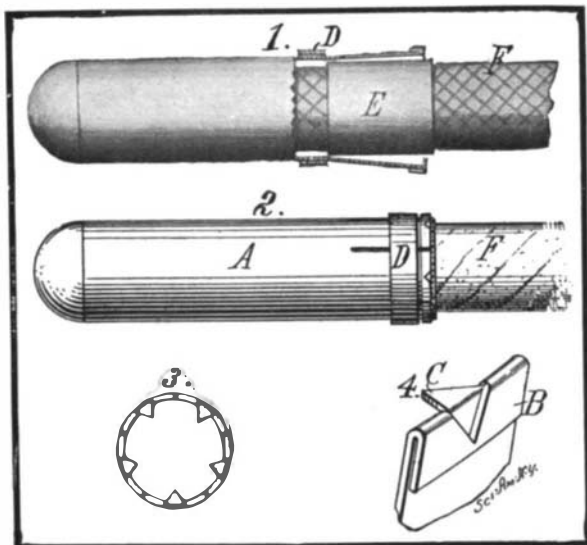

WATERPROOF FUSE CAP.

under the leaves of the shell is a rubber sleeve E. This serves to prevent moisture from entering the shell through the slits. The projections C press into the fuse at the outer end of the rubber sleeve, so as to prevent the latter from working out. Mr. Thomas N. Daniels of Valdez, District of Alaska, has been granted a patent on this waterproof fuse cap.

NOVEL TYPE OF PLOW.

The plow which is illustrated in the accompanying engraving is designed to open up the ground below a furrow, so as to form a conduit in which the moisture will be retained and an excess of moisture will be drained off. In times of drought, the circulation of the air beneath the roots of the plants will draw down any moisture in the atmosphere, and promote their growth. After a fairly good rainfall, the conduit below the furrow will accumulate a certain amount of water, which will be sufficient to keep the roots of the plant moist. The plow is of very simple construction, and quite similar to the ordinary. It consists of a beam A, with the usual handles B, but the plowshare C is designed to travel entirely underground. The form of the plowshare is preferably circular in cross section, and is tapered at its forward end in such direction as to hold the share down in the ground. To prevent the share from digging down too deeply, a guide D is provided, attached to the beam A, which is formed with a pair of flanges that rest on the surface of the ground. We are informed that this plow has been in use, with very favorable results. The crops which have been grown over these underground conduits have shown a remarkably increased yield. The plow can be attached behind an ordinary rotary plow, thus reducing the expense of operating it. The inventors of this plow are Messrs. S. F. Vose and C. R. Harryman of Shawnee, Okla.

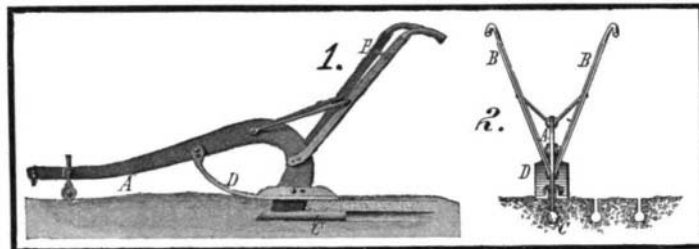

NOVEL TYPE OF PLOW.

close to the handle of this bar. When the handles are operated, the two bars move toward and from each other with a parallel ruler motion, and the series of

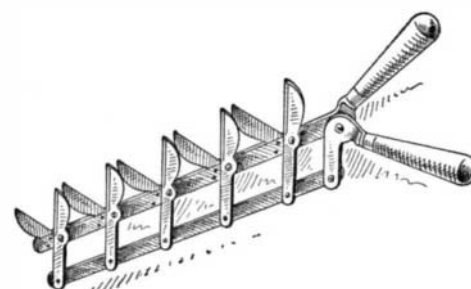

SHRUBBERY CUTTER.

cutting blades are caused to open and close, in the manner of the ordinary shears.

KETTLE TILTER.—A simple device is illustrated herewith, which may be used to tilt a kettle in which vegetables or other food is being cooked, so that it may be drained without scalding the hands. The device consists of a pair of wire arms, which may be fitted to grip the edges of the kettle. These arms are provided with a pair of handles, which are crossed under the ball of the kettle. A third handle may be seized in one hand, while the other two handles are grasped in the other hand. The kettle will thus be firmly gripped, and it may be tilted to any desired degree with perfect safety.

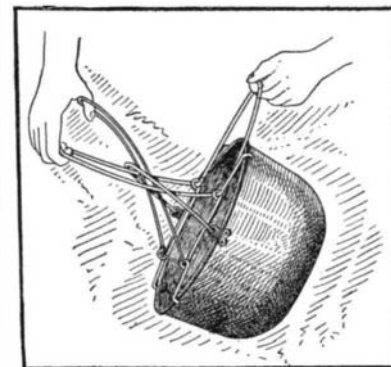

KETTLE TILTER.

AUTOMATIC LAMP EXTINGUISHER.—An inventor residing in South Dakota has invented a simple device, which may be attached to an oil street lamp such as is used in a village or town, to extinguish the light at any hour set. The device consists of a sleeve which is arranged to slide over the wick, to extinguish the lamp. This sleeve is connected by a rod to an alarm clock. A pinion on the winding key of the alarm engages a rack carried by the rod. When the hour arrives for the light to be extinguished, the alarm mechanism is disengaged, causing the key to turn in the usual way and thereby feed the sleeve upward, so that it covers the wick and extinguishes the flame.

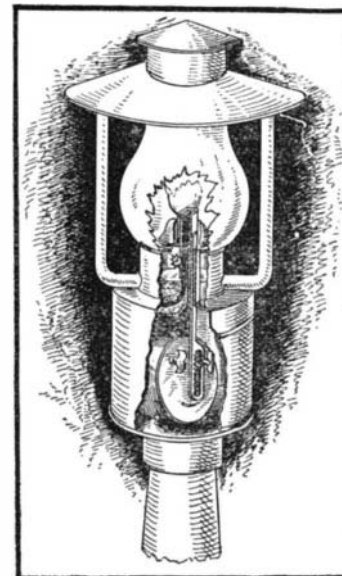

AUTOMATIC LAMP EXTINGUISHER.

ODDITIES IN INVENTION.

COVER FOR FRYING PANS.—An inventor in Chicago has devised a frying pan with a cover which may be raised, whenever it is desired to examine the contents

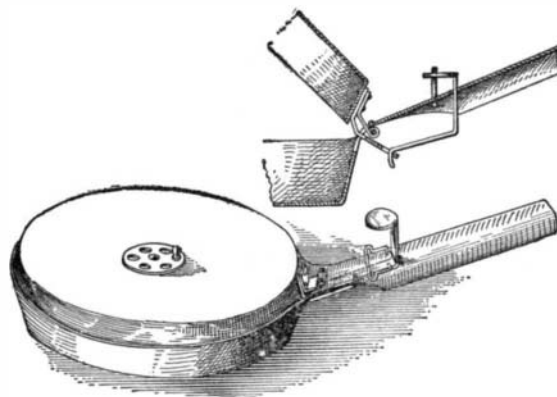

COVER FOR FRYING PANS.

of the pan, without danger of burning one's fingers. The cover is formed with an extension, which passes through the handle of the pan. A thumb piece is attached to this extension, and passes vertically through to the upper side of the handle. The cover may then be opened by depressing the thumb piece. Hinged to the handle is a catch, which may be swung over the thumb piece to hold the latter in its depressed position when it is desired to keep the cover of the pan open.

SIMPLE WIRE FASTENER.—Pictured herewith is a simple device for fastening fence wire, or the like, to posts. The advantages of this fastener are that it may be placed in position on the post before the wire is attached thereto, and that its construction is such as to prevent the wire from being accidentally disengaged from the fastening. The fastener is stamped out of sheet metal and is formed with two spurs, one of which is barbed to prevent it from leaving the post after it has been driven in. The projecting part of the fastener is formed with a spiral opening, into which the wire is introduced. A pair of coating shoulders at the en-

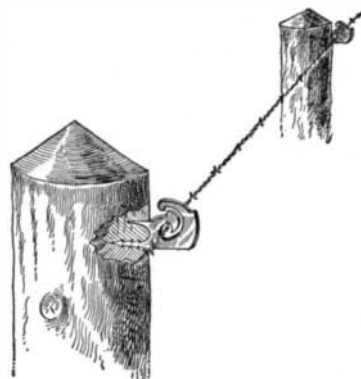

SIMPLE WIRE FASTENER.