

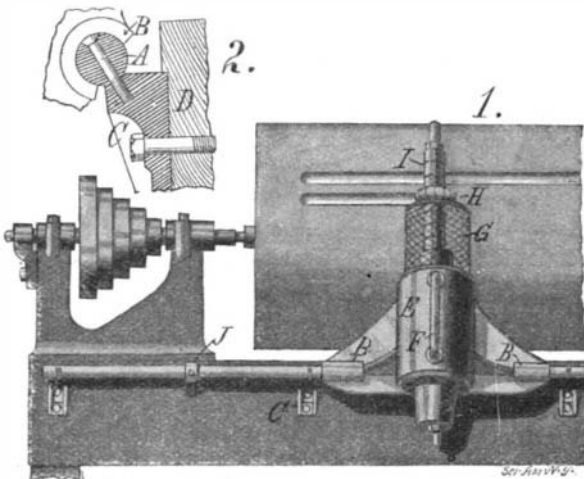

FLUTING AND BEADING ATTACHMENT FOR LATHES.
 Pictured in the accompanying engraving is an attachment that can be applied to a woodworking lathe,



FLUTING AND BEADING ATTACHMENT FOR LATHES.

to form flutes or beads on columns and the like. The construction comprises a guide bar *A*, on which is mounted a casing *B*. The guide bar is supported at suitable intervals on brackets *C* which are fastened to the body *D* of the lathe. Fitted in the casing *B* is a motor *E*. The armature shaft of this motor extends upward and carries a cutter *H* which is of suitable form to cut the flutes or beads. This cutter may be secured at any desired point on the armature shaft by fitting a number of washers *I* above and below it and clamping them in place with a nut threaded on the end of the shaft. An adjusting screw is fitted under the motor *E* and engages the casing *B* in such manner that it may be operated to adjust the motor with respect to the casing and thus raise or lower the cutter *H*. The motor is provided with a handle *F* which enables the operator to slide the motor along the guide rail and to swing the motor on the guide rail so as to move the cutter *H* into engagement with the work. To protect the workman from the moving parts of the machine, a wire screen *G* is provided. On the guide rail *A*, stop collars *J* are fitted which may be secured by means of set screws at any desired point to limit the motion of the motor along the rail. After the work has been turned down in the lathe it remains truly centered while being fluted or beaded so that separate handling of the work from a lathe to a fluting or beading machine is dispensed with. A patent on this improved fluting and beading attachment has been secured by Mr. C. R. Voorhies, 1509 Belmont Avenue, Mount Tabor, Ore.

COMBINED PONCHO AND TENT.

Illustrated in the accompanying engraving is a tent which, when disassembled, may be converted into one or more ponchos, thus enabling it to be conveniently transported, and making it of particular value to troops, huntsmen, and campers generally. The tent is made up of sections, preferably triangular in form. A single section may be set up as a shelter tent, as indicated in Fig. 1. Each section is provided along its side edges with buttons and buttonholes, one-half



COMBINED PONCHO AND TENT.

of each edge being formed with buttonholes and the other half with buttons, so that a section may be folded upon itself, and buttoned together to form a bag. In the center of each section is a slit, provided with an elastic neck band, and when the section is formed into a bag it may be slipped over a person, with his head fitted through the slit. Armholes are formed at a convenient location on the section, and thus the section may be converted into a poncho, as shown in Fig. 3. When a number of hunters are provided with ponchos of this description, the sections may be buttoned together to form a larger tent of the Sibley type, as shown in Fig. 2. The material of the tent is waterproof, so that it provides the hunter with a weather-proof garment. The inventor of this combined poncho and tent is Mr. Frank H. Gotsche of 416 Hoffman Avenue, San Francisco, Cal.

PLOW FOR TURNING THE SURFACE SOIL UNDER THE SUBSOIL.

The plow which we illustrate herewith is arranged to cut two slices of soil as it passes through the earth, one from the surface soil and one from the subsoil. The first layer is turned over into a ditch cut by the previous run, while the second layer of subsoil is turned over on to the first layer. In this way seeds and weeds are completely buried, while the rich subsoil is brought to the surface. The plow is formed with two shares, one placed in front of the other, and the rear one making a deeper cut. The forward share is of such form as to force the layer of soil it cuts to one side, and at the same time turn it over. The form of this share is shown in the drawing. It is provided with a downwardly projecting guide fin *A*, which is curved and offset outwardly. The body of the moldboard *B* inclines upward and outward, and terminates in a curved bow or horn *C*. The horn *C* extends completely over to the outer side of the furrow, and runs

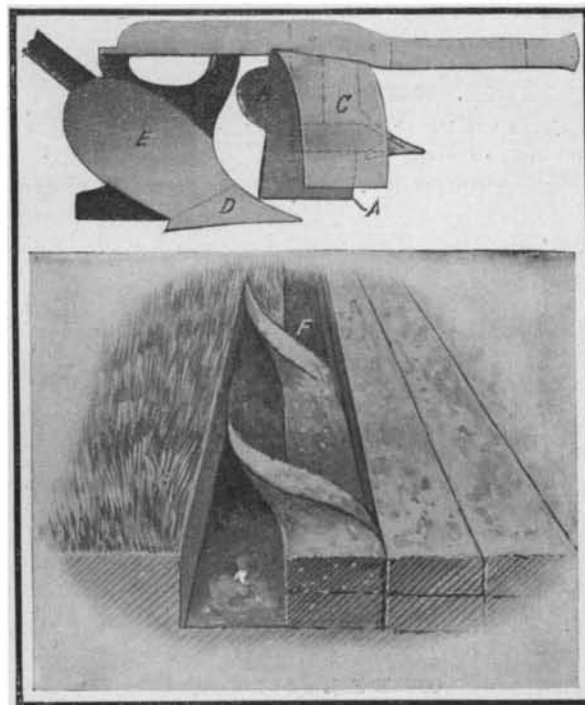

PLOW FOR TURNING THE SURFACE SOIL UNDER THE SUBSOIL.

along against the side of the furrow, acting as a guide. Immediately back of the front share is the second share *D*, which cuts into the subsoil to the rear. This is provided with the usual moldboard *E* and the guide fin *F*, adapted to hold the plowshare in the furrow. Fig. 2 illustrates the way in which the slices are cut from the earth, and turned over into the ditch or furrow *F* previously cut. A patent on this plow has been secured by Mr. Thomas Sawatzky of Herbert, Saskatchewan, Canada.

AN IMPROVED WINCH.

A recent invention provides an improved type of hoisting winch, such as used by riggers. This improved winch is constructed very simply and with a reduced amount of gearing, the latter being arranged to provide a surface for applying a brake band. It consists of a rectangular frame cast in a single piece. Mounted in roller bearings in this frame is a shaft which carries a drum *A*. This drum is formed at one end with a flange, while to the opposite end is secured an internal gear *B*. A pinion engages this gear, and the stub shaft on which this pinion is formed is provided at its outer end with a pair of slots *C*, into which is fitted a hand lever *D*. This hand lever may be freely moved in the slots, to shorten or lengthen the leverage. The advantage of this adjustment lies in the fact that, as the rope is wound on the drum, the successive layers of rope grow larger in diameter, and a longer crank is necessary to operate the winch. The rope is attached to the drum by passing it through a slot *E*, and securing it to a clip on the inside of the internal gear. The outer periphery of the gear is fitted with a brake band *F*, provided with an operating

lever, as shown. The advantage of using an internal gear is that it gives better contact of the intermeshing teeth. The large gear being applied directly to the end of the drum does away with torsion on the shaft incident to the ordinary method of placing the gears outside of the bearings. This same system of

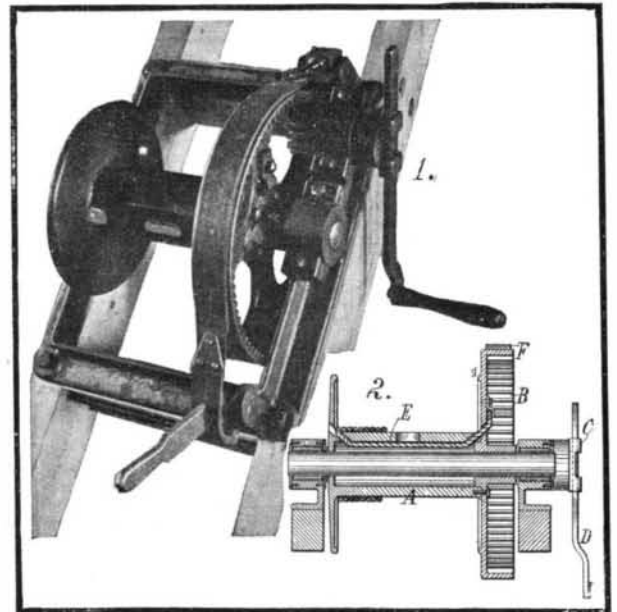

AN IMPROVED WINCH.

gearing may be used with a wheel and endless rope instead of the crank. A patent has been granted to Mr. Volney W. Mason of Lafayette Street, Providence, R. I., on this improved hoisting winch.

COLLAPSIBLE STEP-LADDER.

The ordinary step-ladder is arranged so that the supporting legs may be folded against the ladder proper, but the ladder here illustrated is arranged to be further folded, so that the sides will collapse one against the other. In this way the ladder will be made to occupy a minimum of space, facilitating storage or transportation. All the parts are connected, while in the collapsed position, so that the ladder may quickly be set up for use as shown in Fig. 1. The treads or steps *A* of the ladder are hinged at each end in the skeleton side rails *B*. The supporting legs *C* are hinged to the side rails in the usual way, and are provided with braces *D*, which serve to hold them in their open position. The supporting legs are connected by means of cross pieces *E*, which are pivoted thereto, and the two legs are kept apart by means of a diagonal brace *F*, which is provided with a stud that engages a slot in the cross piece *G*. By means of a thumb nut the diagonal brace may be clamped to hold the parts in the spaced position. A similar diagonal brace *H* is provided, to keep the side rails properly spaced apart. At the upper end of the ladder is a platform *J*, which is pivoted to the supporting legs, and is formed with extensions which engage the under side of one of the steps. One of the arms of the platform is provided with a slot *K*, through which the pivot pin passes, so as to permit of folding the parts. When folding the ladder this platform is first swung on its pivot, and then the supporting legs are folded against the side rails. Thereafter the thumb screws of the diagonal clamps are loosened, permitting the side rails to be folded against each other, as indicated in Fig. 2. The inventor of this collapsible step ladder is Mr. William J. Blundell of Brooklyn, N. Y., P. O. Box 182.

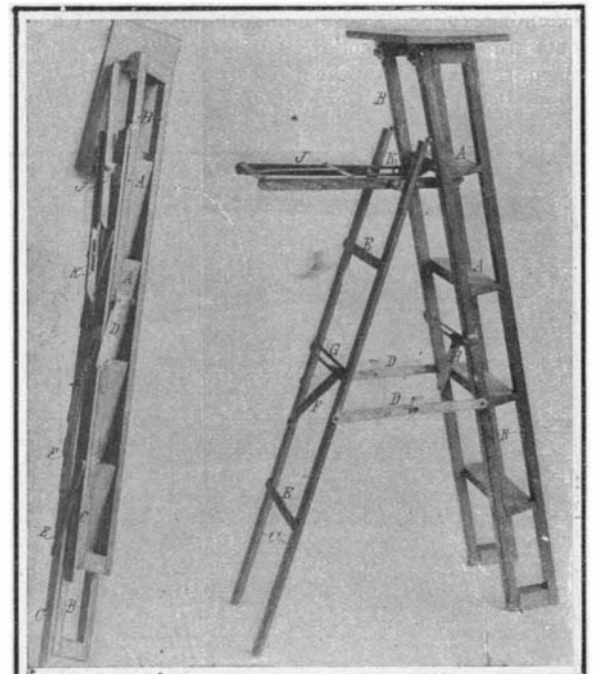

COLLAPSIBLE STEP-LADDER.