

N. E.—The writer wishes to acknowledge the assistance, in constructing this seismograph, of Prof. Marvin, of the Weather Bureau at Washington, and Prof. Milne, of the British Association Seismological Committee. Both of these gentlemen have very courteously answered questions on the general construction of such instruments.

#### A SIMPLE METHOD FOR MAKING A COILED SPRING.

BY A. FAGAN.

Get a metal rod the same diameter as the spring desired; drill a hole near the end to admit end of wire. Give the wire two or three turns around rod, spacing the turns according to the desired pitch.

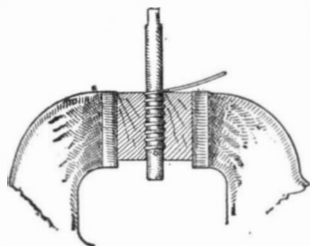

#### A SIMPLE METHOD FOR MAKING A COILED SPRING.

Clamp it between two blocks of hard wood in a vise, having the rod in the direction of the grain of the wood. Revolve the rod by means of a monkey wrench fitted on flattened end of rod. The wire will follow in and wind a spring as true and perfect as though it had been wound with a lathe.

#### A HOME-MADE WIMSHURST MACHINE.

BY JOHN R. ALLEN.

I became acquainted with two students, who were each intending to build a large Ruhmkorff's induction coil for experimental purposes. I was taking the SCIENTIFIC AMERICAN at the time, and had been reading about the Wimshurst machine. I noticed that it is very simple and cheaply made when compared to a large coil. I told the young men of it, and showed them the papers, and asked them why they did not build Wimshurst machines instead of coils. After several visits to their workshop and continued efforts to get them interested they "turned the tables" on me and said, "Why don't you build a Wimshurst machine?" And then they began to "rub it in" and repeat all I had said to them, and also hinted that I could not make one that would spark at all. I saw I would either have to build a machine or admit defeat and stand the laugh. So I went to work to build one. I did not go strictly according to the directions as laid down in the SCIENTIFIC AMERICAN SUPPLEMENT No. 548. I built the frame of oak, made the bosses of pine, got the two glass disks cut, 12 inches in diameter, used brass foil with brass hemispheres (tack heads) soldered on for sectors, sixteen on each disk. Instead of bottles for Leyden jars I used Welsbach gas lamp chimneys (the straight kind), putting the tinfoil in the middle, keeping it 1½ inches

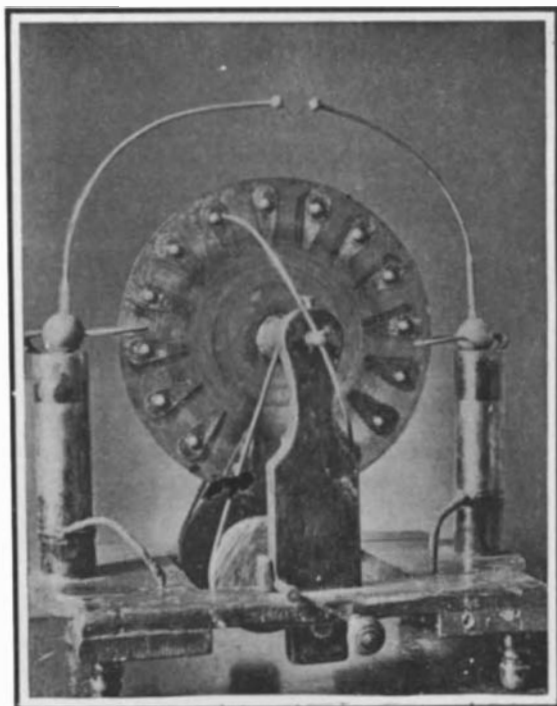

A HOME-MADE WIMSHURST MACHINE.

from each end, and then I put the posts that support the combs and terminals right through the chimneys. The posts are of hard rubber. I bored a hole into the end, and put the stem of the brass balls which connects the combs and terminals into it, and poured melted sulphur around it till the hole was full, and it makes a good fastening. The combs are connected to the inner coating of the Leyden jars. In place of

simply connecting the outer coatings of the jars together with a wire, I put two tubes into the frame in such a manner that I can connect them by putting the plug in one tube, or I can disconnect them by putting it in the other, and then put in hand bolts or any connection I like. I can also put wire in, and run it to display designs made by tinfoil strips cut at the places where the sparks are wanted to make the design or letters, etc. I used oak driving pulleys and leather cord belt. I get a 1½-inch spark when the outer coatings of the jars are connected. I photographed the machine, spark and all, by pulling down the window shades, opening the camera, and then turning the machine till it sparked several times, closing the camera, raising the window shade, and taking a picture of it in the daylight.

The students made their coils, but one of them broke down in three months and had to be rewound.

#### A BLACKSMITH'S NAPKIN RING.

A blacksmith friend recently presented the writer with a very neat dinner napkin ring, which he had made from an old steel shovel. A strip of steel was cut the proper length and width. The two ends were tapered down until their combined thickness was equal to the thickness of the body of the ring, which was bent into a cylindrical shape, and held in position by means of a piece of iron or steel wire wrapped around the outside. Since the steel was too thin to be welded, on account of losing the heat too quickly,

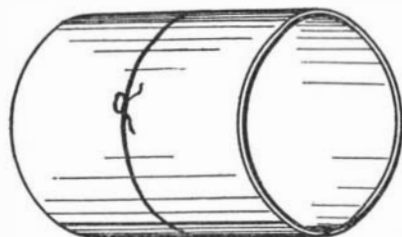

A BLACKSMITH'S NAPKIN RING.

the two ends were brazed. A thin flat piece of copper wire was put over the joint, and the ring placed upon the fire, with the joint nearest the heat. As the ring became hot, a pinch of powdered borax was thrown along the inside of it, over the joint, bringing the copper wire to the melting point, when the ring was quickly but carefully taken from the fire and dipped into a pail of water. The surface of the ring was cleaned up bright, and sent to a silversmith to be plated.

#### AN UNBREAKABLE LEYDEN JAR.

Two ordinary tin cans may be used to make a serviceable Leyden jar, which has the advantage of being unbreakable, according to Kosmos.

Select two tins such that the diameter of the one exceeds that of the other by about one-half inch. Cover the bottom of the larger tin (inside) with a disk of rubber or varnished cardboard. To the bottom of the smaller tin (on the outside) solder a piece of iron or copper wire, bent into a hook at the tip, or else ending in a ball. Around the smaller tin wind an old rubber plate or several layers of silk rags or well-varnished parchment, folding this insulating layer down into the tin over the edge, an inch or more. Place the smaller tin, thus insulated, with the edge down, in the larger can, and the Leyden jar is com-

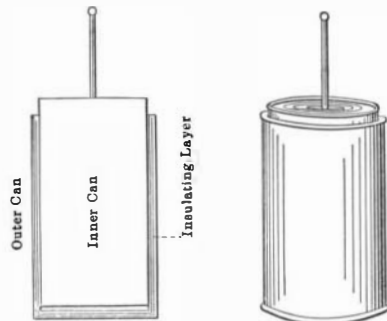

AN UNBREAKABLE LEYDEN JAR.

pleted, ready to be charged from a frictional machine or an electrophorus.

The inner tin should stand out an inch or so above the outer can, to prevent sparks from passing over.

#### A SIMPLE FOOT-POWER COMPOUND GRINDER.

BY A. E. OSBORN.

As there may be some amateur mechanics (particularly automobilists) who do not possess a grinding and polishing machine, although they would find such an appliance of considerable use, it is thought that the accompanying description and illustration of a machine made by the writer in about an hour's time and at practically no expense, might be of interest. The cheapness and ease with which it can be made are due to the utilization of certain parts of a bicycle

(which is usually available or can be obtained for a small sum second hand) for the driving mechanism, and to the employment of a convenient work bench or strong table as a stand. The bicycle should have as high a gear as possible (it is not injured, and can be reassembled and used on the road again) and should have its front wheel, forks, handle bar, and back tire removed. In order to support the remaining parts, two boards about 1¼ x 4 inches, reaching from the floor to the top of the bench, should be pro-

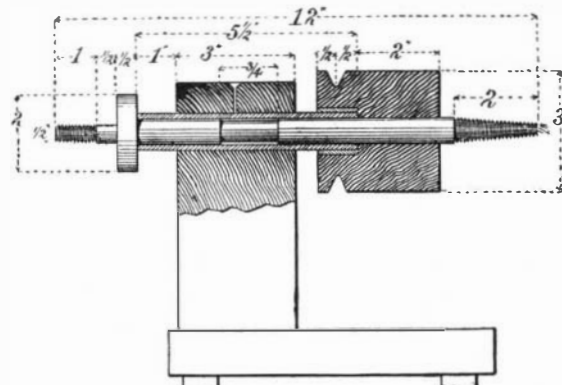

DIMENSIONS OF THE GRINDER HEAD.

vided, and these should each be drilled 16 inches from the bottom with a hole of a size to fit tightly on the nuts on the ends of the rear axle. These boards should be nailed to the floor on each side of the rear wheel, and nailed to a board at the top, so as to clamp the bicycle frame tightly between them, with the axle in the holes previously mentioned. This board should be firmly fastened to the top of the bench, and should be long enough to bring the grinding wheel in a convenient position, while its width should be sufficient to cover the tops of the axle supports. An upright board should support the head of the frame, so that the pedals will clear the floor by about 2 inches. The grinder head, used with this foot-power device, consists of a block of wood about 3 x 3 inches fastened firmly on to the top board by nails or screws, and of sufficient height to bring the grinding spindle to the desired position, a brass bushing which is of about ½-inch iron pipe size tightly fitted in a hole in the top of the block, a grinding spindle, and a grooved wood pulley. The spindle is the only piece requiring lathe work, and even this may be eliminated by using a straight rod (the bushing tube being of a size selected to fit it) and very carefully threading it with a ½-inch 12 die for the collar and clamping nut. It is, however, much more satisfactory to have a turned spindle, as it can then be made a better fit in the bushing, and the inner collar and part carrying the wheel can be turned true with this bearing surface. The part of the spindle that goes into the inner collar should be made a drive fit in the collar, and the latter should be turned while in place on the spindle. A nut and large washer should be provided for clamping the grinding wheel on the spindle. The other end of the spindle is formed with a threaded taper for polishing and buffing wheels, although it would be cheaper to leave it blank. It could also be arranged to carry a second grinding wheel if desired. The pulley which goes on this spin-



A SIMPLE FOOT-POWER GRINDER.

dle is cut (if possible turned) out of a piece of hard wood, and is bored so as to make a tight fit on spindle. If it should show any tendency to slip, a set screw can be run through it and against the spindle. This completes the machine with the exception of a ¾-inch leather belt, a grinding wheel (¾ x 6 inches is a good size) and, if desired, a tool rest which can be rigged up around the wheel.