

SCIENTIFIC AMERICAN

[Entered at the Post Office of New York, N. Y., as Second Class Matter. Copyright, 1908, by Munn & Co.]

Vol. XCIX.—No. 16.
ESTABLISHED 1845.

NEW YORK, OCTOBER 17, 1908.

[10 CENTS A COPY
\$3.00 A YEAR.]

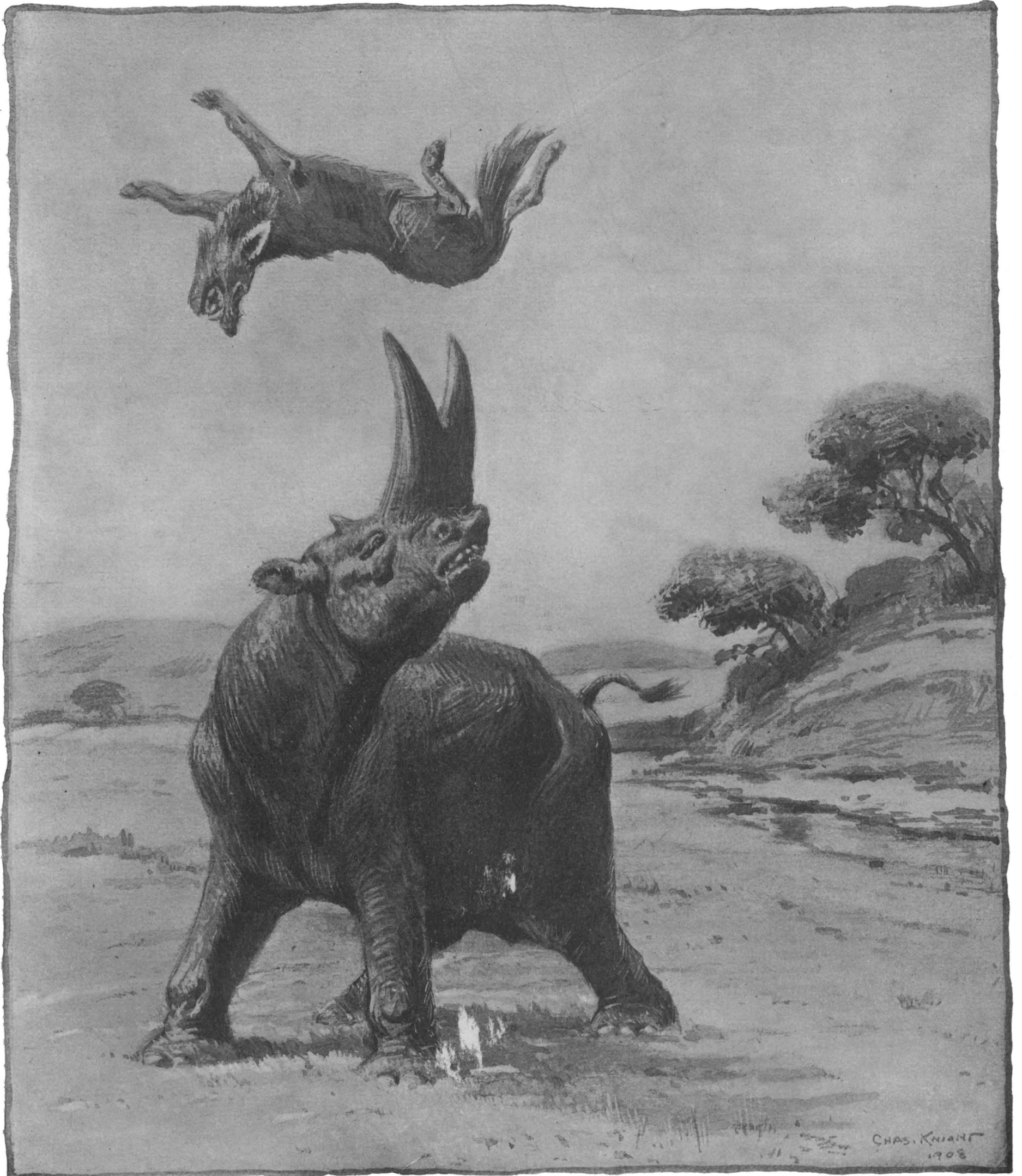

Copyright 1908 by Munn & Co.

Drawing by Charles R. Knight.

THE GIANT ARSINOITHERIUM, THE NEWLY DISCOVERED HORNED MONSTER OF PREHISTORIC EGYPT.

The first skull of this wonderful extinct beast has just reached New York at the Museum of Natural History.—[See page 261.]

SCIENTIFIC AMERICAN

ESTABLISHED 1845

MUNN & CO. Editors and Proprietors

Published Weekly at

No. 361 Broadway, New York

CHARLES ALLEN MUNN, President

361 Broadway, New York

FREDERICK CONVERSE BEACH, Sec'y and Treas.

361 Broadway, New York

TERMS TO SUBSCRIBERS.

One copy, one year, for the United States or Mexico \$3.00
 One copy, one year, for Canada 3.75
 One copy, one year, to any foreign country, postage prepaid, 18s. 6d. 4.50

THE SCIENTIFIC AMERICAN PUBLICATIONS.

Scientific American (established 1845)..... \$3.00 a year
 Scientific American Supplement (established 1876)..... 5.00 "
 American Homes and Gardens 3.00 "
 Scientific American Export Edition (established 1878)..... 3.00 "

The combined subscription rates and rates to foreign countries, including Canada, will be furnished upon application.

Remit by postal or express money order, or by bank draft or check.

MUNN & CO., 361 Broadway, New York.

NEW YORK, SATURDAY, OCTOBER 17, 1908.

The Editor is always glad to receive for examination illustrated articles on subjects of timely interest. If the photographs are sharp, the articles short, and the facts authentic, the contributions will receive special attention. Accepted articles will be paid for at regular space rates.

SOME THEORIES VERIFIED.

No sooner had the electrical service of the New Haven four-track road to Stamford been put in service, than it was evident that the application of the alternating current to this trunk line, burdened as it is with an unusually heavy traffic, had been made ahead of its time; that is to say, sufficient experimental work, on a full-sized scale, had not been done to provide the necessary data for a work of such vast importance. Troubles developed in the line, in the track, and in the motors, and the continuous breakdowns in operation were in sharp contrast with the smoothness with which the third-rail electrical equipment of the New York Central Road, based as it was upon the world's twenty years of experience in direct-current traction, had operated from the day on which electric service was opened. It required no little courage on the part of the New Haven Company to jeopardize the most important section of road on its whole system, by subjecting it to an experiment of this magnitude; and the greatest credit is due them for adopting at such an early stage what, in the opinion of the most advanced electrical engineers, is destined ultimately to become the universal system for the electric operation of long-distance trunk railroads.

But if the company failed to appreciate the importance of certain fundamental principles of a mechanical kind affecting the line, the track, and the motors, they are certainly to be congratulated upon the ingenious and very effective manner in which the weak points in the system have at last been met and mastered. The failures of the trolley line were due to the adoption, with a view to stiffness, of a three-fold, triangulated line, consisting of two steel cables to which the third or trolley wire was suspended by triangles, attached at every 10 or 12 feet of the length of the line. The system proved to be stiff enough, and the rigidity aimed at was fully secured; but it involved the disadvantage that the trolley wire was unyielding at its point of attachment to the triangles, and flexible between them. Consequently the pantograph contact-shoe, thrusting vertically against the wire with a pressure of from 25 to 40 pounds, struck a hard spot every time it passed a triangle, with the result that a serious hammering was set up at these points. This induced rapid wear and frequent breakages. The difficulty has been cleverly overcome, by hanging a second wire a couple of inches below the first, and attaching it to the former midway between its points of support on the triangles. The scheme appears to be working admirably and there is a marked absence of sparking and wear, the compensating effects of the present method of suspension appearing to give a wire of uniform flexibility.

The track and motor difficulties both arose from the heavy concentration of weight on a short wheel base which characterizes the motor. This induced an excessive amount of "nosing," or lateral oscillation of the motors, which, in turn, proved very destructive to the track, tending to spread the rails and destroy the alinement. It was to this cause that the derailment of the White Mountain Express a few months ago was generally attributed. The side sway of the motors has been completely eliminated by placing a pony truck at each end, with the load compensated with that on the nearest driver. In addition to thus lengthening the wheel base, an ingenious contrivance for

preventing the side movement of the body above the trucks has been introduced. It consists, in each case, of a rocker side-bearing, pivoted to the truck frame, and carrying the weight of the ends of the motor body upon a curved upper surface. This curve is struck, not from the pin upon which the rocker is pivoted, but from a point a little to the outside of the pin. The resulting action is that, if the body of the motor tends to move laterally above the truck, there is a pinching action on the side bearing tending to resist this motion exactly in proportion to its amount. The device has proved to be highly effective, the motors now riding with the steadiness of a Pullman car.

Contemporaneously with this change in the motors, the company has been laying the whole of the electric zone with four-spike tie-plates, with two plates to each tie. Furthermore, all the curvature of the road has been adjusted by adding to the superelevation of the outer rail, the effect of which is strikingly noticeable on certain curves which had become notorious among the patrons of the road for their rough riding. As far as the sensations of the passengers are concerned, that heavy jolting to the outside of the curve, which was perceptible at high speed before the elevation had been increased, has been entirely eliminated. With its line, motors, and track in such admirable order, there is nothing to prevent the New Haven Railroad Company from accelerating its service to compare with the fastest express service in Great Britain and on the Continent, where several trains are run on a schedule speed of 60 miles an hour.

LANGLEY—A TRIBUTE.

It is rarely that a great invention can be credited, from the genesis of the crude idea to the embodiment of that idea in the perfected mechanical form, to a single individual. In stamping such an invention with the name of one man as its author, we are in danger of doing injustice to many workers in the same field, whose labors have contributed more or less abundantly to the final result. The world, however, persists in giving the palm to some particular one among the many; and it has adopted the rough-and-ready method of naming inventions after the men who first succeeded in putting them into practical, working shape. Hence, we speak of Stephenson as the father of the locomotive; Fulton of the steamboat; Morse of the telegraph; Bessemer of steel; and Marconi of wireless telegraphy. Following this rule, the world will undoubtedly speak of the Wright brothers as the inventors of the man-carrying aeroplane, since they were the first to build a motor-driven flying machine, that carried a man for an extended flight. Without entering into a discussion of the merits of this system of award, the SCIENTIFIC AMERICAN is of the opinion that to the Wright brothers, more than any others, is due the honor of the premier position in this new sphere of locomotion.

Having said this much, however, we hasten to assert that there has never been a field of experiment in which the inventor was pressed so hard by the holder of second place—to which position the late richly-gifted and too-little-appreciated Prof. Langley of the Smithsonian Institution is undoubtedly entitled. To this proposition no one will give readier and more loyal assent than the Wright brothers themselves; for they would probably be the first to admit that, had it not been for the elaborate researches in aerodynamics of Prof. Langley, and the rich mine of information contained in his published work, "Experiments in Aerodynamics," their successful flights at Dayton, Kitty Hawk, Washington, and Paris might never have been made. Furthermore, it is the belief of those who are qualified by their knowledge of the history of the art and of the particular facts in this case to express an opinion, that, had it not been for an accident during launching, Prof. Langley's aerodrome would probably have been the first machine to fly with a man on board—this belief being based upon the uniform success attained by the successive models with which Langley experimented in the neighborhood of Washington.

It is rarely that the experimentalist embodies in himself both the theoretical and practical elements of success in such full measure as did Langley. Not only did he enunciate the principles of flight, but he illustrated those principles in mechanical forms that betrayed an unusual amount of technical skill. He was the first to formulate the laws of flight and explain them so clearly that an intelligent mechanic would be able to build a flying machine that could fly. Mr. Octave Chanute, one of the leading authorities on aviation, writing in 1896 of Langley's investigations, said: "In my judgment the principal contributions thus far made by Dr. Langley to the science of aerodynamics consist in his having given the physicist and searchers firm ground to stand upon concerning the fundamental and much-disputed question of air resistances and reaction. . . . Now, for the first time, searchers are enabled to calculate the sustaining power, the resistance, and the center of

pressure of a plane, with confidence that they are not far wrong." Previous to Langley's researches, it was believed that the resistance to a flying machine would increase in some multiple ratio of the speed, and that, because of the excessive power required, and the consequent increase of weight, flight at any high speed would be inherently impossible; but Langley's investigations led him to formulate that most important law, that within certain limits the higher speeds are more economical of power than the lower ones. In other words, he proved that at high speeds the planes would pass over the successive areas of air so rapidly that there would not be time for its inertia to be overcome, the conditions being approximately similar to those of a skater passing swiftly over a thin layer of ice.

Langley's earliest interest in the subject of mechanical flight dates from the period, over a quarter of a century ago, when he was director of the Allegheny Observatory. At that time he was attracted by the studies of Lanchester, in which he set forth the results of his study of the flight of birds; and following the example of that investigator, he made a study of the resistance and supporting power of various plane surfaces, by mounting them upon a rotating table. The results of these experiments were published in the work upon aerodynamics to which we have referred above.

Having formulated the laws of mechanical flight, Langley set about the construction of a flying machine; and he was at once confronted with the disconcerting fact that there was no motor available of anything approaching the light weight per horse-power that was necessary to drive his machine. Nothing daunted, and in spite of the fact that he was not an engineer by training, he designed and made, largely with his own hands, a steam engine and boiler which weighed only about four pounds per horse-power, a feat which, in itself, marked him as a man of uncommon mechanical ingenuity. He succeeded in making this model fly for a distance of over half a mile above the waters of the Potomac, this being the first flight accomplished by a motor-driven machine. Ultimately Congress granted him an appropriation of \$50,000 for the prosecution of his work; and with this backing and the help of his talented assistant, Mr. Manly, he built his celebrated aerodrome. His failure to continue his experiments was due solely to the exhaustion of his own and the government funds; and was not in any sense a confession of failure. But it was taken as such by a certain section of the press. Undoubtedly the outrageous criticism and ridicule to which he was subjected, on the very eve of success, contributed largely to his premature death.

WANTED: A SANITARY RAILWAY CAR.

One of the papers read before the Tuberculosis Congress at Washington dealt with the subject of the unsanitary railway car. Since the improvements suggested by the writer of the paper deserve the consideration of the inventor, we present the following abstract of his remarks:

The points that need attention in a Pullman car are the bedding, the ventilation of the berth when made up, the use of the wash basin for teeth-cleaning, the use of common drinking glasses, etc. Theoretically, the danger from the blankets has been diminished by the use of a third sheet as a counterpane, but practically this third sheet is of little if any protective value. The sleeping berth is generally made up with two blankets for covers. This is too much for the ordinary sleeper at all times, and the result is that one or both blankets are thrown back. To throw off one or both blankets necessitates the throwing back of the third or upper sheet. Thereupon it ceases to afford any protection for the blankets. A long upper sheet to turn back over the blankets at the top is far better than the third sheet. This is a matter more for the porter than the inventor to consider.

The lack of ventilation in the lower berth when made up is simply beyond description. This can and should be corrected, and here the inventor can do much. It will undoubtedly mean a change in car construction, but this can and should be met from this time on in all new cars.

Arrangements should be made so that it might be possible to clean one's teeth without spitting into the basins provided for lavatory purposes. Here again the inventor can help.

According to the Far Eastern Review, a Chinese gentleman named Hu Chuen has obtained a patent on an improved method of wireless telegraphy, simplifying the methods hitherto in use. The system has been recommended by Chinese authorities for the reason that it makes use only of domestic Chinese materials of lower cost than imported articles, and it is also simpler to operate. At the test of the equipment at Canton it was pronounced a success. Detailed information as to the workings of the new system, however, are not as yet at hand.

ENGINEERING.

The figures of coke production in the United States in 1907 exceed all records in the history of coke making in this country, the total amount reaching 40,779,564 net tons. Over 35,000,000 tons of this total was produced in the beehive type of oven.

A dozen bids have been received at Albany by the State Barge Canal Board for the construction of a reservoir dam at Delta, at the head waters of the Mohawk River, the lowest tender being that of Arthur McMullin, of New York city, whose bid was \$905,347. This is more than \$107,000 under the engineer's estimate.

The total value of our pig-iron production in 1907, estimated at \$20.59 per ton, was \$529,958,000; but the journals devoted to the iron and steel trade estimate that because of the financial depression, the rate of production will prove to have been reduced nearly 50 per cent during the present year—unless, indeed, the present signs of recovery are fulfilled.

The Pennsylvania Railroad has awarded prizes to the amount of \$5,400 to the supervisors and their assistants who maintained the best stretch of track during the last year. The tracks were inspected from a special train. One of the tests was to place glasses of water on the sills of the windows, and count the number of times they were spilled in running over a stretch of track.

The general public will learn with some surprise that of the total freight moved on all railroads during 1904, amounting to 641,680,547 tons, only 4,809,340 tons represented petroleum and all other oils; and that the total amount of petroleum shipped by the Standard Oil Company amounted to 2,887,500 tons, or less than one-half of one per cent of the total tonnage moved on all railroads during the year.

The report of the chairman of the Isthmian Canal Commission for August states that the reorganization of the forces was continued during the month. The summary of the construction work done by the three divisions shows that the material excavated in August amounted to 3,318,691 cubic yards, of which 1,375,991 yards were taken from the canal prism. The average number of laborers employed daily was 13,284. Health conditions continued satisfactory during the month.

Results obtained in several tests of the Maxim silent firearm before the United States Army Board are reported to have been decidedly encouraging, the report of the explosion being only faintly audible. The muffling of the discharge is necessarily obtained at some expense of velocity, though the reduction is said to be only about six per cent. If the loss of velocity and energy be no greater than this, the silencing of the report unquestionably increases the military value of the weapon.

In spite of the worldwide depression, Spain is experiencing a period of decided prosperity. The spirit of rejuvenation has extended to the navy, plans for the rebuilding of which are being actively prosecuted. Tenders have been submitted for three battleships, which will be about 425 feet in length and of 15,000 tons displacement, with a speed of 19½ knots. Also three destroyers of 360 tons and 28 knots and twenty-four 180-ton 26-knot torpedo boats are to be built, together with four gunboats of about 1,000 tons displacement. The battleships will be built at Ferrol, and the rest of the fleet at Carthagena.

At the last meeting of the Iron and Steel Institute in Great Britain, Henry E. Armstrong, professor of chemistry of the London Central Institute, said that he found it "difficult to keep calm" when he reflected on the ruthless way in which the world's stores of timber, iron, coal, and oil were being used up. The public, satisfied that science would discover a substitute for coal, was seemingly indifferent to the inevitable consequence of the present lavish waste. Science, however, is in no position, at present, to confidently state that any substitute for these fuels will be available in that near future when our present supplies will be exhausted.

That the Japanese are not always the mere imitators which some people would have us believe, is shown by the decidedly original method they have adopted for carrying two submarines from England to Japan. The "Transporter," a ship specially designed for this purpose, has been built by Messrs. Vickers, Sons & Maxim for carrying submarines intact. The engines are located aft, and forward of them the main deck for two-thirds its length has been removed. To place the submarines on board, they are floated into the drydock alongside the "Transporter." The latter is sunk to the bottom of the dock, and the submarines are then floated into position above a pair of cradles built into the hull of the ship. The water is then pumped from the dock, and, as it subsides, the submarines settle into their respective positions in the hold of the steamer. The main deck is then replaced, and the ship is pumped out until she is afloat.

ELECTRICITY.

Electric flatirons are becoming very popular in central Vermont, owing to the enterprising advertising of the Consolidated Lighting Company, which serves the district of Montpelier and Barré. There are 28,000 inhabitants in this district, and one out of every twenty-seven uses an electric flatiron.

In an address delivered before the Electrical Club of Chicago on the subject of the electrification of steam railroads, F. A. Sager stated that the railroads will have to spend approximately \$5,000,000,000 within a few years to keep up with the increase of traffic. By electrifying their lines at a cost of \$4,000,000,000, they would increase their capacity to such an extent that no new trackage would be needed.

A successful test of wireless telephony was recently conducted between the British cruiser "Furious" and the schoolship "Vernon." Both vessels were steaming at full speed, separated by a distance of 50 nautical miles. The De Forest system was used. The inventor operated the transmitter on the "Furious," while Mrs. De Forest received the messages on the "Vernon." The test consisted largely in repeating stock quotations and it is stated that out of 154 figures, there were only two mistakes.

In a recent article by Dr. Louis Bell in the Electrical World, attention is called to the lighting systems of Europe as compared with American street lighting. According to Dr. Bell, European streets are far better lighted than our own, but not because electricity is cheaper abroad than here; for London pays over \$100 per arc per year, Paris \$166, and Berlin nearly \$120. The difference seems to be that in this country we attempt to light all of the streets fairly well, while abroad particular attention is paid to the more prominent streets.

The highest telephone line in Europe, which runs to the Regina Margherita Meteorological Observatory on Mont Rosa, at an altitude of 14,958 feet, is nearing completion. It was found impossible to run this line on poles, owing to the high winds and bad storms which prevail at these altitudes. It was also thought to be impracticable to lay an insulated cable, as it would gradually sink into the ice and would make repairs impossible. The final solution of the problem was to lay a bare wire across the glaciers, and depend upon the insulating qualities of the snow and ice.

Writing in the Electrical Review, Mr. G. W. Pickard describes some interesting experiments made to determine the character of wireless wave fronts. A closed circuit is used for the receiving system; that is, the antenna instead of being a vertical wire, is in the form of a hoop. The receiving apparatus is mounted on a tripod, so that it can readily be moved from place to place, and rotated to turn the hoop to any desired angle. When the plane of the hoop lies at right angles to the direction of the wave, the maximum number of electro-magnetic lines of force pass through it. In this way the wave front can be plotted out, and the disturbing effect of various obstacles can be determined.

The Forestry Bureau of the United States has recently been investigating the preservation of cross arms for telegraph and telephone wires. The trouble heretofore has been that the wood subjected to the creosote process has not been of uniform porosity, some of the arms absorbing more of the preservative than was necessary, while others did not receive sufficient treatment. The Forestry Bureau divides the wood into three grades according to grain and air-dries them thoroughly in piles protected from rain and snow. The different grades are separately treated, receiving from 6 pounds to 10 pounds per cubic foot. It is advised that the wood be not subjected to the customary steam-bath before being treated with creosote.

Several years ago Prof. A. Heydweiller observed the remarkable phenomenon of self-electrification of the human body. The needle of a quadrant electrometer having been charged to a potential of some hundreds of volts, one of the pairs of quadrants was connected to the earth, and the other to an insulated metal plate. The subject then raised one of his hands to about 4 inches from the plate, and holding it in this position stepped on an insulating stool, when the electrometer showed a deflection indicative of a negative charge of the hand. The magnitude of this deflection and the interval of time occupied by its slow disappearance would vary according to the personal disposition of the subject and meteorological conditions. The same problem has been taken up recently by two Russian physicists, Drs. Tereshine and A. Georgievski. Whereas the qualitative results of the first series are mainly identical with those of Prof. Heydweiller, the electric tensions (of 10 to 15 volts) found by the Russian experimenters are much inferior, and experiments made on naked subjects gave very different results. And hence they draw the conclusion that the self-electrification of the human body is due, not to the contraction of the muscles, but to the friction of the feet on the insulating stool and to that of the clothes on the body and on one another.

SCIENCE.

On October 5 the first international congress on refrigeration was opened in Paris, thirty governments in all being represented. The United States, which leads the world in the production of cold-preserved foodstuffs, together with the republics of South America, took an important part in the proceedings. Some idea of the extent of the refrigerating business of the world is furnished by the committee of arrangements, which points out that a fleet of more than three hundred ships fitted with cold storage plants is now engaged in the transport of refrigerated products to Great Britain alone. The British cold storage imports have risen from \$17,000,000 in 1885 to \$180,000,000 in 1907. The United States, however, exceeds that figure, her cold storage commerce being valued at about \$240,000,000.

In an oil refinery at Langelsheim, Germany, linseed oil is bleached by a process in which uviole lamps are employed, and which has been patented by Dr. A. Centhe. The uviole lamp, which has been described in these columns, is a mercury vapor lamp which produces ultraviolet rays in abundance, and is made by a special glass which transmits waves as short as 253 millionths of a millimeter. Twenty uviole lamps are immersed in a tank containing one ton of crude linseed oil, heated to 176 deg. F., into which air is simultaneously introduced in fine bubbles. Under the influence of the ultraviolet rays the oil absorbs 1/20 of its weight of oxygen and becomes colorless, brilliant and limpid. The expenditure of energy is 60 kilowatt hours per ton of oil. The air is forced through the oil by a pressure equivalent to 10 feet of water.

Dr. Leonard Hill's experiments in reviving exhausted athletes with oxygen may soon be made the subject of investigation by international athletic associations. Thanks to the administration of oxygen, Jabez Wolffe nearly succeeded in equaling Capt. Webb's famous feat of swimming the English Channel from Dover to Calais in 21 hours and 45 minutes. One of Wolffe's rivals denounced the practice, arguing that it was unsportsmanlike. To this Dr. Hill gives the retort scientific: "Oxygen is not a stimulant. To the perfectly trained runner or race horse oxygen will do nothing if given before a sprint. The trained man or horse has got enough in him for a sprint, and an excess has no effect. It is to the tired or untrained man or to the man fatigued by prolonged effort that oxygen does so much. Oxygen will not make a man do something that is beyond the power of the normally working heart and muscles. It will do neither more nor less than the food taken in long-distance swims. Beef juice is food, and oxygen is food. One is liquid and must be drunk; the other is gas and must be breathed. It is foolishness to give one and not the other. Almost the whole of modern sport is conducted with artificial aids. The record feats of to-day are too often not sport, but deadly, earnest business." Dr. Hill sensibly suggests that either sport should be limited to reasonable feats of endurance or else oxygen should be added to the other artificial aids now employed in breaking records, and so diminish the harm done the athlete's body.

The place occupied by the Milky Way in the theory of the universe is continually increasing in importance. This vast belt of stars is now regarded, not as a cluster comparable with thousands of other clusters, but rather as the frame or skeleton of the entire stellar universe. Additional support for this view is derived from H. H. Turner's comparative study of variable stars of long period. Our sun is, to some extent, a variable star. The variations in its luminosity complete their cycle in a period of about eleven years, during which the number of sun spots gradually increases from zero to a maximum and then decreases until the solar disk is again entirely spotless. The solar activity is manifested periodically by the spots and also by the intensely luminous faculae which appear near the poles of the sun, move toward the equator, and there vanish. It is evident that the curve which represents the apparent variable luminosity of the sun will vary according to the position of the observer with respect to the solar axis, owing to the effects of perspective and absorption by the solar atmosphere upon the apparent brightness of the equatorial faculae. Several astronomers have expressed the opinion that the fluctuations of variable stars (with the exception of stars of the Algol type, in which the variations are due to eclipses by a dark satellite) are similar in character to those of the sun, though very different in degree. Turner, working on this hypothesis, has examined the curves of variation of a number of variable stars. He finds that some of these stars appear to present their poles, others their equators, to the earth, but that no stars of the former class are situated near the poles of the Milky Way. The natural inference is that the axes of rotation of all these variable stars lie nearly in the plane of the Milky Way.

THE EYES OF PLANTS.

In our issue of September 12 we published an article by Dr. D. T. Macdougall, director of the Department of Botanical Research of the Carnegie Institution, in which he showed that plants are so sensitive to light, that we may well raise the question whether they do not actually see. He showed that if response to light stimulation by appropriate movements is equivalent to seeing, then plants certainly see. Even if nothing short of the formation and apprehension of a definite range of external objects may properly be designated as sight, the plant world may not be regarded as totally blind. While Dr. Macdougall's article was on the press, Mr. Harold Wager was reading a paper before the British Association for the Advancement of Science, in which were described experiments he and other biologists had conducted for the purpose of showing how much a plant really can see.

He exhibited photographs taken through the epidermal cells of the leaves of plants. The upper and lower surfaces of leaves are covered by a thin transparent skin, which can, in many cases, be very easily peeled off. When examined under the microscope, as Dr. Macdougall showed in his article and as Mr. Wager reiterates, this skin is seen to consist of innumerable compartments or cells, many thousands of which are found on a single leaf. They contain a clear watery sap, and their shape is such that they behave like ordinary convex or plano-convex lenses, the rays of light which fall upon them being converged and brought to a focus in the substance of the leaf. According to Prof. Haberlandt, a German botanist, these cells enable the plant to perceive the difference between light and dark, and set up a stimulus which results in the movement of the leaf into such a position that it can obtain the maximum amount of light; or it may be, as Mr. Wager is inclined to think, that these cells serve for the more efficient illumination of the green grains within the leaf upon which the effective food-supply of the plant depends. Possibly both play some part in aiding the leaf to perform its work more efficiently. These cells are found in practically all plants; but are most clearly seen in some shade plants. Prof. Haberlandt was able in one case to photograph a faint image of a microscope through the cells, and Mr. Wager has more recently obtained photographs of various objects some of which are here reproduced. In many cases these lens-cells may be compared with the corneal facets of an insect's eye, so far as their general appearance and power of causing a convergence of light are concerned. In addition to ordinary methods of photography, it has been found possible to obtain photographs of simple patterns in colors by means of the autochrome plates of Messrs. Lumière. In taking these photographs, whether in the ordinary way or in colors, the images formed by the leaf cells are magnified by the microscope from 100 to 400 or more diameters, and the photographs are obtained by an ordinary photo-micrographic apparatus; but the best results have been obtained with the Gordon photo-micrographic apparatus. It is not suggested that the plant can perceive the images which are thus photographed, but the fact that such images can be formed shows that these cells are very efficient lenses, and by means of them the plant may be enabled to take more advantage of the light which falls upon it than it would otherwise be able to do.

Waste Wood and Veneer.

Five hundred manufacturers of explosives, pulp wood, and similar products, have been asked by the National Conservation Commission for information as to all possible uses of sawdust. From this it will be seen the Commission is going into fine details in its inventory of the natural resources of the country. Seven thousand lumbermen have been asked for their

opinion as to the waste of lumber in sawmills, and more than two thousand lumber dealers and cooperage, veneer, furniture, box, vehicle, and implement manufacturers have been asked to point out striking

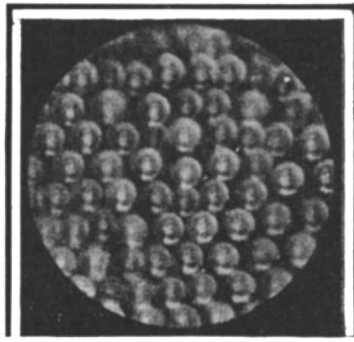

A much reduced copy of a portrait taken through epidermis cells.

features of waste in their respective lines. Yet all this is only one part of the general scheme of hunting down waste which the Commission is following in making its inventory. It is going after the little

course, has been made possible only by the introduction of new veneer-making machinery.

The use of veneer is generally regarded as exemplifying the scarcity of the finer woods and typifying the complete utilization of various kinds of woods, yet from one of the schedules of the National Conservation Commission it is evident that the Commission expects to discover great waste even in veneer manufacture.

Though the word veneer carries many meanings, from a glaze applied to pottery to the "polish" of a man of the world, it is most commonly employed as the name for the thin slices of wood now extensively used in the manufacture of all sorts of articles of use, such as wood plates, baskets, and the exterior finish of furniture and wood work. The manufacture of veneer in the last few years has advanced by leaps and bounds.

The best veneer is sawed, but a great deal is sliced and still more is "rotary cut." By the last named process logs of the desired wood are steamed until they are soft and then fixed in a lathe-like machine, in which they are turned against a wood knife. As the log rotates against the knife, veneer of the desired thickness is peeled off in a continuous slice, as if you should pare an apple, going deeper and deeper at each complete turn, until nothing is left but the core. The center of the log left after the veneer is cut is also called a "core."

The woods principally used for making veneer are red gum, maple, and yellow poplar, which together yield more than half of the total product. Red gum is largely used for baskets and maple for furniture. More valuable than these, however, are white oak and walnut veneer. Beech, which can be cut very thin, is used very largely for wooden plates. A number of other kinds of woods are used.

A good deal of waste occurs in the manufacture of veneer. It is always a problem, for instance, what use to make of the cores left by the rotary process. In many cases these are used for pulp wood, pillars, or panel headings, and they are largely used also for fuel, excelsior, crates, boxes, and baskets.

In the schedule of inquiries which the National Conservation Commission, through the Forest Service, is sending out, several questions are aimed to secure information as to the amount of waste in veneer manufacture and the possibilities of finding ways to utilize it.

Microscopic Tests of Wood.

A new line of work, consisting of the microscopic examination of wood after it breaks in a testing apparatus, has been started by the office of wood utilization in the United States Forest Service. The structure of wood is complex. Every species has several different kinds of cells, each of which has its own size and form. There is also a wide variation in the number and arrangement of the cells in different species. These differences in structure have their bearing on the strength of the wood. For some time past the Forest Service has been carrying on a large number of tests on many kinds of wood in order to determine their strength, stiffness, elasticity, and other physical properties. It is not expected that laymen will understand the significance of the proposed microscopic investigations as quickly as architects, builders, and other wood users.

The average life of an automobile does not exceed five years, according to the published statistics of automobilism in France. In January, 1903, there were in France 12,984 recorded automobiles. During the year 1903, 6,900 new cars of French make were sold, and 350 automobiles were imported. Hence there should have been 20,234 automobiles in France at the end of the year, but the number recorded in January, 1904, was only 17,107. From these figures and those of the following years it has been computed that the average life of an automobile is 4.99 years.

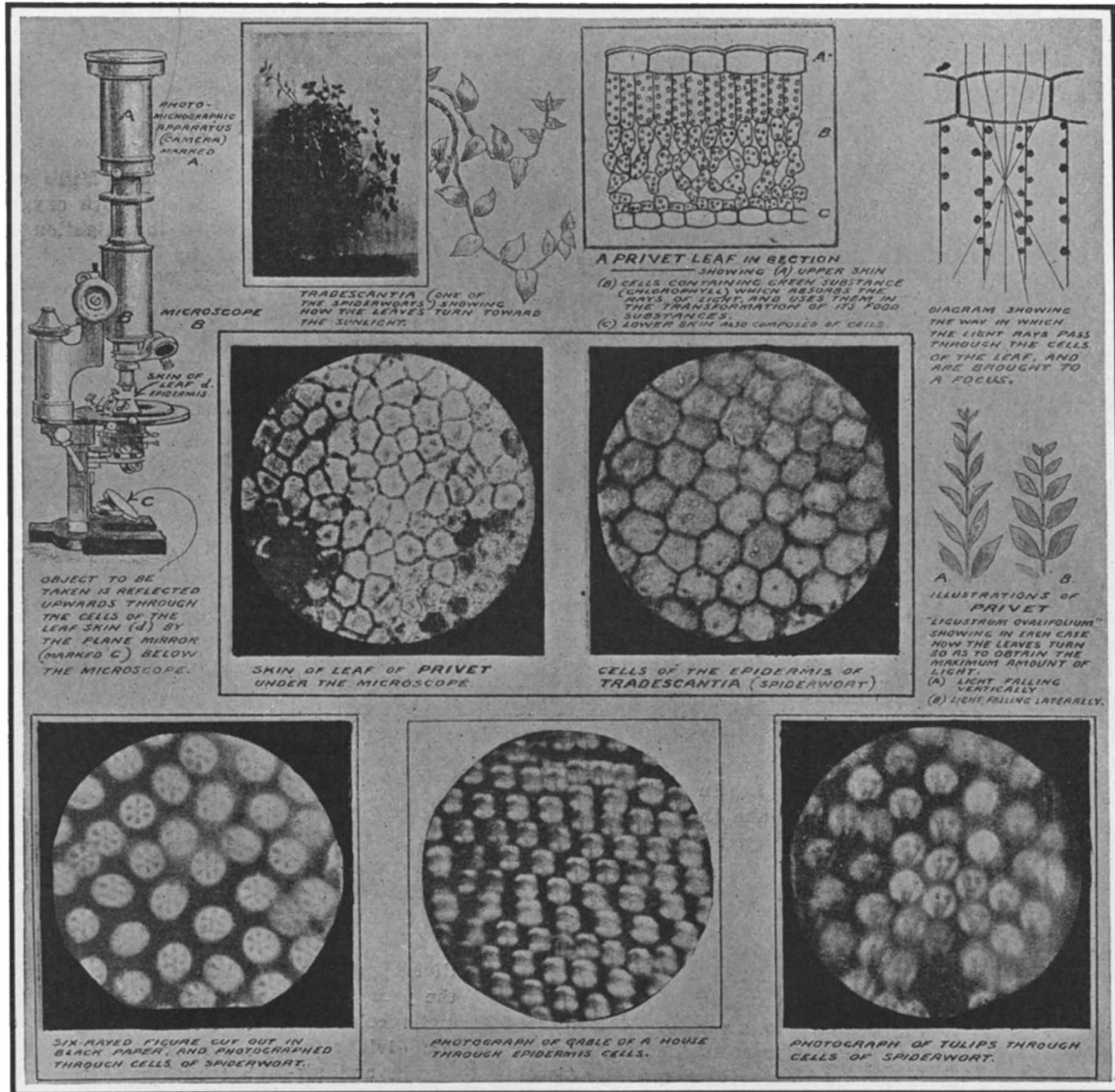

By courtesy of Illustrated London News.

Drawn by Will B. Robinson from material supplied by Harold Wager, F.R.S.

THE EYES OF THE PLANT: THE LENSES OF THE LEAF.

wastes here and there, which, added together, and put into dollars and cents, make an astonishing total.

For instance, take the making of veneer. At first blush it may not seem worthy of consideration with

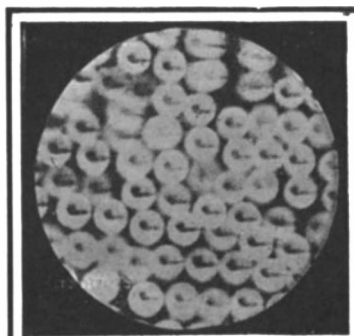

Photograph of a pipe through the cells of spiderwort. A beetle would see the pipe in this way.

the manufacture of other products mentioned. Yet, the scarcity of the more attractive finishing woods in the last few years has led to the annual production of over 1,100,000,000 square feet of veneer. This, of

A NEW ICE-MAKING MACHINE FOR DOMESTIC USE.

Nearly all ice-making machines depend for their operation upon the property of certain substances to absorb a large amount of heat when changing from the liquid to the gaseous state. As a rule, anhydrous ammonia is the substance used, and this is forced through a closed cycle consisting of a compression chamber and an expansion chamber. In the latter chamber the ammonia expands into a gas, absorbing heat as it vaporizes. Then it is drawn into the compression chamber by a pump and compressed into a liquid, only to flow back into the expansion chamber and expand into a gas. Thus one chamber of the machine is made cold by the vaporizing ammonia, while the other develops heat because of the compressing of the gas. The heat from the compression chamber is dissipated by a suitable radiator system, while the influence of the expansion chamber can be extended at will by a system of pipes through which brine is circulated.

The difficulty with refrigerating machines as commonly constructed is that long stuffing boxes are necessary to prevent leakage of the ammonia, and the friction developed in these stuffing boxes not only absorbs energy, but generates additional heat. The smaller the machine, the more serious are these

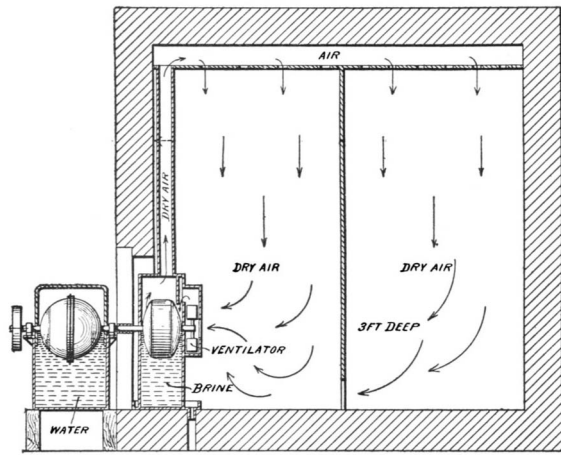

The machine as used with a refrigerator box.

losses, because of the pressure that must be maintained, which does not permit the friction to diminish in proportion to the capacity of the machine. For this reason, refrigerating machines for domestic use have not been as economical as those of large plants.

Recently a machine has been invented by Prof. Audiffren, of Paris, based on the same principle as the ordinary ice machine, but so designed as to do away with all stuffing boxes, pressure gages, agitators, valves, or anything that would require the attention of an operator. As shown in the accompanying sectional view, it consists of two chambers or drums, which are connected by a hollow shaft. A solid extension of this shaft passes through the larger chamber, and at its outer end carries a pulley, which provides means for operating the machine. The shaft is sealed into the chambers, so that as the pulley revolves, the chambers revolve as well. Mounted to swing freely on the shaft within the larger drum is a small pump, which is kept vertical by means of a lead weight (of about 70 pounds in the machine illustrated) attached to its lower end. The piston of this pump is connected to a crank offset in the shaft, so that when the pulley is rotated, the shaft revolving with it will operate the piston, the latter being kept vertical by its connection with the weighted compressor. In the smaller machines the drums are charged with anhydrous sulphurous acid instead of ammonia.

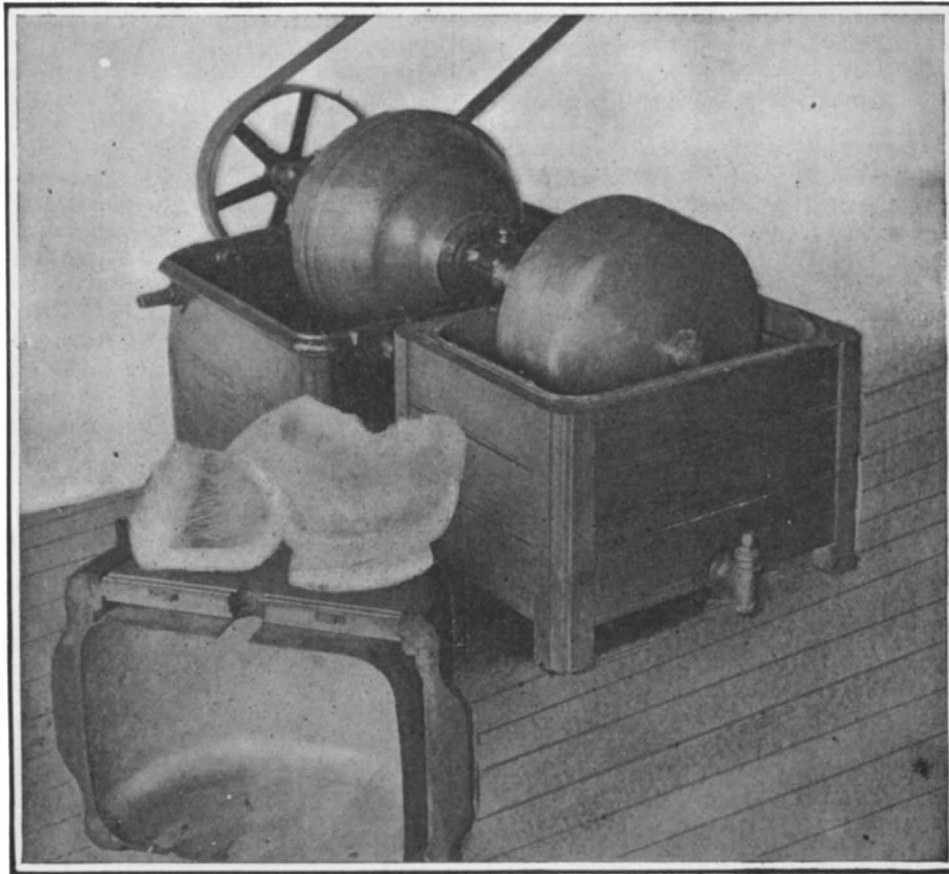

The water tank casing removed to show the two drums. In the foreground is some ice taken from the refrigerating drum.

The pump serves to draw the gas from the smaller or expansion drum through the tubular shaft, compress it into a liquid, and discharge it into the larger or compression drum, whence it flows back through a pipe leading through the tubular shaft into the expansion drum. Here the liquid evaporates, and is returned to compression chamber by the action of the pump. It will be seen that the entire operation is a closed cycle, the drums are hermetically sealed, and there is no possibility for the liquid or gas to escape. Owing to the fact that stuffing boxes are eliminated, friction is reduced to a minimum, and about two-thirds of the power used by other machines of the same size is saved. In order to provide sufficient lubrication, the pump is kept swimming in oil. The pump is fitted with a reservoir capable of carrying half a gallon of oil. The oil cannot escape, and such of it as leaks out of the pump is trapped and returned to the reservoir. Owing to the rapid rotation of the drum, the liquid acid is centrifugally thrown against the inner periphery of the chamber, and any oil that leaks into the chamber is centrifugally separated from the heavier sulphurous acid, forming an annular layer within the acid layer. Our

illustration shows the acid and oil in section at the bottom and top of the compressor chamber. At the top of the oil reservoir is a scoop, which extends upward sufficiently to dip into the oil, but without reaching the layer of sulphurous acid. This scoop collects the oil, causing it to fall back into the reservoir.

The machine requires no pressure gages, for the reason that if it heats too much, and the pressures becomes too great, the entire compressor pump will rotate around with the shaft and do no pumping. In other words, the lead weight serves as a safety appliance to control the action of the machine.

Any form of power may be used to drive the machine. Some of the smallest ones are fitted with a crank, so that they can be operated by hand. The accompanying photographs show some of the uses of this novel machine. The compression chamber is half submerged in a tank of water, which absorbs the heat produced in this chamber. The expansion chamber or refrigerating drum may be used in various ways. One of the illustrations shows the machine after it has been run for a few minutes in the open air with no liquid around it. The chamber is covered

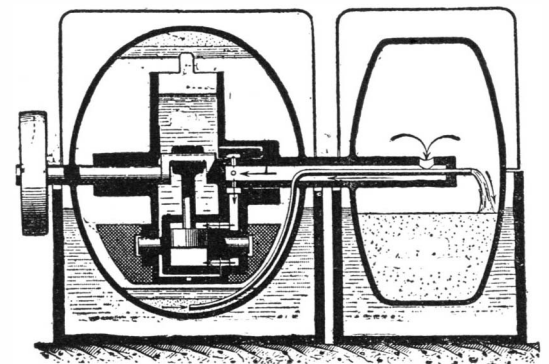

The mechanism inside the drums.

with frost, which is merely the condensed and frozen moisture of the atmosphere, which has collected on the drum. The drum may be rotated in a small tank, in which a small amount of water is placed, and in a few minutes the water will form a layer of ice over the drum. One of the photographs shows the ice-coated drum, while in another view are shown the pieces of ice which have been cracked off the drum. The tank in which the drum rotates is provided with a false bottom in which milk, wines, or any liquid that it is desired to refrigerate may be placed. After running the machine for a few minutes, the refrigerated liquid may be tapped off through the faucet shown in the foreground.

For the purpose of making ice for use in refrigerator boxes, a larger tank is provided. This tank is filled with brine, and is fitted with a number of metal containers in which slabs of ice are formed. Two of these containers are shown in the foreground of one of the illustrations. As the drum revolves, it agitates the brine and circulates it about the metal containers. The water with which these containers are filled is cooled and eventually frozen by the circulating brine, which abstracts the heat and conducts it to the revolving drum. The machine illustrated in the engraving is operated by a one-third horse-power motor, and will freeze forty-eight pounds of ice in four hours. As the heat in the tanks surrounding the compressor drum is apt to rise to a high degree, it is preferable to provide a flow of water through the tank. Where running water is not available, a ventilator is furnished, consisting of a fan attached to the motor, which drives air into the tank and around the

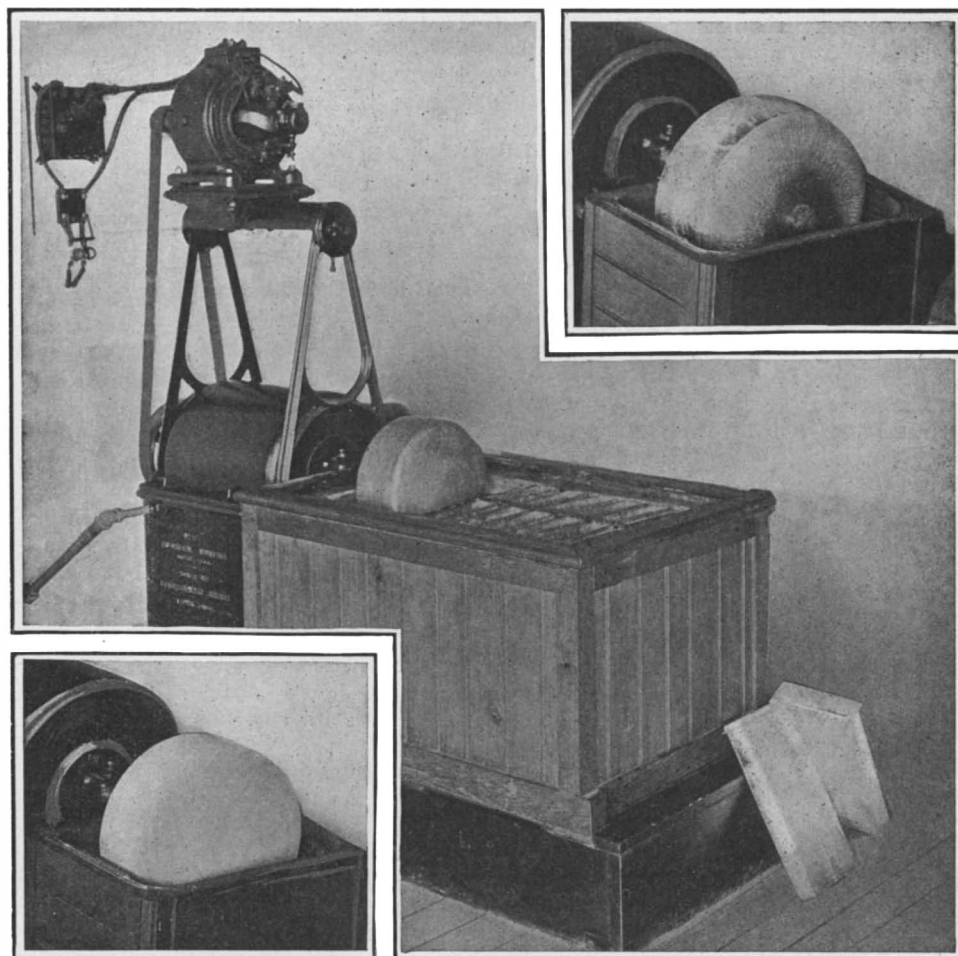

Making frost.

Coating the drum with ice.

The ice-making machine and the brine tank in which slabs of ice are formed.

compressor drum, so as to carry off part of the heat.

Ice cream can be made very quickly by suspending a can with the prepared cream in the tank of brine. The circulating brine will agitate the can sufficiently, so that the cream will be formed without turning any crank.

This form of machine is particularly useful for refrigeration purposes, as the refrigerating drum may be placed within the refrigerator box, and will directly absorb the heat of articles placed in the box without requiring the use of ice. The accompanying diagram illustrates one method of accomplishing this result. The refrigerator box is provided with a compartment at one end, in which the refrigerator drum rotates. A fan serves to draw the air out of the box, bringing it into contact with the refrigerator drum, and forcing it up a chimney to the top of the refrigerator box. Here the cold air is free to fall by gravity, or is sucked down by the fan through the box, absorbing the heat from the various meats and groceries placed therein. The particular advantage of this arrangement is that the air in the box is kept perfectly dry; for the moisture is condensed on the drum and drips into a tank of brine below, whence it may be tapped off when desired.

The Electrical Show at Madison Square Garden.

Fifty years ago the first cable message was flashed across the Atlantic. Twenty-five years ago the first bill for electric current metered in New York city was collected by the original Edison Company. These two events are commemorated in the Electrical Show now running at Madison Square Garden; and in honor of the occasion, Thomas A. Edison, who started the first electrical plant in New York at Pearl Street, generating current for four hundred 16-candle power lamps, has been elected president of this exhibition. In honor of the fiftieth anniversary of the submarine cable, a collection of oil paintings, water colors, electrotypes of gold medals, specimens of the original Atlantic cable, and various devices illustrating the method of laying the cable, has been loaned by the Metropolitan Museum of Art.

The features which attract the greatest popular interest are the incubator, cow milker, and the vacuum horse groomer. The incubator, which is heated electrically, contains eggs that are about ready to hatch, and a large number of chicks have made their entrance into the world before the very eyes of the spectators. The cow milker is exhibited on the floor below, where several patient cows are stalled. At milking time vacuum milkers are attached to the cows, and operated electrically. The horse groomer, which is also on this floor, is similar to a vacuum cleaner, the suction being produced by electric power.

The progress of wireless telegraphy is exemplified by the news bulletins which are published from time to time, the news being received by wireless telegraphy from the Times Building, set up on a linotype machine, and printed before the spectators. The efficiency of this system was illustrated by the printing of the score by innings of the recent New York-Chicago baseball game.

As in previous years, the Brooklyn Edison Company deserves special credit for its display. This year it has three sections, illustrating domestic, commercial, and industrial uses of electricity. The domestic appliances, particularly labor-saving devices for use in the kitchen, are very popular. The commercial section consists of a complete "gents' furnishing store," and shows the best method of lighting the store. The New York Edison Company, in commemoration of its twenty-fifth anniversary, occupies a large section of the floor in the form of tearooms, which are most artistically decorated and lighted. The rooms are fitted with electrical appliances of every sort for use in the household.

In one part of the building an underground man-hole in section shows the form of these large rooms under the sidewalk, where cables, telephone wires and the like are connected and spliced. The use of the photometer for measuring the total spherical candle-power of arc lamps and incandescent lamps makes a prominent part of the show. One of the tests shows how the efficiency of insulators for high-tension lines is determined. The insulators are subjected to a current under tension of 250,000 volts, in an artificial rainstorm. The play of lights around the insulators makes a beautiful and attractive exhibition, even for those who do not appreciate the value of the test.

Among the other exhibitions may be mentioned a new rectifier for alternating currents, in which no inductance, resistance, electrolyte, or vacuum tube is used. The current is mechanically transformed into an intermittent direct current, and may be used for charging batteries of one cell, or any number within the limits of the line voltage. A new method of repairing iron trolley poles is illustrated in one of the booths. It consists of a bundle of rods, which are lowered into the pole after the top cap has been removed. These rods are lodged in the pole at the proper depth to extend three feet above and below

the ground surface. At the upper end the rods spread out like ribs of a partly opened umbrella. Concrete is pumped into the pole until it covers the top of the rods. When the concrete sets, it renders the pole even stronger than in its original condition. Even if the iron should rust through, completely separating the upper part of the pole from the ground section, the reinforced concrete core would be more than able to stand all the strains that are imposed upon the pole.

The usual variety of domestic appliances are shown in great numbers, and the vacuum cleaner, of which there are several varieties exhibited, forms a prominent part of the exhibition. Altogether, the Electrical Show this year is well worth seeing, and an improvement upon last year's exhibition.

Wilbur Wright Fulfills the Conditions of His Contract with the French Syndicate.

After winning the \$1,000 prize offered by the Aviation Committee of the Aero Club of France for the longest flight up to October 1, by his flight of 48.1 kilometers (30 miles), recorded in our last issue, Mr. Wilbur Wright set out to fulfill the conditions of his contract with the French syndicate headed by M. Weiller, which required him to make two 50-kilometer (31-mile) flights carrying a passenger, within a week's time.

After spending several days overhauling and testing his motor, which had been giving some trouble through loss of lubricating oil, and also after fitting a pair of new propellers which were larger and of slightly greater pitch, Mr. Wright on October 3 again resumed his experiments. After testing the new propellers in the morning in three short flights of 4 minutes 51 seconds, 9 minutes 31 seconds, and several minutes respectively, and again in the afternoon in a longer flight of 18 minutes 24 seconds, Mr. Wright took George B. Dickin, Paris correspondent of the New York Herald, as a passenger on a 3-minute 21-second flight. His description of the sensations he felt is interesting. In starting, the sudden rush forward was much like the sudden drop on a water-toggan, or roller coaster, but once the machine was soaring, he felt perfectly secure, and found the swift motion through the air much more pleasurable than when in an automobile, as it was unaccompanied by any shock or jar, though the noise of the unmuffled motor beside him was almost deafening. The higher the machine flew, the slower it seemed to be traveling; while when it was near the ground, the sensation was much like that experienced in an automobile. There was no shock in alighting. The two strongest impressions received by this passenger were the apparently increased size of the aeroplane while in flight and the very great security and stability in making the turns.

At dusk the same evening (October 3) Mr. Wright, with Franz Reichel of the Figaro as passenger, made a record flight of 55 minutes 37 seconds, during which he traversed a distance of fully 58 kilometers (36 miles). It was shortly before 7 P. M., and dark save for the moonlight, when the flight terminated. In making it Wilbur Wright fulfilled the first half of his contract. His previous longest flight with a passenger was 11 minutes and 35 seconds. According to calculations made by Aero Club officials, the aeroplane in its morning flights attained a speed of over 74 kilometers (45.95 miles) an hour with the wind and 54 kilometers (33.53 miles) an hour against it, while in the afternoon the average speed was figured to be 61 kilometers (37.88 miles) an hour.

On Monday, October 5, Mr. Wright tested the weight-carrying properties of his aeroplane by making three flights with heavier men as passengers than he had taken up before. First he took M. Leon Bollee, who weighs 233 pounds, on a 4-minute flight, and afterward M. René Peller, whose weight is 194 pounds, on a 2½-minute and a 7½-minute flight respectively. No trouble was experienced in rising in the air, and the flights were made with great steadiness.

The next day, October 6, Mr. Wright made the second long-distance flight with a passenger, and thereby fulfilled the conditions of his contract. This time, with Mr. Arnold Fordyce as passenger, he remained aloft 1 hour, 4 minutes and 26 seconds. The average height during the flight is given as about 72 feet, and the distance covered slightly over 40 miles, which shows the machine to be quite capable of fulfilling the conditions laid down by our own War Department.

After having successfully fulfilled the conditions required of him before the purchase of his French patents for \$100,000, Mr. Wright, during the next few days, took up numerous passengers on short flights of from 2 to 4 minutes' duration. On October 7, after first making a 3-minute 24-second flight with Mrs. Hart O. Berg, he took Mrs. Berg on a short flight of 2 minutes and 3 seconds duration. Mrs. Berg was the first woman to fly in a Wright aeroplane, and so delighted was she with the experience that she induced Mme. Bollé to make a flight the next day. On October

7 Mr. Wright also took up Michalo Pulo, an 11-year-old boy, in one of his flights. Among those who went with him on this and the following day were M. Paul Jamin; M. Soldatenkoff, an *attaché* of the Russian embassy at Rome; Sargeant Kasnakoff, Messrs. Butler, Brewer, and Rolls, Major Baden-Powell of England, and Commandant Bouttleaux of the French Aeronautic Corps. With the latter officer Mr. Wright attained a height of about 75 feet. Among the spectators was Queen Margherita of Italy.

So enthused have the French people become over Mr. Wright and his performances, that a public subscription for a testimonial to him has been opened at Le Mans. The gold medal of the Governing Committee of the Aero Club of France has also been awarded to him.

Manufacture and Uses of Levulose or Fruit Sugar.

Levulose, or fruit sugar, is little known to the general public. It is sold only by druggists and the cost of manufacturing it by the methods now in use is so great that the price of levulose is nearly a dollar a pound. This variety of sugar possesses properties which would bring it into extensive use if its cost were not prohibitive.

The only process by which chemically pure levulose can be produced cheaply in large quantities is based on the employment of inulin as the raw material. Inulin is a variety of starch which is found, in proportions of 8 to 11 per cent, in the roots of chicory and the tubers of the dahlia. The dahlia is a native of America and was introduced into England in 1789 and into Germany in 1812. It was supposed that the tubers would be a valuable food for cattle, but the cattle refused to eat them, and therefore the dahlia has been cultivated for its flowers alone. Yet dahlias could be raised as easily and almost as cheaply as potatoes. They are propagated by division of the tubers which, with special culture, may attain a weight of more than a pound. Chicory root is well known and is raised in immense quantities in Germany, Austria, France and Belgium for the purpose of mixing with coffee.

The manufacture of pure levulose from chicory or dahlia tubers is very simple. In the first place the inulin is extracted from the tubers by boiling them with lime water. The inulin is then converted into levulose by the action of dilute acids.

The field of application of levulose is very extensive. Levulose is sweeter than ordinary sugar and it possesses other advantages over the latter. In particular, it can be eaten with impunity and completely assimilated by the majority of diabetic patients. It is also recommended in acidity of the stomach and in recent years several eminent physicians have advocated its use as a food for consumptives. It may also be substituted for milk sugar in the preparation of infants' foods. In the manufacture of bonbons, jellies, marmalades and fruit preserves it possesses the advantage of neither crystallizing nor becoming turbid, and from it can be made an imitative honey which does not solidify and which is almost identical with natural honey, of which levulose is the principal ingredient. In the preparation of beer, wines and non-alcoholic beverages levulose will also be found very useful. From inulin an excellent bread for diabetics can be made.—Umschau.

The Cost of a Panama Hat.

Panama hats are made in Colombia, Peru, and Ecuador, but never in Panama. The value of a Panama hat is chiefly the cost of the labor expended in making it, for the value of raw material never exceeds 35 cents, and averages less than 13 cents. The labor is exceedingly cheap, but a great deal of it goes to the making of a hat. It takes a man, working six hours a day, six or seven days to make a common hat, worth a dollar. Two weeks are required to make a hat of better grade, worth from \$1.25 to \$3.00, and six weeks to make a fine hat, worth \$20.

In making a fine Panama hat the straw is never dampened, and consequently the work can be done only when the air is very moist, that is to say, early in the morning, and in the evening. The straw used for cheap hats is kept wet, so that the work can be carried on during a greater number of hours per day.

Second Contest for the Scientific American Heavier-than-Air Trophy.

It is announced that the next contest for the SCIENTIFIC AMERICAN heavier-than-air or aeroplane trophy is to be held at Morris Park, Bronx Borough, in this city, on November 3, under conditions much more severe than those of the first contest at Hammondsport, N. Y., in July last.

The experiment on the elevated railway lines in Chicago to eliminate noise by the use of a gravel road-bed on the structure, has recently been abandoned, as the gravel not only failed to reduce the noise, but held water, with injurious effects to the structure.

Correspondence.

Turbine Propellers.

To the Editor of the SCIENTIFIC AMERICAN:

Having followed through the columns of the SCIENTIFIC AMERICAN the development of the marine steam turbine, and having read with great interest the article entitled "Turbine Propellers" in the SCIENTIFIC AMERICAN SUPPLEMENT of August 8, 1908, I fail to see the advantage of placing the low-pressure turbine propellers in the wake of the high-pressure propellers, as in the "Lusitania" and "Mauretania."

When two force pumps are connected in series, the discharge of the first being the suction of the second, the latter must work twice as fast to be of the same efficiency. When two paddle wheels are placed one ahead of the other, as in the steamer "Bessemer" in the article above referred to, the aftermost wheel should either revolve faster or be of wider tread, because, as therein stated, the second wheel is called upon to give an added impetus to water already set in motion by the first. For the same reason, when two screw propellers are placed tandem on one shaft, the hindmost one is at a great disadvantage in rotating at the same speed as the foremost, unless it be of larger diameter. The circle made by its blade tips should be twice the area of the similar circle made by the blade tips of its forward shaft-mate.

In the original Parsons "Turbinia," the high-pressure shaft was in the center and farthest aft, while the intermediate and low-pressure were on either side and forward of the central one. Thus the slower rotating propellers took hold of stationary water, while the faster-turning high-pressure propellers gave the added impetus to water already in motion.

In the "Lusitania" the high-pressure propellers are forward, and the low-pressure ones aft; so that the high-pressure shafts are doing nearly all the work, while the slower-turning low-pressure shafts in their wake are at a great disadvantage. If their positions were reversed, the high-pressure shafts aft, and the low-pressures forward, the load would be more evenly distributed, and greater efficiency and speed would result.

H. B. NEWTON.

Santa Rosa, Cal.

An Important Patent Law.

To the Editor of the SCIENTIFIC AMERICAN:

One of the most important pieces of legislation passed in years is the amendment to the Legislative Appropriation Bill. (Public No. 130, H. R. 16,682, approved May 22, 1908.) This amendment is as follows:

"For rent of rooms in the Union Building for Patent Office model exhibit during so much of the fiscal year nineteen hundred and nine as may be necessary, and for necessary expenses of removal and storage of said exhibit, nineteen thousand five hundred dollars. Provided, that a commission, which is hereby created, to consist of the Secretary of the Interior, the Commissioner of Patents, and the Secretary of the Smithsonian Institution, shall determine which of the models of the Patent Office may be of possible benefit to patentees or of historical value, such models thus selected to be cared for in the new National Museum building. The remainder of said models shall before January first, nineteen hundred and nine, be disposed of by sale, gift, or otherwise as the Commissioner of Patents, with the approval of the Secretary of the Interior, shall determine."

The above Act of Congress, appointing the above-named model commission, clearly specifies that said commission "shall determine which of the models of the Patent Office may be of possible benefit to patentees and of historical value." The Act does not say that the members of the Model Commission shall merely express their opinions as to the "possible benefit to patentees or the historical value" of the Patent Office models; nor that some one else for the Commission shall determine the status of the models; nor that the Commissioner of Patents shall dispose of or prepare to dispose of, or that anyone else for the Commissioner shall dispose of or prepare to dispose of any of the Patent Office models, before the Model Commission have "determined the possible benefit to patentees or the historical value" of the models; but the Act does limit the power of the Commissioner of Patents by the action of the Model Commission, and does fix the terms on which the commission's action shall be based.

There are 157,000 models in the Patent Office collection. These models form an integral part of the patent system. They can no more be destroyed than the files of the Patent Office can be destroyed. These models cover the history of the main industrial arts of the last century. They directly relate to nearly every field of industry, and include all kinds of mechanical movements: cams, gears, levers, brakes, clutches, bearings, wheels, motors, housings, joints, cutters, and devices and machines that have never been properly studied nor adequately described.

Practically all of the inventions disclosed by these models are now public property by reason of the expiration of the patent franchise. Commissioner Moore

is authority for the statement that many of the Patent Office drawings do not disclose the inventions they cover. But, he says, the "models always do." Destroy the models, and you destroy the means by which the public can secure knowledge of their property; destroy the models, and a precedent is at once established for destroying other records. What inventor will grant anyone the right to annul his rights, or weaken the value of his patent properties? The patent records establish priority, and on priority all patents are based. But why should any records be destroyed, why should dangerous uncertainties be placed around existing patent rights, and the status of the Patent Office lowered in the eyes of the world? Who is to benefit by the destruction of any model, however worthless it may be of itself? Why this haste to destroy records of human initiative that have never cost the nation a cent, and now cost the inventors only fifteen cents a year on the average? Surely, no one desires to establish an irregular standard of fixing priority. The inventors must meet the question full in the face.

At the present time there is a surplus of nearly \$7,000,000 to the credit of the inventors. Instead of Congress formulating measures to develop the patent system and to encourage the production of invention, instead of Congress preparing plans by which the inventors' money may be spent for the inventors' and the nation's good, it smuggles an amendment through to seriously disable the patent system, and which can but seriously discourage every honest inventor. The manner in which the amendment was prepared, the manner in which it was passed, all indicate a desire on the part of somebody to destroy the models regardless of their value. But even if all the models deserved destruction because of their intrinsic worthlessness, they deserve conservation because of their extrinsic worthfulness.

When one compares the administration of the Patent Office with the administration of the Department of Agriculture; when one compares the Patent Office building, with its complete lack of fireproof facilities and file vaults with the magnificent Library of Congress, the evidence of Congressional inattention and consistent neglect accumulates. The time has come when the inventors should vigorously confront Congress with their grievances, and its members convinced that the inventor is not now treated justly by the government, or the Patent Office provided with proper facilities for carrying on its work, or invention properly encouraged by the national government.

The Patent Office has repeatedly solicited the active interest of the inventors, and the appointment of the Model Commission presents a magnificent opportunity for the inventors to express in definite and useful terms their needs and grievances.

Before the Model Commission can intelligently "determine the possible benefit to patentees or the historical value of the patent models," the commission as a commission must freely consult with the patentees and the historical societies. Before they can intelligently consult with the patentees or the historical societies, the commission will be compelled to catalogue, classify, and describe the models, so they and the inventors may know what they are discussing. This classification would be incomplete and of little use to the mass of the people or to the commission if it did not comprehend the growth of civilization in all of its many phases: the climatic, the geological, geographical, biological, racial, age, political, tribal, communal, agricultural, industrial, intellectual, religious, economic, consumptive, distributive, democratic, despotic, military, creative, scientific, mechanical, educational, and aesthetic.

If the Model Commission will consistently and fairly attempt to determine the inventive and historical value of the Patent Office models, it will bring about a profound and wholesome discussion of present inventive needs that will do much to restore lost inventive leadership to America, and definitely help to secure leadership in discovery for this country.

There have been two fires in the history of the Patent Office, and no adequate provision has been made against a third, which is likely to occur at any time; and if it did occur, it is more than likely that the Patent Office would be a mass of ashes a few hours after the fire got a good headway. After the first fire, which occurred on December 15, 1836, Henry L. Ellsworth, then Commissioner of Patents, said: "Interest, sympathy, and patriotism will unite to repair the loss. Justice demands all the reparation that can be made. Government has received from industry and ingenuity their choicest tributes. She confided the valuable repository to a place of little security. I have mourned in common with others at the ruin, but candor compels me to say that without much help I can do nothing to repair the loss. I leave, therefore, with the National Legislature the opportunities of those I am compelled to hear, but which I have not the power to relieve." The Hon. John Ruggles, chairman of the Senate committee having charge of the erection of a new Patent Office building, in his report

to the twenty-fourth Congress, second session, said: "In examining the subject referred to them, the committee have been deeply impressed with the loss the country has sustained in the destruction by fire of the records, original drawings, models, etc., belonging to the Patent Office. They not only embrace the whole history of American invention for nearly a half of a century, but were the muniments of property of vast amounts, secured by law to a great number of individuals, both citizens and foreigners, the protection of which must now become seriously difficult and precarious. Everything belonging to the office was destroyed, nothing was saved. There were 168 large folio volumes of records and twenty-six large portfolios containing nine thousand drawings, many of which were beautifully executed and very valuable; there were also all the original descriptions and specifications of inventions, in all about ten thousand, besides caveats and many other valuable papers. The Patent Office also contained the largest and most interesting collection of models in the world, there being about seven thousand."

The second fire in the Patent Office occurred in 1877, when about 87,000 models were destroyed, and a large number of important records. A few of the models that were generally regarded as of great importance were restored, and most of the records were replaced, so far as was possible. The Commissioner of Patents in his report of the fire (Official Gazette, October 9, 1877) remarks: "If the above statement (the one of Senator Ruggles) was true in 1836, what might be said of the model room of the present time? Seven thousand models comprised what was then called the grandest collection in the world. If such solicitude was felt for its welfare when the patent system was just gaining a foothold, what could be said of it at the present day? And how varied are the interests affected, and what multitudes are thrilled at the destruction which has overtaken so large a portion of these representatives of American skill and industry."

In his report of 1878 Commissioner Ellis Spear said: "The mind cannot grasp, no data can be collected to state, the vast results of American invention since 1836. . . . The records of the Patent Office, as well as the history of our manufactures, show the immense labors and achievements of inventors during the last half century. But the end in no department is not yet reached. The fields of invention are exhaustless, and under protection wisely given, the future will be richer in inventions than the past."

Lester Ward in his magnificent work, "The Psychic Forces of Civilization," says: "Civilization has really advanced in exact proportion to the extent to which society was prepared to employ the arts brought out by the inventive genius of a small proportion of its members." (See page 191.)

What a singular contrast between 1836, 1877, and 1908! Instead of an increase in public appreciation, we find evidences of legislative antagonism to invention, for no matter how beneficial the Model Amendment may be made, the fact remains that it was conceived in a spirit of indifference and antagonism. Let the commission open the question for discussion and let the inventors vigorously discuss the question.

Washington, D. C.

JOSEPH J. O'BRIEN.

The Current Supplement.

James N. Hatch in the current SUPPLEMENT, No. 1711, traces the development of the electric railway, and shows to what it has developed from insignificant beginnings. Mr. T. Kennard Thomson concludes his excellent presentation of pneumatic caissons, in which he shows the exact manner in which they are employed in engineering construction. Recently there was inaugurated what in the eyes of the Mohammedan faith ranks as the most important railroad in the world, that extending from the city of Damascus in Palestine through the wild mountain ranges and expanses of the Arabian desert to the sacred cities of Medina and Mecca. The English correspondent of the SCIENTIFIC AMERICAN describes this road in detail. Dr. D. T. MacDougal contributes an excellent article on the seasonable activities of plants. Dr. Charles Denison exhibited at the International Congress on Tuberculosis a model of a house constructed of hollow-cement blocks, with cement roof tiles or shingles, and reinforced concrete floors. The houses are described and illustrated. Dr. Ludwig Günther writes popularly and instructively on ultra-violet rays. J. E. Gore presents some astronomical facts and fallacies which he has collected from various sources, and which are not usually mentioned in books on astronomy. The usual engineering notes, electrical notes, and trade notes and formulæ are published.

The best preventive for spontaneous ignition of coal, says Compressed Air, is a small cylinder containing compressed carbon dioxide, fitted with a fuse plug melting at 200 deg. F. A cylinder one foot long and 3 inches in diameter is sufficient to take care of 8 tons of coal.

A RESCUE TRAINING SCHOOL AND EXPERIMENTAL GALLERY FOR MINERS.

BY THE ENGLISH CORRESPONDENT OF THE SCIENTIFIC AMERICAN.

A unique institution has recently been inaugurated at Howe Bridge near Atherton, the center of the Lancaster coal-mining district of Great Britain. This is the Rescue Training School, where miners are instructed in the use of various rescue apparatus for succoring their comrades after a colliery disaster. The organization owes its foundation to the necessity of some such means of instructing miners in this class of work.

The English undertaking has been established and partly maintained by the Lancashire and Cheshire Coal Association. Several members of the association have not actively entered into the scheme, while, on the other hand, certain other colliery companies who have no connection therewith are giving it their support. The scope of the enterprise is the provision of a training school and gallery in which is reproduced the underground working of a colliery, presided over by a permanent and skilled instructor, who will teach classes of men sent from the respective collieries the use of the apparatus and the methods of working underground after a calamity. The classes will be composed of men selected by the particular colliery equipped with the apparatus. All expense for instruction will be defrayed by the colliery, the class simply going to the school periodically for training. Should a colliery be unable to cope with an accident, it could easily telephone for assistance to one of the surrounding colliery companies, and in this manner a large and efficient force could be easily and quickly collected.

The gallery resembles a long corridor forming three sides of a rectangle, each 50 feet in length, built of masonry. Within this a gallery is reproduced even to the rock roof supported by timbers, leaving workings about 3 feet or 4 feet in height, with the floor undulating, rough, and rugged, as it is in the coal mine. There are two of these galleries, placed one above the other, and where the level of one rises, the other dips, and *vice versa*. The outer wall of the gallery is glazed, so that the men within are continually under outside observation. Should an accident occur to any man within, such as the failure of his apparatus, or any other mishap, he can at once be secured and brought into the outer air through one of the windows. Because the two galleries are ar-

ranged in the switchback manner, with opposite rising and dipping of the floor, both are within view of the observer at once. The interior of these galleries is filled with an absolutely irrespirable atmosphere, derived from the combustion of sulphur and other asphyxiating smoke. Along the center of each gallery extends the narrow tramroad, such as is laid in mines

mine which is the most satisfactory and efficient for all-round working, and its general adoption by the colliery companies participating in the maintenance of the institution. That which is finally selected as conforming with these conditions will be determined as the standard apparatus. The instructor will then be dispatched to the makers of the standard apparatus adopted, for a complete course of instruction in its use, and will thus be in a position to impart the necessary instruction to the various teams.

Six different types of apparatus have been entered in competition. These comprise the "Weg," already in use by the Normanton collieries in Yorkshire; the "Aerolith," in which liquid air is employed; the "Fleuss," "Draeger," and the "Clarke Stevenson" and "Valor" appliances, these two last named being recent inventions.

The tests imposed are exacting, and similar to the work that would have to be carried out underground after an explosion. In the vitiated atmosphere the complete length of the gallery, aggregating 150 feet, has to be traversed, props set, ventilation walls built, brattice cloth fixed, and a "dummy" miner weighing 170 pounds carried through the workings on a stretcher.

The team comprises four men, and before donning the apparatus each man is thoroughly examined by a committee of physicians to decide his physical suitability for the arduous work. Several other physicians are retained to stand by in case one of the men has to be summarily withdrawn from the gallery through one of the windows because of the failure of his appliance. Upon entering the gallery the team has to travel twice over the whole road, the total length of the course both over and under. Twelve props then have to be taken from X and set at A and H, six props at each point. The team must then travel by the upper road to F, load 250 bricks in a tub, and take them to F and J, while a brattice cloth has

to be fetched from F and set at D. Traveling back to X along the lower road, a stretcher is secured and taken by the upper road to F, where the recumbent dummy is found, which must be placed on the ambulance and brought back to X by the upper road. From X progress has to be made to D, the brattice cloth taken down, rolled up, and deposited at F. The bricks are then removed from F to J and replaced as originally found, while the twelve pit props are withdrawn from A and H and replaced at X. The test, as experience has already shown, has proved sufficiently exact-

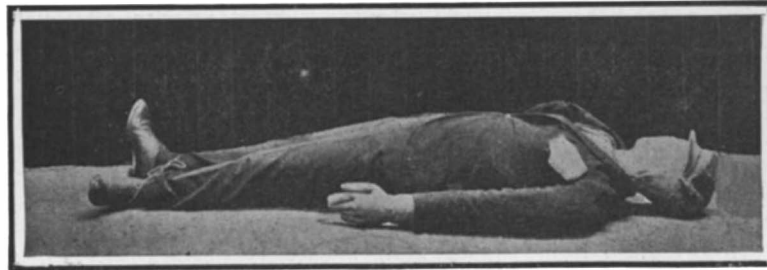

The dummy which must be carried on a stretcher.



The cycle ambulance ready for use.

for the transport of the coal from the working face to the main shaft; and furthermore, the gallery is blocked with various obstacles, such as result when an explosion occurs. The interior of the gallery, when charged with the noisome gases, is freely lighted with electric incandescent lamps, which throw a slight glimmer of sufficient intensity for the observer to follow the movements of the men within.

When the institution was opened, a series of practical tests with the various rescuing appliances introduced to the market was arranged, in order to deter-



The Draeger apparatus, which was recently used in a mining disaster.



Simonis ambulance bicycle, which can be converted into an ambulance in three minutes.



Two miners equipped with the Fleuss apparatus.



Front view of the Weg apparatus.



The "Aerolith" apparatus.

ing, the whole cycle of operations occupying two hours, during which time the gallery must not be left. The rough nature of the road, the cramped headway, the murkiness of the atmosphere and its poisonous condition, combined with the almost total darkness, impose a severe strain upon the men's nervous system. Upon issuing from the gallery, each man is again medically examined. In this manner conclusive data concerning the effect of the respective apparatus upon each man and his physical capabilities for such work are secured.

The team equipped with life-saving apparatus passed through their ordeal with complete success, and emerged from the gallery showing but slight traces of exhaustion. This no doubt was due not only to the efficiency of the appliance, but to the fact that they had already passed through the ordeal of a real catastrophe, since they accomplished heroic work at the Hamstead colliery, and had no doubt become accustomed to the peculiar surroundings and working within a confined breathable atmosphere as represented by the mouth-piece.

NEW FOSSIL WONDERS FROM THE FAYUM OF EGYPT.
BY WALTER L. BEASLEY.

Prof. Henry F. Osborn, who planned and directed the expedition of the American Museum of Natural History to the Fayum Desert of Egypt, made possible through the generosity of the late Morris K. Jesup, is just now placing on exhibition some of the remark-

able and interesting fossil remains there discovered—remains which illustrate the peculiar and little-known ancient land animals of Africa. These brilliant researches and successful explorations of Prof. Osborn have not only added much to earlier discoveries, but

After awaiting the appearance of the monograph compiled by Dr. C. H. Andrews of the British Museum, setting forth the prior field work and discoveries of the Egyptian Survey, which released in a sense the region to other investigators, Prof. Osborn seized the exceptional opportunity of forming an expedition in order to unearth possibly unknown types of the former mammalian life of Africa. Through energetic and systematic excavating and quarrying, the expedition recovered some 550 specimens, including the more or less complete remains of nearly all the fossil forms so far known to be characteristic of this famous region, together with several new members of animal types and families, hitherto not encountered by previous collectors. These include several species of primitive carnivores and two genera of rodents.

The Museum expedition left New York in January, 1907. Mr. Walter Granger, an able fossil explorer of fourteen years' experience of work in the Bad Lands of western America, and Mr. George Olsen, a Dane,

highly trained in the technique of the getting out and preservation of fragile and delicate remains, were selected to conduct the field work and prepare the specimens for transportation. On February 5, 1907, just a month after leaving New York, the American caravan of twenty-one camels and eight tents and a complete camp outfit for life in the desert, together with twenty-five Arab, Bedouin, and Egyptian workmen, reached the Fayum, the goal of the expedition. Vertebrate fossils were first discovered in this region in 1879 by

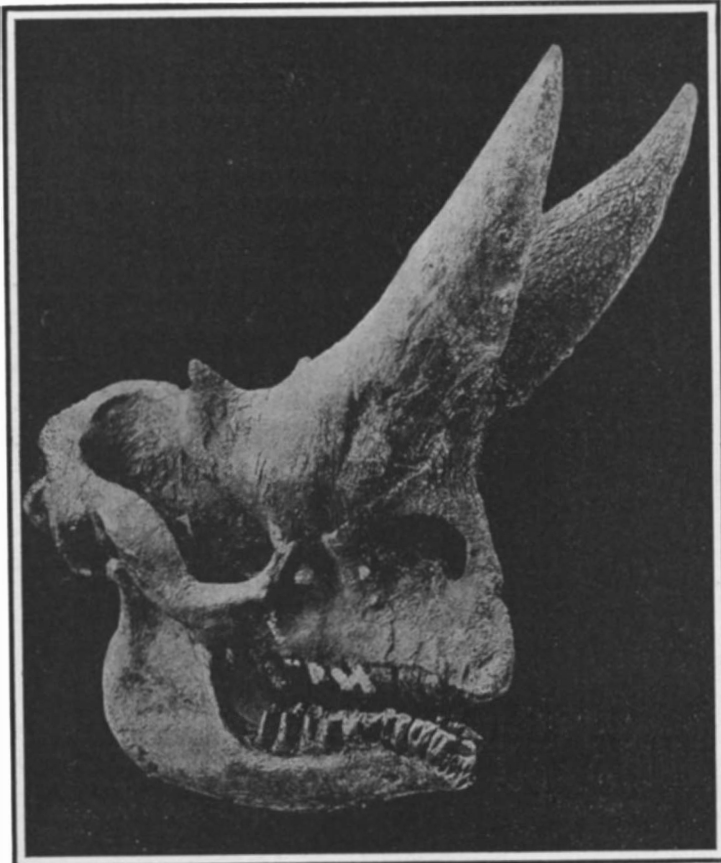
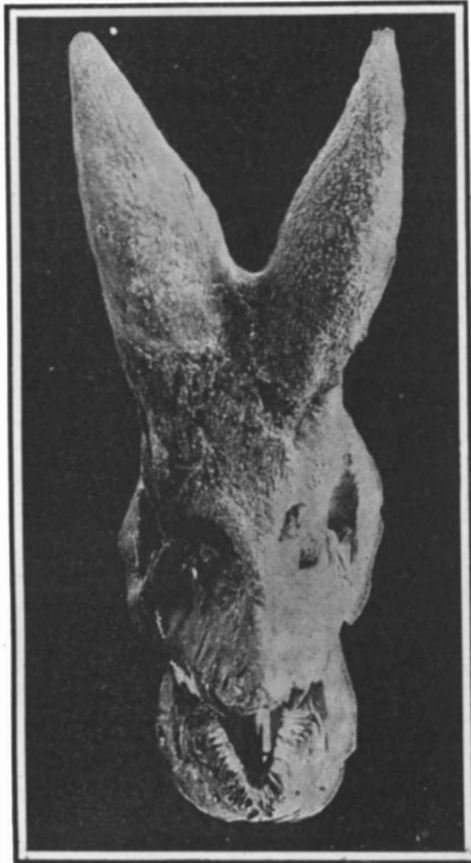

Figs. 2 and 3.—Front and side views of the *Arsinoitherium* skull now in the Cairo Museum, found by the Egyptian Geological Survey.

have thrown new light on the little-known animal world of ancient Africa. The "Dark Continent," hitherto supposed of little paleontological interest, proves surprisingly rich in early fossils, including types hitherto unknown. Through the courtesy of Prof. Osborn, the writer was afforded facilities for presenting in the pages of the *SCIENTIFIC AMERICAN* a general narrative, covering the main features and scientific results of this the first American paleontological expedition into Egypt's famous fossil country.



Fig. 4.—The finding of the great skull of the *Arsinoitherium* in the Fayum Desert, Egypt.



Fig. 5.—The American Museum Expedition entering the Fayum Desert, Egypt.



Fig. 6.—Egyptian and Arab helpers at work in the fossil quarries. Specimens were found six and eight feet below the top of the sandy surface.



Fig. 7.—Mr. Olsen and Egyptian workman preparing the fragile desert fossils for transportation to New York.

the German explorer Schweinfurth, but no collecting of importance was done until 1898, and then by Mr. H. J. L. Beadnell, of the Geological Survey of Egypt, and Dr. C. H. Andrews of the British Museum. In 1901 the discovery of land animals was first announced. Between 1901 and 1905 a vast number of fossils were collected, which are now in the Cairo and London museums. The Fayum district is a natural depression about fifty miles in diameter situated in the Libyan Desert, fifty miles southwest of Cairo, and separated from the Nile valley by a narrow strip of desert land. In this basin was the ancient Lake Moeris, some 300 feet above the present brackish shallow sheet of water now known as Birket-el-Qurun. This depression is divided into a series of terraces, or fossil-bearing beds, some reaching to the height of 1,000 feet. These imposing formations rise tier upon tier, amphitheater-like. The principal bone-bearing layer, composed of loose red sand in which scattered bones could be seen imbedded, was only forty feet in thickness, but miles in horizontal extent. It was along the northern shores and in the Upper Eocene deposits or fluvio-marine that the expedition carried on the most energetic search and secured the most specimens.

Just why the astonishing and extraordinary number of the ancient animals of Africa found their burial place in this particular spot of the Fayum, is attributed by Prof. Osborn to the following circumstances: In remote times, long before the Nile had come into existence, a mighty river flowed north and emptied its waters into the Mediterranean, then 140 miles south of its present boundaries. Here, at this point, a sandbar had checked the river current. The animals had evidently drifted some distance downstream with the sand and gravel, all the bones floating apart or having been pulled apart by turtles and crocodiles, so that a skeleton of an animal could never be found intact. In this manner animals of every kind, big and little, herbivorous and carnivorous, in every degree of preservation, a few being hard and perfect, others soft and crumbling, had been washed down and heaped together. In every case the bones were only partly petrified, a condition entirely different from the hard and rocklike state in which fossils are found in the sandstone matrix in western America. Seldom were two bones of one animal found together. The skulls were as a rule badly broken.

Camp was pitched midway between the two large quarries which had been opened by the Egyptian Survey, in which the Museum party were permitted to dig. These were strewn with heaps of bones discarded. Here the bone layers were from four to six feet below the surface. The force of Egyptian workmen, as directed and coached by Messrs. Granger and Olsen, were soon trained into first-class excavators. Their tools were the primitive mattocks, and baskets to dump the large quantities of loose sand. A few were picked men who had worked for the Survey Department previously, and were familiar with the handling and getting all the labor possible out of the slow-moving sons of the desert. They received forty cents a day, and additional reward for the finding of a large and important fossil. Several of the accompanying illustrations show these men at work in the desert quarries. On the top of the delicate and crumbling bones, often mere powdered dust, shellac was poured, and not until the specimen was hardened, could it be removed safely from the sand. In about a fortnight's time, one of the most important and significant finds was made, in the shape of the skull of the giant *Arsinoitherium*, one of the most extraordinary land mammals of ancient Africa, or of the whole known fossil world. This remarkable beast is entirely new to science and paleontologists. Its existence was unknown and undreamed of until a few years ago.

The dominating and all-powerful feature of the *Arsinoitherium* was the long pair of sharp-pointed horns, protruding upward and outward above the nose for nearly two feet, an appendage both dangerous and fantastic. Undoubtedly no contemporary could cope with and withstand a mad rush and furious charge

from an animal thus armed. *Arsinoitherium* was the brute king of the Fayum during Eocene times, some two or three million years ago. The discovery of this strange beast by the members of the Egyptian Geological Survey only a few years back, is said to have afforded one of the greatest surprises of modern paleontological explorations. From the skull and other bones secured by Prof. Osborn's party, together with the material of English investigators, the make-up of the queer animal's body has been pretty accurately determined. Of exceptional interest, therefore, is the spirited and realistic restoration of this giant inhabitant of the Egyptian Fayum, as seen from the accompanying drawing by Mr. Charles R. Knight, the well-known animal artist. His picture gives a vivid

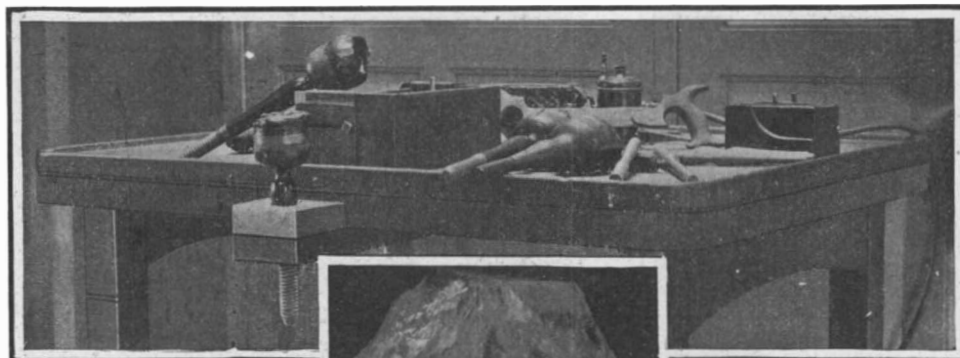

Implements used in



The Cullinan diamond $\frac{1}{4}$ size.

splitting the diamond.

glimpse of the life appearance of this wonderful horned beast, and depicts a scene of probably frequent occurrence in Eocene Egypt. The animal's body combined the shape of the rhinoceros and elephant. The monster was named after the Egyptian Queen Arsinoë, famous for her beauty. She was the second wife of Ptolemy II. (285-227 B. C.), and after her death the patron goddess of the Fayum. The animal stood about six feet high and was nearly ten feet in length; the bones of the skeleton were massive and the body heavy. The neck was short, and could be freely moved up and down, and was therefore well adapted to toss an enemy up in the air. The feet were short, the five toes spreading out like those of the modern elephant. The teeth consisted of high-crowned, sharply-crested grinders, fitted for grazing upon the harder kind of herbage. The narrow muzzle of the head indicated that the animal did not

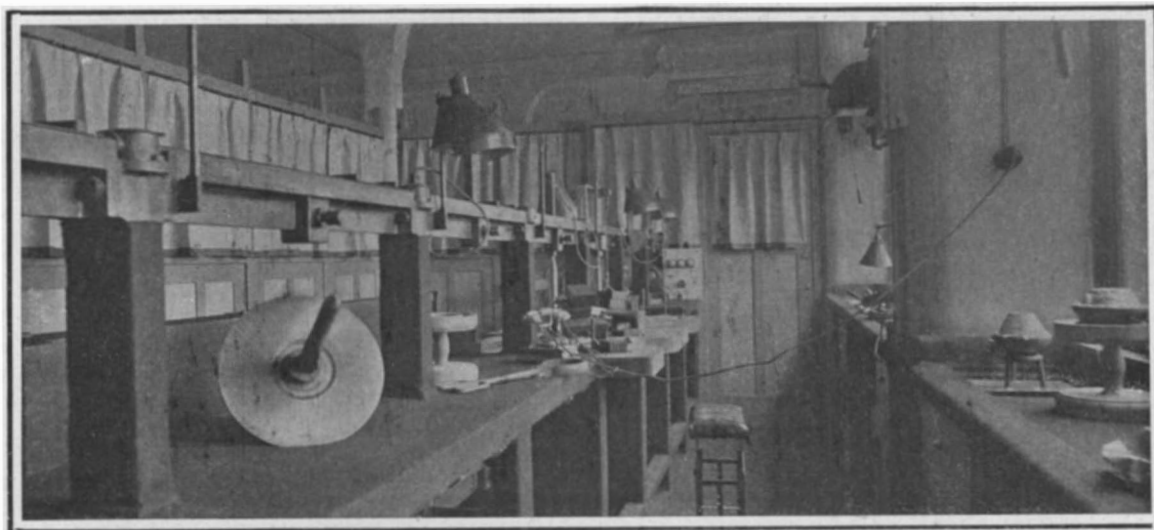

THE ROOM IN WHICH THE CULLINAN DIAMOND IS BEING POLISHED, SHOWING THE STEEL DISK IN THE FOREGROUND.

graze, but browsed upon the low bushes and herbage. As to the character of the landscape and the natural environment surrounding the primitive group of animals inhabiting the area of the Fayum and the Libyan Desert in the days of *Arsinoitherium*, Prof. Osborn advances the opinion, based on the structure of the fossilized remains, that it was a savannah country, partly open, partly wooded, with about the same temperature as to-day. The animals were those which might have lived almost exclusively in a fairly well-watered delta or estuary country bordering the sea, not densely forested, but with stretches of sandy plains or muddy bottom lands, traversed by large streams, having currents of considerable velocity. These land mammals, twenty-seven of which

have so far been discovered, with several new ones by the Museum, were all relatively short-footed and slow-moving, only two swift-running types being known, one an active carnivore. From a study of the structure of the limbs and feet, it has been determined that these ancient groups of land animals were adapted and fitted for walking on partly sandy or sinking ground. A special exhibit comprising some of the principal finds, notably the large skull of *Arsinoitherium*, and likewise a series of skulls illustrating the first stages in the evolution of the elephant, is now installed in the Fossil Mammal Hall. A popular account of the hunt for the ancestral elephant in the Fayum, and the remarkable discovery of the missing link, the little tapir-like *Moeritherium*, the earliest and first known ancestor of the elephant race, will be presented and pictured in a forthcoming article. The writer acknowledges indebtedness to Prof. Henry F. Osborn for courtesies extended in the preparation of this article and the reproduction of field photographs.

POLISHING THE GREAT CULLINAN DIAMOND.

When the Cullinan was found about three years ago it was a problem of the Premier Company as to what disposition could be made of it. Its mere size, weighing as it did something over 1½ pounds, made it unmarketable and unsalable, and to cut it up into small pieces would destroy, to a large extent, not only its intrinsic but its sentimental value. The diamond hence remained in the vaults of the Premier Company for nearly three years, when it was decided by the Transvaal government to present it to the King of England on the anniversary of his sixty-sixth birthday. In the rough the stone was valued at about \$1,000,000, and about this price was actually paid therefor, viz., \$400,000 in cash and \$600,000 representing 60 per cent of the interest they had therein, on account of the fact that the government is entitled to this percentage of the output of all diamond mines in South Africa.

Consul Henry H. Morgan, of Amsterdam, furnishes the following information concerning the polishing of the great Cullinan diamond in that city:

It was necessary in the first instance to cleave the stone in three pieces in order to remove two very bad flaws therein. This cleaving is done by first making an incision into the stone with a diamond-cutting saw at the point where it is to be split and following the grain to a depth of one-half to three-quarters of an inch. Before this cleaving operation was undertaken crystal models were made and cleaved, in order to ascertain, as far as could be known, just what would happen when the same process was applied to the real stone. After the incision the cleaver inserted into the slit a specially constructed knife blade made of the finest steel, and then with a thick steel rod struck it a hard blow and cut the stone in two exactly at the point where it was proposed it should be cut. It was an exceedingly well-executed piece of work. Not infrequently it happens that a stone flies into a great number of pieces.

The stone having been successfully split, the next and final operation is the polishing, and this process is now being carried on.

To give an idea of the hardness of diamonds, it may be interesting to state that the disk on which this diamond is being polished is made of cast iron and steel, and revolves at a rate of 2,400 revolutions

per minute. The disk will turn constantly from 7 A. M. to 9 P. M., including Sundays, for ten to eleven months before the polishing operation will be completed.

When polished it will be many times larger than the *Excelsior*, which was up to the discovery of the Cullinan, the largest diamond in the world. The Cullinan weighed in its rough state 3,027 carats. The part of the stone which is on the mill will possibly be given 58 facets, which is the number given to all other diamonds of whatever size, and it will weigh, when finished, between 500 and 600 carats.

The actual commercial value of the completed stone will be about \$2,500,000, but its unique character will possibly make it priceless.



The Editor of Handy Man's Workshop will be glad to receive any hints for this department and pay for them if available.

A HOME-MADE SEISMOGRAPH.

BY HENRY H. RIGGS, PRESIDENT OF EUPHRATES COLLEGE.

The SCIENTIFIC AMERICAN has occasionally told its readers something of the seismograph, and of the mysterious tremors and pulsations of the earth's crust that it reveals. But probably very few have ever seen one, or had the opportunity to "feel the earth's pulse" for themselves. Yet a really serviceable seismograph can be constructed by anyone with a mechanical head, with very few tools and a very small outlay. The following is substantially a description of the seismograph constructed by the writer at Euphrates College, Harpoot, Turkey. It involved an outlay for materials of less than three dollars. This instrument has been in operation for the past sixteen months, and has during that time recorded over one hundred and sixty earthquakes. The construction of the instrument is shown in the accompanying engraving.

The Steady Mass.—The fundamental part of the instrument is a horizontal pendulum, whose function it is to remain at rest during an earthquake. The mass is a sheet-iron drum, *A*, full of gravel, weighing about eighty pounds. This is fixed securely to the end of a one-inch iron pipe, *E*, whose other end rests, by a frictionless bearing, *C*, against a solid wall. The drum is also hung from the wall by a similar bearing at *C'*. The bearings are made as follows: The half-inch machine bolts, *B* and *B'*, turn in nuts which are very firmly imbedded in the wall. In a slight depression in the head of *B* a quarter-inch bicycle ball, *C*, is set, with wax. Against this ball rests a polished, hardened steel plate, *D*, slightly concave, which is tacked to the hardwood plug driven into the end of the pipe *E*. The upper bearing ball, *C'*, is set in a depression in the bent bar *F* ($1\frac{1}{2} \times \frac{3}{8}$ -inch iron) which is firmly clamped to the wall by the bolt *B'*. The concave steel plate *D'* is cemented to the iron stirrup *G*. The other end of the stirrup is formed into a hook, over which passes the suspending wire, *W*, whose ends are fastened to the ends of the rod *HH'*, which passes through the drum *A*.

Adjustment of the Steady Mass.—By tapping the bar *F* to one side or the other, the bearing *C'* is brought exactly over *C*, so that the pendulum swings out perpendicular to the wall. The bolt *B* is then turned in or out, to regulate the period of the swing. The pendulum, when disturbed, should swing back and forth once in forty or fifty seconds. Turning the bolt *B* inward shortens the period, turning it outward lengthens it. If *B* is too far out, the pendulum will not swing back and forth, but will swing clear over to either side. As it is impossible by moving the plate *F* to adjust the pendulum very exactly, a weight, *Z*, of two or three ounces, is hung by a long thread against the strut *E* a few inches from the bearing. The support from which this weight is hung can be adjusted, so as to bring more or less pressure on the strut as needed.

Multiplying Lever and Recording Pen.

—To the steady mass is connected the short arm of the multiplying lever *I*. The short arm consists of a bit of brass wire, No. 12, three inches long. It is inserted into the cork *J* (Fig. 3) which serves to join together the two arms of the lever and their pivot, *K*. At one inch distance from the pivot the brass wire is flattened slightly on top, and a conical depression is made in it. In this depression rests one point of a link, *L*, of fine piano wire, shaped as in Fig. 2. The other end of the link rests in a similar depression in the brass bar *M*, which lies on the pendulum drum. This link communicates any motion of the drum to the short arm of the lever *I*. The long arm of the lever is a stout straw, fourteen inches long. The short arm should nearly balance the long one; if necessary, a drop of solder may be added at the end of the wire. At the end of the long arm is a cross-piece, *Q* (Fig. 4), of aluminium foil, whose two ends are bent up to form a support for the needle, *V'*, whose pointed ends rest in depressions in the foil. A piece of No. 24 aluminium wire is given two turns about the needle *V'*, and cemented to it. One end of the wire, an inch long, is ground to a conical point, *S*, and bent downward so that the point rests on the drum *T*. The other end is bent up and to one side, and cut off half an inch long. A drop of wax, *R*, makes this short arm nearly balance the point. Thus

when the point is down, it rests on the drum very lightly, and when swung up, the short arm does not touch the drum. The pivot, *K* (Fig. 3), is a common sewing needle, rather fine, whose point rests in a conical depression at *N*, while the upper end passes through a fine hole in the sheet-brass yoke, *KON*. The latter is fastened to a screw to the top of the post *P*, which is an iron pipe, firmly planted in the ground, with a hardwood plug driven into its upper end.

Recording Drum and Clock.—The recording drum is a cylindrical tin can closed at both ends, with a quarter-inch shaft fastened in its exact axis. The drum must be perfectly balanced on its axis by adding wax or solder to one side or the other. The shaft rests on uprights, *U*, of thick strap iron, which are

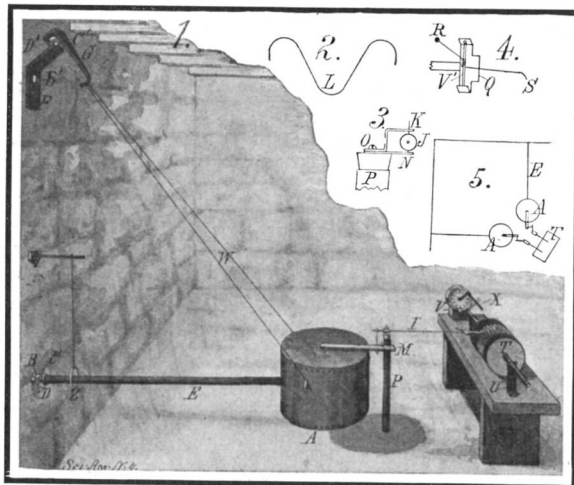

A HOME-MADE SEISMOGRAPH.

fastened to the table on which the recorder is mounted. A screw thread of about thirty turns is formed on one end of the shaft with a soft brass wire, wound spirally and soldered at each end. This thread engages the upright, *U*, and drives the drum slowly forward as it rotates. The clock is an ordinary one-dollar lever clock. It is firmly fastened on the block *V*, on the table, so that its axis is exactly in line with that of the drum *T*. The L-shaped iron wire *X* is soldered along the minute hand, and also to its bushing and pivot, so that it will rotate rigidly with the minute hand. The long arm of the L is parallel with the axis of the drum, and is engaged by a fork soldered to the end of the shaft. Thus the drum rotates with the clock, but moves gradually along its axis. On the drum is wrapped a sheet of white glazed paper, held in place by an open ring of spring wire slipped over each end of the drum. The paper is blackened by revolving the drum over a large, smoky flame, such as a kerosene torch.

Important Details of Construction.—Exact dimensions are unimportant. The drum *A* is one foot in diameter. The following points, however, are of vital importance:

1. The wall from which the pendulum is hung must be exceedingly solid. If possible it should be below ground, and not subject to great and changing strains. A lengthwise displacement of the millionth part of an inch in the upper part of the wall makes a perceptible jog in the record. Short-period tremors,

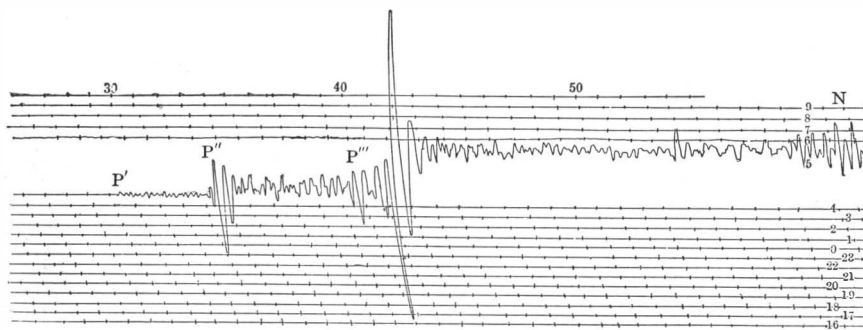

A DIAGRAM OF THE BOKHARA EARTHQUAKE RECORDED BY THE HOME-MADE INSTRUMENT AT HARPOOT, 1850 MILES AWAY.

however, such as machinery or cars near by, do no very serious harm.

2. The steel bearing plates, *D* and *D'*, after being shaped with a smooth, slightly concave surface, should be tempered file-hard, and then the bearing face highly polished with leather and fine emery.

3. The bearings of the lever *I*, the link *L*, and the stylus *RS* must be very perfect. The points of the needles, *K* and *V'*, and of the link *L* must be perfectly sharp and smooth. The conical depressions in which they rest may be made by pressing into the metal a sharp-pointed awl with a whirling motion. In regions where sharp earthquakes are sometimes felt these depressions should be rather deep, to prevent the points flying out. The needle *K* must be exactly vertical.

4. As most of the friction of the seismograph is at the point of the stylus *S*, it is of the utmost importance that that stylus should rest very lightly on the paper, only heavily enough to scratch through a moderately thin soot layer. The broad part of the cross-piece *Q* should be bent upward, so as to prevent the stylus dropping too far when the pen swings off the paper in a great earthquake.

5. If there are drafts in the room where the seismograph is installed, the instrument must be well protected from them.

Time Marking.—To be of scientific value, the records should have exact time marked on them at frequent intervals. This can easily be done if a reliable clock is available. A bit of platinum wire soldered to the second-hand wheel makes a short contact once each minute with a fixed platinum wire. These contact points are connected, through two dry cells, to the magnet of an electric bell. (Directly, not through the vibrator.) The bell, with gong removed, is rigidly attached to the post *P*, so that the strike of the armature is at right angles to the lever *I*. Thus at the end of each minute there is a sharp click against the post, which causes, as it were, a miniature earthquake, which is plainly visible in the record. The effect is improved if the clapper of the bell is replaced with a lead weight of two or three ounces.

Records.—Once in twenty-four hours, after marking on the smoked paper the exact time at the last minute mark, the paper is carefully removed, a fresh sheet put in place and smoked, and the clock wound. First the beginning of each hour is marked, and on the top line a mark is made at every tenth minute. The date, ratio of magnification, and clock error are also noted. All these are scratched in the soot on the sheet. The record is then fixed by brushing rather thin varnish over the back of the sheet. If a register is kept, at least the following data should be entered in it: 1. Time of the beginning of first preliminary tremors, *P'*. 2. Beginning of second preliminary tremors, *P''*. 3. Beginning of the first group of large or principal waves, *P'''*. 4. Time of maximum motion. 5. Amplitude of maximum motion. (Measured from position of rest of pen to extreme of motion to either side. This should be divided by the ratio of magnification of the lever *I*.) 6. Period at time of maximum. (I. e., time from one crest to the next of the largest waves.) 7. Time of end of principal portion. 8. End of succeeding tremors.

Locating a Distant Earthquake.—The writer has been able, in the case of large, distant earthquakes, to announce the general location of the shock at once, from the records of the seismograph. Two elements are needed for this—the distance and the direction. As the first preliminary tremors travel much faster than the main, large waves, the difference in time of their arrival gives a measure of the distance of the origin. Various formulæ have been computed for this, some of them very complicated. The writer has found, however, that a uniform rate of three degrees per minute is not far from the truth, for all distances; that is, for every minute that elapses between the beginning of the first tremor *P'* and the beginning of the first group of large waves *P'''*, measure three degrees of distance on a great circle of the globe. That will generally give within ten per cent of the correct distance.

To determine the direction of an origin, a single horizontal pendulum is inadequate. There must be two, set at right angles to one another, so that by compounding the two co-ordinates thus given, the actual direction of the earth's movements may be seen. The diagram Fig. 5 shows one method of bringing the records of two pendulums on one recording drum. The short arm of each recording lever is set at an angle of 135 deg. to the long arm, thus bringing the long arms parallel, as shown. One pendulum hangs north and south, and records motions of the earth east and west, while the other records motions north and south. To determine the direction of an earthquake origin, attention need be given only to the very first one or two waves of the

preliminary tremors. It is known that the first preliminary tremors are waves which, like sound waves, move in a direction parallel to the line of propagation, while the main waves have a motion at right angles to this, like light. The latter, however, are exceedingly complicated waves, while, so far as the writer has observed, the first preliminary tremors always begin with a very slight motion away from the point of origin, followed by a considerably larger swing toward the origin. So that whenever the beginning of these tremors is strongly recorded it is possible, by comparing the north-south and east-west components of these first motions, to ascertain the direction from which the waves have come. This, with the distance, marked out (on the great circle) on a globe, gives the approximate location of the earthquake.

N. B.—The writer wishes to acknowledge the assistance, in constructing this seismograph, of Prof. Marvin, of the Weather Bureau at Washington, and Prof. Milne, of the British Association Seismological Committee. Both of these gentlemen have very courteously answered questions on the general construction of such instruments.

A SIMPLE METHOD FOR MAKING A COILED SPRING.

BY A. FAGAN.

Get a metal rod the same diameter as the spring desired; drill a hole near the end to admit end of wire. Give the wire two or three turns around rod, spacing the turns according to the desired pitch.

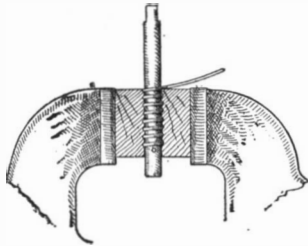

A SIMPLE METHOD FOR MAKING A COILED SPRING.

Clamp it between two blocks of hard wood in a vise, having the rod in the direction of the grain of the wood. Revolve the rod by means of a monkey wrench fitted on flattened end of rod. The wire will follow in and wind a spring as true and perfect as though it had been wound with a lathe.

A HOME-MADE WIMSHURST MACHINE.

BY JOHN R. ALLEN.

I became acquainted with two students, who were each intending to build a large Ruhmkorff's induction coil for experimental purposes. I was taking the SCIENTIFIC AMERICAN at the time, and had been reading about the Wimshurst machine. I noticed that it is very simple and cheaply made when compared to a large coil. I told the young men of it, and showed them the papers, and asked them why they did not build Wimshurst machines instead of coils. After several visits to their workshop and continued efforts to get them interested they "turned the tables" on me and said, "Why don't you build a Wimshurst machine?" And then they began to "rub it in" and repeat all I had said to them, and also hinted that I could not make one that would spark at all. I saw I would either have to build a machine or admit defeat and stand the laugh. So I went to work to build one. I did not go strictly according to the directions as laid down in the SCIENTIFIC AMERICAN SUPPLEMENT No. 548. I built the frame of oak, made the bosses of pine, got the two glass disks cut, 12 inches in diameter, used brass foil with brass hemispheres (tack heads) soldered on for sectors, sixteen on each disk. Instead of bottles for Leyden jars I used Welsbach gas lamp chimneys (the straight kind), putting the tinfoil in the middle, keeping it 1½ inches

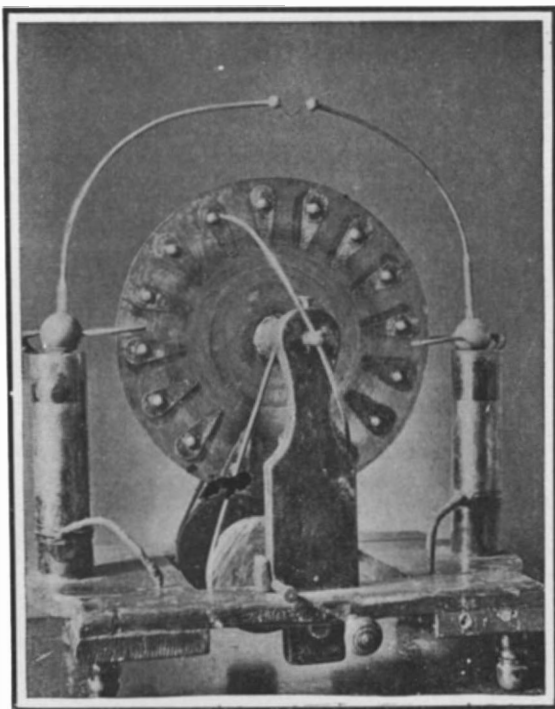

A HOME-MADE WIMSHURST MACHINE.

from each end, and then I put the posts that support the combs and terminals right through the chimneys. The posts are of hard rubber. I bored a hole into the end, and put the stem of the brass balls which connects the combs and terminals into it, and poured melted sulphur around it till the hole was full, and it makes a good fastening. The combs are connected to the inner coating of the Leyden jars. In place of

simply connecting the outer coatings of the jars together with a wire, I put two tubes into the frame in such a manner that I can connect them by putting the plug in one tube, or I can disconnect them by putting it in the other, and then put in hand bolts or any connection I like. I can also put wire in, and run it to display designs made by tinfoil strips cut at the places where the sparks are wanted to make the design or letters, etc. I used oak driving pulleys and leather cord belt. I get a 1½-inch spark when the outer coatings of the jars are connected. I photographed the machine, spark and all, by pulling down the window shades, opening the camera, and then turning the machine till it sparked several times, closing the camera, raising the window shade, and taking a picture of it in the daylight.

The students made their coils, but one of them broke down in three months and had to be rewound.

A BLACKSMITH'S NAPKIN RING.

A blacksmith friend recently presented the writer with a very neat dinner napkin ring, which he had made from an old steel shovel. A strip of steel was cut the proper length and width. The two ends were tapered down until their combined thickness was equal to the thickness of the body of the ring, which was bent into a cylindrical shape, and held in position by means of a piece of iron or steel wire wrapped around the outside. Since the steel was too thin to be welded, on account of losing the heat too quickly,

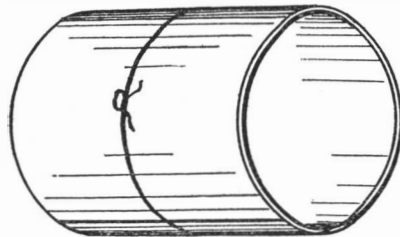

A BLACKSMITH'S NAPKIN RING.

the two ends were brazed. A thin flat piece of copper wire was put over the joint, and the ring placed upon the fire, with the joint nearest the heat. As the ring became hot, a pinch of powdered borax was thrown along the inside of it, over the joint, bringing the copper wire to the melting point, when the ring was quickly but carefully taken from the fire and dipped into a pail of water. The surface of the ring was cleaned up bright, and sent to a silversmith to be plated.

AN UNBREAKABLE LEYDEN JAR.

Two ordinary tin cans may be used to make a serviceable Leyden jar, which has the advantage of being unbreakable, according to Kosmos.

Select two tins such that the diameter of the one exceeds that of the other by about one-half inch. Cover the bottom of the larger tin (inside) with a disk of rubber or varnished cardboard. To the bottom of the smaller tin (on the outside) solder a piece of iron or copper wire, bent into a hook at the tip, or else ending in a ball. Around the smaller tin wind an old rubber plate or several layers of silk rags or well-varnished parchment, folding this insulating layer down into the tin over the edge, an inch or more. Place the smaller tin, thus insulated, with the edge down, in the larger can, and the Leyden jar is com-

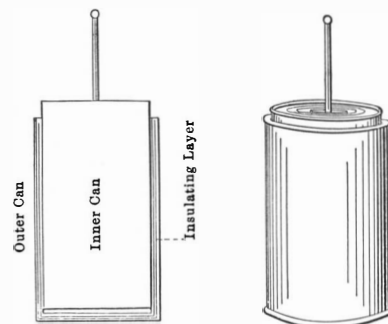

AN UNBREAKABLE LEYDEN JAR.

pleted, ready to be charged from a frictional machine or an electrophorus.

The inner tin should stand out an inch or so above the outer can, to prevent sparks from passing over.

A SIMPLE FOOT-POWER COMPOUND GRINDER.

BY A. E. OSBORN.

As there may be some amateur mechanics (particularly automobilists) who do not possess a grinding and polishing machine, although they would find such an appliance of considerable use, it is thought that the accompanying description and illustration of a machine made by the writer in about an hour's time and at practically no expense, might be of interest. The cheapness and ease with which it can be made are due to the utilization of certain parts of a bicycle

(which is usually available or can be obtained for a small sum second hand) for the driving mechanism, and to the employment of a convenient work bench or strong table as a stand. The bicycle should have as high a gear as possible (it is not injured, and can be reassembled and used on the road again) and should have its front wheel, forks, handle bar, and back tire removed. In order to support the remaining parts, two boards about 1¼ x 4 inches, reaching from the floor to the top of the bench, should be pro-

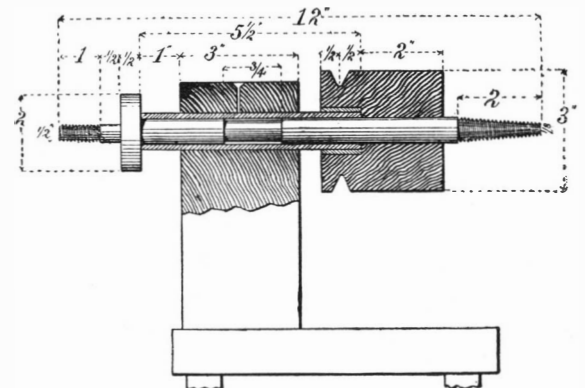

DIMENSIONS OF THE GRINDER HEAD.

vided, and these should each be drilled 16 inches from the bottom with a hole of a size to fit tightly on the nuts on the ends of the rear axle. These boards should be nailed to the floor on each side of the rear wheel, and nailed to a board at the top, so as to clamp the bicycle frame tightly between them, with the axle in the holes previously mentioned. This board should be firmly fastened to the top of the bench, and should be long enough to bring the grinding wheel in a convenient position, while its width should be sufficient to cover the tops of the axle supports. An upright board should support the head of the frame, so that the pedals will clear the floor by about 2 inches. The grinder head, used with this foot-power device, consists of a block of wood about 3 x 3 inches fastened firmly on to the top board by nails or screws, and of sufficient height to bring the grinding spindle to the desired position, a brass bushing which is of about ½-inch iron pipe size tightly fitted in a hole in the top of the block, a grinding spindle, and a grooved wood pulley. The spindle is the only piece requiring lathe work, and even this may be eliminated by using a straight rod (the bushing tube being of a size selected to fit it) and very carefully threading it with a ½-inch 12 die for the collar and clamping nut. It is, however, much more satisfactory to have a turned spindle, as it can then be made a better fit in the bushing, and the inner collar and part carrying the wheel can be turned true with this bearing surface. The part of the spindle that goes into the inner collar should be made a drive fit in the collar, and the latter should be turned while in place on the spindle. A nut and large washer should be provided for clamping the grinding wheel on the spindle. The other end of the spindle is formed with a threaded taper for polishing and buffing wheels, although it would be cheaper to leave it blank. It could also be arranged to carry a second grinding wheel if desired. The pulley which goes on this spin-

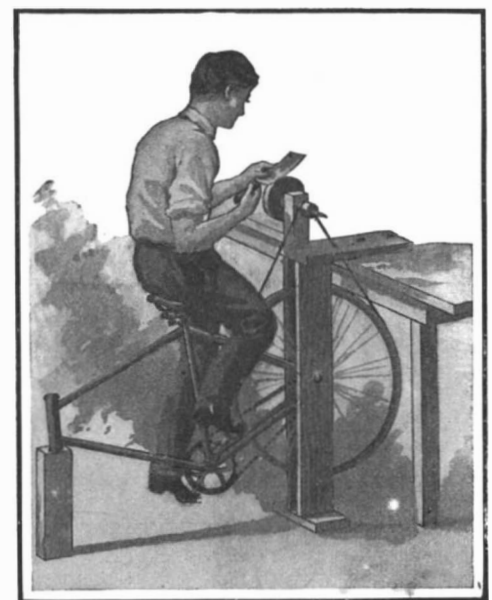

A SIMPLE FOOT-POWER GRINDER.

dle is cut (if possible turned) out of a piece of hard wood, and is bored so as to make a tight fit on spindle. If it should show any tendency to slip, a set screw can be run through it and against the spindle. This completes the machine with the exception of a ¾-inch leather belt, a grinding wheel (¾ x 6 inches is a good size) and, if desired, a tool rest which can be rigged up around the wheel.

RECENTLY PATENTED INVENTIONS.

The inventions described in this Department were patented through the Scientific American Patent Agency.

Electrical Devices.

TROLLEY POLE CATCHER.—J. H. WALKER, Lexington, Ky. The invention is an improvement on a trolley pole catcher previously invented by Mr. Walker. It consists of a carriage mounted to slide along a horizontal rack on the car roof and links connecting this carriage with a sleeve that rides on the trolley pole. The device will yield sufficiently to permit adjustment of the trolley pole to slight inequalities in the wire; but if the trolley wheel should slip from the wire the parts will operate to arrest the upward movement of the trolley pole.

Of Interest to Farmers.

CULTIVATING MACHINE.—C. SOLTÉSZ, New York, N. Y. The invention relates to the cultivating machine of the type drawn by horses. The operator walks alongside of the machine and manipulates a handle to guide the general direction of travel. The machine is fitted with pairs of cutter disks, with hoes between each pair, and the operator may move either the hoes or the cutters, or both into engagement with the ground. He can also adjust the depth of cut of the hoes or disks at will.

HARVESTER.—C. F. BLAKESLEE, Rapatee, Ill. This harvester is equipped with a draft mechanism that greatly reduces draft strain by enabling the direct transmission of progressive movement from the main driving traction wheel to the other ground wheel that supports the outer end of the grain table, thus causing the ground wheel to travel with the same speed as that of the traction wheel.

Heating and Lighting.

STOVE BASE.—J. SHARON, Canaseraga, N. Y. The object is to mount a stove base upon castors in such a way that the castors are normally in a withdrawn or inoperative position, at which time the weight of the stove base rests upon the legs. When desired the castors may be brought into an operative position so that the stove may be moved conveniently.

BOILER.—W. S. HAWLEY, Landing, N. J. The invention relates to that type of boiler in which the water is contained in a plurality of superimposed communicating sections inclosed in a casing, the products of combustion being caused to pass back and forth between the sections to heat the same. The object of the invention is to provide improvements whereby the space between the sections may be more readily cleaned, the water in the lowermost section more effectively heated, and the series of sections more effectively supported.

Household Utilities.

HOLDER.—ELIZABETH L. LLOYD, Utica, N. Y. This holder is especially designed for holding bed clothes in place on the bed, but it may also be adapted for clamping fabric generally and thus may be found useful as a towel holder, or as a clamping device for hose-supporters and the like. The jaws of this holder are in the shape of rings, one of which will pass within the other, pressing the fabric into cup-shape, and thus securing it against displacement.

PAN HOLDER AND STOVE LID LIFTER.—B. KESSLER, Cabinet, Ohio. This device may be used either as a holder or handle for pans, or as a stove lid lifter. The handle is fitted with a shank which terminates in a toe adapted to fit the slot of a stove lid. This toe may also be fitted into a fork which may be passed under a pan while a catch on the handle serves to grip the rim of the pan.

Machines and Mechanical Devices.

FOLDING BELLOWS PEDAL.—C. S. WRIGHT, Grand Haven, Mich. The invention relates particularly to automatic player pianos and provides an improved folding bellows pedal arranged to permit the user of the piano to conveniently and quickly move the bellows pedals into active position or fold them into inactive position to allow the player to use the action pedals when playing the piano by hand.

MUSIC LEAF TURNER.—J. W. ALBIN, Babylon, N. Y. The mechanism is adapted to support sheet music on a musical instrument and successively turn the sheets. The mechanism also serves to return all the sheets simultaneously to their original position so as to permit the piece to be played over again.

ATTACHMENT FOR TALKING MACHINES.—C. MARTELOCK, Oroville, Cal. The particular object of this invention is to provide an attachment for a machine known commercially as the B. C. graphophone. The attachment is designed to increase the delicacy of adjustment between the record and the stylus needle and also to increase the general efficiency of the apparatus.

WASHING MACHINE.—T. C. SØRENSEN, Copenhagen, Denmark. The invention provides an arrangement in connection with washing machines of the kind that consists of a firm casing containing the washing solution, within which revolves a perforated drum provided with buckets on its outer surface into which

drum the clothes to be washed are placed. The buckets are formed by means of curved plates extending the whole length of the drum and at a certain distance from the same and connected to the drum by means of radial plates.

CONCENTRATOR.—R. H. MANLEY, Stockton, Cal. The object of the invention is to provide a concentrator for separating heavy materials from lighter ones, such as gold from sand, or extraneous matter. The device is arranged to allow of effectively treating a large quantity of material in a comparatively short time with or without the use of water.

TAKE-UP FOR LOOMS.—B. WEHLEN and F. C. MATTHEWS, Pompton Lakes, N. J. The device serves to draw fabric such as a ribbon from the loom, and it is practically impossible to release the fabric from this device owing to its novel construction, hence the possibility of slackening the warp with the danger of interfering with the operation of the weaving is obviated. The take-up leaves the front of the loom entirely free and unobstructed and does away with the cumbersome wooden frame usually employed.

DIGESTER.—C. EDGERTON, Philadelphia, Pa. The invention relates to digesters of the type in which an outer containing vessel is provided interiorly with a rotating perforated receiver suspended within the outer receiver by means of trunnions, and provided with gears for rotation within the stationary container. The invention relates particularly to a novel construction of receiver and container, such as will facilitate the discharge of both solid and liquid matters.

APPARATUS FOR TESTING FLUID METERS.—T. B. DORNIN, Norfolk, Va. In the operation of testing water meters, it is necessary to temporarily couple up the inflow and outflow nipples to a supply pipe so that the supply water flowing through the meter will register on the dial and then discharge into a measuring tank where the volume of water is compared with the registration on the dial. The present invention provides a simple construction whereby a large number of meters may be simultaneously connected with tight joints to the supply pipe, so that all the meters may be tested at once. Mr. Dornin has also obtained a patent on another construction which performs the same office of permitting a number of meters to be tested at the same time.

HAND SCHOOL-LOOM.—BEATRICE E. LINDBERG, Faribault, Minn. The invention relates to kindergarten looms and is an improvement upon previous patents by the same inventor. The present improvement consists in arranging the loom to permit the weaver to conveniently open and change the shed for the passage of the shuttle or needle used for carrying the weft through the open shed.

WOOD-BORING MACHINE GUARD.—E. R. KING, Memphis, Tenn. Operators of wood-boring machines are frequently injured or their clothing is torn by contact with the rotating heads, or clamping screws of the boring bits. To prevent such accidents, Mr. King has devised a skeleton guard which entirely incloses the bit proper and the rotating spindle head.

Prime Movers and Their Accessories.

LUBRICATOR.—J. NOETHE, Elkton, South Dakota. This lubricator is of the four-speed type adapted for use on engines and is so constructed that when the engine is started a pressure is placed on the oil in the reservoir and the oil is mechanically forced through a suitable pipe into the steam chest or other portion of the engine requiring lubrication.

WAVE MOTOR.—R. CRAIG, Los Angeles, Cal. This motor is adapted to be operated by the rise and fall of waves of the sea. The invention provides novel details of construction adapted to effect the positive and continuous conversion of the force of the waves during their rise and fall into a rotary motion of a driven-shaft for the actuation of other mechanism.

Railways and Their Accessories.

CAR WHEEL.—T. M. CREPAR, Fargo, North Dakota. The object of the invention is to provide a simple, strong and inexpensive car wheel, adapted to be mounted with another similar wheel rigidly upon a car axle and having means for permitting the independent movement of each wheel rim in rounding curves. The hub section is made rigid with the axle, while the rim is movable relatively thereto, bearing balls or rollers being interposed between the sections.

HEATING FURNACE.—W. N. BEST, New York, N. Y. This furnace is adapted particularly for heating railroad tires or other bodies, and comprises an improved wall structure for the furnace with means for delivering the heating medium to the interior thereof. The inlet through which the hot gases from the burner pass into the furnace is constructed to give a uniform distribution of heat.

RAILROAD TIE.—R. L. BOWER, Blandburg, Pa. The invention provides a metallic tie arranged to prevent movement of the tie in the direction of its length, that is, transversely to the roadbed, thus rendering the tie eminently useful on curves and other places subjected to great force by passage of heavily loaded or fast trains.

MEANS FOR CONNECTING PARALLEL RAILROAD RAILS.—V. A. WHITE, Aliceville, Ala. The invention provides means for connecting the parallel rails of railroad tracks whereby they are held rigidly spaced apart at the required distance, so that separation of the rails is impossible. The invention also includes means for connecting the meeting ends of railroad rails and holding them in rigid alignment.

CAR STAKE.—N. E. GAGNON, Woodland, Wash. This car stake belongs to that class of stakes adapted for application at each side of a flat car on which logs are loaded. The improved stake is arranged to be applied to the sockets generally found at the side of such cars, or it can be fastened thereto in various other ways.

Of General Interest.

LUBRICATING CUP.—C. STEWART, New York. This oil cup is of air-tight construction with an outlet below the normal liquid level, and is provided with an air inlet which may be adjusted to control the admission of air so as to govern the flow of lubricant through the outlet.

HARNESS BUCKLE.—L. L. ROUNDS, Orange, N. J. The purpose of the invention is to provide a harness buckle, more especially adapted for use on a saddle girth, and arranged to permit a rider to pull the saddle girth tighter without dismounting. Means are also provided to prevent the buckle from opening accidentally.

FIRE-NOZZLE ATTACHMENT FOR VALVES.—J. D. SCHIERLOH, Jersey City, N. J. A combined faucet and fire nozzle is provided by this invention. The handle of the faucet is fitted with a nozzle which may be rotated thereon and the handle also may be rotated on its axis to direct the stream issuing from the nozzle to all portions of the room or compartment. By means of a set screw the handle may be released from engagement with the stem of the faucet valve and the water will then flow through the handle and out of the fire nozzle.

ADVERTISING APPARATUS.—J. REIX, 33 Boulevard des Batignolles, Paris, France. The invention consists in providing a pair of parallel wires which may extend around the house or on the front of a building. Suspended from these wires, which receive current from a source of electricity, is a carriage provided with a motor which causes it to travel along the wires, and a procession of luminous letters which are also suspended from the wires are connected to the motor carriage.

FOUNTAIN BRUSH.—H. KADUSHIN, New Rochelle, N. Y. This fountain brush is designed to contain an acid or other cleansing liquid to permit of using the brush for cleaning type, textile fabrics, and other articles and materials. A special form of slide valve is provided which controls the flow of the acid to the bristles.

IMMERSION REGULATOR PARTICULARLY ADAPTED FOR TORPEDOES.—A. E. JONES, Fiume, Austria-Hungary. The invention has for its object to improve the immersion regulators used on self-propelled torpedoes in which the combined action of a hydrostatic piston and a pendulum is employed. The invention relates particularly to diminishing certain resistances at the joints, thus assuring the operation of the device under all conditions.

FLOWER STAKE.—W. HENSHAW, Springfield, N. J. This stake or support is adjustable to suit plants of different sizes and has a special construction facilitating the attachment of the stake to supporting wires such as are used by florists for holding the plants in an upright position when they are being sprayed.

BOTTLE.—J. A. GAFFNEY, Brooklyn, N. Y. The bottle belongs to that class of non-refillable bottles in which a loose grooved stopper is held in the bottle neck in such manner as to permit outflow of liquid when the bottle is inverted, but which normally seats downward in such position as to prevent ingress of liquid.

FASTENER.—L. F. HAMMER, Omaha, Neb. This fastener is adapted for use on fences, cribs, or the like, for removably supporting cross boards, panels, etc., in position. The fastener is rotatably mounted on its support and may quickly be moved to such position as to permit the removal of any one of the cross boards without deranging those remaining in place.

CHAPLET AND SHRINE OF THE HOLY ROSARY.—W. HENDRICK, New Haven, Conn. The object of this invention is to provide an improved chaplet and shrine of the Holy Rosary arranged to successively display pictures of a religious character, one at a time, and in proper order, according to the intended devotional exercise.

APPLIANCE FOR RELEASING BOATS.—C. L. BEVINS, Jamestown, R. I. Mr. Bevins has invented an improvement in appliances for releasing boats, especially lifeboats from the davits of vessels, docks, and other elevated places. The invention provides means operable to simultaneously disconnect both the bow and the stern of the boat whereby the danger of launching is materially diminished.

WATCH.—J. T. PENDLEBURY, 12 Thornley Brow, Manchester, England. The invention relates to dust cover for the movements of watches and provides a simple and efficient

dust-proof cover which will permit the regulator to be altered without removing the cover. The cover is preferably made of celluloid.

NOTE.—Copies of any of these patents will be furnished by Munn & Co. for ten cents each. Please state the name of the patentee, title of the invention, and date of this paper.



Full hints to correspondents were printed at the head of this column in the issue of August 8th, or will be sent by mail on request.

(10888) J. L. M. asks: What is the most practical and least expensive process to produce, as near as possible, an absolute vacuum in a chamber containing about four cubic feet? Will it require a greater capacity of power to empty a large space than it will a smaller one? A. To exhaust so large a space it will be necessary to use a mechanical air pump. It is not possible to produce an absolute vacuum by any means of exhaustion. It will, however, not require any greater power to empty a large reservoir. It will require more time.

(10889) E. V. V. writes: I have had some little trouble in convincing a man that ice forms on the bottom of a running stream of water, but having seen the same I know I am right. Would you kindly answer same in your valuable paper? A. Anchor ice is often to be seen fastened to the stones on the bottom of a stream, and also to the timbers around a mill. Very frequently mills are stopped by the anchor ice during a very cold snap.

(10890) B. H. G. asks: Please inform me through your Notes and Queries the principle and details of the radiometer? A. The radiometer is a heat instrument. Light has no connection with it. It consists of a glass globe, usually about two inches in diameter, exhausted to a suitable degree. Within is a steel pivot upon which revolves a cross arm carrying four vanes of aluminium, one face of which is blackened by carbon. When heat falls upon the vanes the black faces absorb more than the bright and are hotter. The molecules of air coming in contact with the black faces are heated more than those coming in contact with the bright faces and rebound with more force. The reaction of this rebound causes the vanes to revolve with their black faces in the rear. The globe itself has been made to show a tendency to rotate in the opposite direction to the vanes, this being due to the bombardment of the inner surface of the glass by the stream of molecules which rebound from the vanes. Thus the radiometer is a heat engine, transferring heat from the black side of the vanes to the surface of the glass opposite. A satisfactory explanation of the phenomenon is given in Barker's "Physics," price \$3.75 by mail. See also SUPPLEMENTS 13, 37, price ten cents each. 2. Please state also whether energy exists in light; and to what extent. A. Light and heat are now classed together as radiant energy by scientists, and the energy of both is measured by absorbing some material and determining the heating effect it produces. The energy of light as light has not been measured by any mechanical effect which it can produce.

(10891) C. M. A. asks for information concerning sodium silicate. A. Silicate of soda (or soluble glass) is prepared by fusing together carbonate of soda and sand, or by boiling flints in caustic soda under great pressure. It is not soluble in cold water, but dissolves in five or six times its weight of boiling water. It is employed in the manufacture of soap, in fixing colors, in preserving stones from decay. In admixture with other silicates, silicate of soda occurs in glass; and it (equally with silicate of potassa) imparts the property of viscosity before fusion to such mixtures, which is of great value in the working of glass.

(10892) J. N. P. says: 1. Why and how does water put out fire? Why does the water have the same effect whether hot or cold? A. Water puts out a fire by reducing the temperature of a flame below the point of ignition, and is especially efficient for this purpose because of the large amount of heat that is required to turn it into steam. It is almost as effective when hot as when cold, because of the great amount of latent heat in the water. 2. Does the sun shining directly on a cooking stove have any effect upon the cooking? Does it lessen the baking in any way? If when shining on a fire in an open grate, does it reduce the heat? A. The sun shining directly on a stove or fire in an open grate tends to increase the temperature slightly, just as it tends to increase the temperature of any other object. The bright sunlight, however, may make the fire appear less brilliant, and therefore appear to give out less heat. This effect, however, is deceptive.

(10893) W. B. H. writes: I was given a question in a recent examination that the examiner stated was proved in a copy of your magazine; but he could not state the date the example appeared nor prove it himself. The

problem read: "Do the amperes or volts increase when the electricity passes through an ordinary spark coil for gas lighting?" I said volts, yet my examiner says the answer is amperes, which I doubt. A. The volts are raised in the action of the ordinary spark coil in gas lighting. This coil has but one winding, no secondary. It is not an induction coil in the usual sense. The spark is produced by the self-induction of the current in the turns of the primary upon itself. This produces a higher E. M. F., which causes a considerable spark. There can be no more amperes in the circuit than the generator can produce.

(10894) W. A. P. asks: 1. Should an ampere-meter be placed in the positive or negative terminal of a direct-current 110-volt dynamo? A. The ammeter may be placed at any point whatever in an electric circuit, since the same current flows through every part of a circuit. This is just like the flow of water through a pipe. If you had a pipe 1,000 feet long from a reservoir to your house, the same water and just as much would flow through every foot of the pipe, and a meter might be put into the pipe at any point in its length and the quantity of water flowing through the meter to be measured. 2. How much more would it register in the former than in the latter? A. It would register the same in either side of the circuit. It makes no difference where the ammeter is placed.

(10895) A. E. S. says: May I ask you to kindly inform what chemical changes take place during the setting of Portland cement, plaster of Paris, and similar substances. A. Mortar, which is made of slaked lime and sand, when exposed to the air, slowly changes into carbonate of calcium, and the entire mass becomes extremely hard. The water contained in the mortar soon passes off. When limestones that contain magnesium carbonate and aluminium silicate in considerable quantities are heated for the preparation of lime, the product does not act with water as calcium oxide does, and this lime is not adapted to the preparation of ordinary mortar. On the other hand, it gradually becomes solid, in contact with water, for reasons which are not known. Such substances are known as cements. Plaster of Paris is found in nature in the form of gypsum or anhydrite, and consists of calcium sulphate and water. A granular form of gypsum is called alabaster. Calcium sulphate is difficultly soluble in hot and cold water. When heated to 100 deg. Cent. or a little above, it loses all of its water and forms the powder known as plaster of Paris, which has the power of taking up water and forming a solid substance. The hardening is a chemical process, and is caused by the combination of the water with the salt to form a crystallized variety of calcium sulphate.

(10896) H. H. M. says: Would you kindly inform me if I could get an object to float that is heavier than the water it displaces? For instance, are these large ocean steamers heavier than the water they displace? A. If a rigid body or solid be immersed in a liquid, both being at rest, the resultant action upon it of the surrounding liquid is a vertical upward force called the "buoyant effort," equal in amount to the weight of the liquid displaced, and acting through the center of gravity of the volume of displacement. From this it will be readily seen that you cannot secure an object to float which is heavier than the water it displaces. In the case of the vessel, because of the particular form of the hull, the law of displacement remains the same. The weight of the water displaced by the hull equals the entire weight of the ship and its cargo.

(10897) G. J. R. asks: Can you give me the reason for the vibration in a motor or generator when the armature and shaft are balanced as nearly as possible? I would like to see what your opinion is in regard to it. A. The slightest excess of weight on one side will cause a perceptible vibration of an armature. As little as one-thousandth of the total weight will cause a very considerable vibration. If an armature is perfectly balanced, it will run so quietly that it is difficult to tell whether it is in motion or not. The process of balancing an armature is described in Crocker's "Electric Lighting," Vol. I, price \$3 by mail.

(10898) G. H. E. writes: In an informal conversation the statement was made that of the energy stored in a given amount of coal an extremely large proportion is lost in the attempt to employ it productively, as in the steam engine, and that the utilization of the energy wasted by the present methods is an important scientific and economic problem. This statement was challenged, and in the resulting discussion the following questions arose. 1. How large a proportion of energy stored in a given amount of coal is lost by methods commonly in use? A. From 20 to 25 per cent, and sometimes more, of the heat value of the coal is now lost. 2. At what stages in the process of transformation, and how, do the chief losses occur? A. Mostly by the heat going up the chimney, and to a small degree by bad stoking and radiation of heat from defective insulation of boiler setting and pipes. 3. What percentage of the energy in a given amount of coal can be (not is) used in producing steam? A. The possibilities for utilizing the full energy of coal are very small. Little may be expected over the best practice of to-day. It is the converting of the

steam into active power wherein the trouble lies. 4. How is the amount of energy in a given amount of coal ascertained? A. The absolute amount of energy in coal is found, first by an analysis of its combustible constituents, from which the heat units are computed; second, by actual combustion of a given weight and measuring its heat producing property by absorption of the heat in water or by melting ice in a calorimeter.

(10899) J. A. M. writes: Will you kindly inform me whether the following facts are new, or only so to the writer? The mechanical equivalent of heat as given by Dr. Joule's experiment of a weight falling through air, actuating thereby wings in water, is 778 foot-pounds according to William Kent. Now you will note that the relative weights of water and air are as 1 to 774. Is there not an equation here between work, water, heat and air? Might not the slight variation of 774 and 778 pounds be due to the slip of the water? William Ripper gives the equivalent as 772 pounds. A. The mechanical equivalent of heat, which is called Joule's equivalent, as determined by Dr. Joule, was 772 foot-pounds. That is, to lift 772 pounds to a height of 1 foot requires the same amount of work as to heat 1 pound of water 1 deg. Fahr. This work was done between 1840 and 1843. Considering the condition of mechanical science at that time it was a marvelous piece of work. He employed the friction of water and measured the heat produced. Joule also determined the equivalent by means of the electric current. Others investigated the same constant by other methods, the compression of metals, the specific heat of air, the induced electric current in metals, and the velocity of sound, with results fairly in agreement with that of Joule. Joule's method was that of direct determination of the number of foot-pounds of work used in actually heating one pound of water one degree. Other methods were indirect. That these coincided fairly well with the direct method was all that could be expected. All methods are open to errors, and more or less close approximations are all that could be attained. In 1879 Prof. Rowland took up the problem with the finest appliances of modern science. He employed water friction, as did Dr. Joule. His results were immediately accepted. Probably the work will not be done over again for a generation. Some of his results involved as many as 12,000 distinct observations. He proved that the mechanical equivalent varies with the temperature. Between 41 deg. and 68 deg. there is a change of nearly eight-tenths of one per cent in the latitude of Baltimore. The mean of Prof. Rowland's results is 778 foot-pounds, which for all ordinary purposes is at present considered the true equivalent. Prof. Rowland's experiments showed that the specific heat of water diminishes from 32 deg. to 84 deg., and then increases till the boiling point is reached. Rowland was able to produce a change of 63 deg. in the water where Joule could produce a change of only 1 deg. He also used the sensitive air thermometer instead of the slow mercurial thermometer.

(10900) J. C. A. asks: Please inform me how to make a strong magnet of Jessop steel. I have tried to make some 1/2 inch square by 3 inches long, straight bars, by passing them through a spool of wire with a 300-volt current, by which they were strongly magnetized, but lost almost all magnetism in about three weeks. How can I make such magnets which will retain their strength for a long time? A. Heat the bars to be magnetized to a red heat and plunge them into water. They are then to be magnetized. Straight bars do not retain magnetism well. They should lie in pairs with opposite poles toward each other, side by side, not end to end, or else in pairs with an iron keeper across the poles. They may be laid four in a square with opposite poles against each other. Laid down alone without keepers, the magnetism is rapidly lost.

(10901) W. F. G. asks: Will vulcanized fiber answer for the insulation on static machines, and are vulcanite and vulcanized fibers identical? A. Vulcanized fibers will be but little better than wood as an insulator in this position. Vulcanite is hard rubber and is a different substance from fiber.

(10902) E. L. asks: 1. Can you tell me, without knowing the amperage, the voltage being 50 volts, if a 75-watt dynamo or 1-6 horse power as motor will light 5 lamps of 10 candle power at full capacity? A. Ten-candle lamps may be taken to be from 3 watts to 4 watts per candle. One lamp will consume from 30 watts to 40 watts, and 75 watts will light two such lamps. 2. What is the resistance of No. 16 iron wire? A. Pure iron has a resistance of 6 times as great as copper. Ordinary telegraph wire has a resistance 15 times as great as that of copper of the same size. No. 16 copper wire has 248.81 feet per ohm. Pure iron wire of the same size would have 41.47 feet per ohm, and No. 16 ordinary iron wire would have 16.19 feet per ohm. 3. If a current of 10 amperes at 108 volts goes through 540 feet of No. 16 iron wire, what will be the electromotive force and current remaining after it has gone through, and how to calculate it? A. There will be 10 amperes remaining. But there will not be any volts remaining, if the wire constitutes the entire circuit between the mains. The same amperes flow through the entire circuit and come out at the other end, just as the water

flows through the entire length out of a pipe open at both ends and comes out at the other end. The drop of potential along a wire is proportional to its length, provided it is of uniform sectional area, as it may be presumed to be in this case. This being so, there will be a drop of one volt for each four feet along the wire. 4. Can we run a direct-current motor with an alternating current? The motor is not loaded. A. Yes; if it be started and brought up to synchronism with the current by hand, or by some other power. It will then keep step, and run by alternating current.

(10903) E. B. asks: 1. I want to magnetize an ordinary twist drill, making a magnet of it. Will I have to draw the temper of the drill first, or can I make a magnet of it as it is? A. The cutting end is already hard enough for your purpose. Heat the other end to redness and plunge into water, then magnetize. 2. How many amperes of current will it take to magnetize it by means of a coil of 6 or 8 layers of No. 18 silk-covered wire, the current being 110 volts? A. You must be governed by the heating of your coil. Use only so much current as will not heat the coil so that the insulation burns. That would destroy the coil. 3. In making a permanent magnet of tool steel, shall I first soften the steel before magnetizing it, or should it be hardened at the ends? A. Harden the bar at the ends glass hard.

(10904) E. S. D., Jr., writes: 1. I would like to know if you could give me the formula for a solution for bichromate cells, with a good ampere output, in the right proportions, and how to mix it, etc.? A. A good solution may be made after the method described in SUPPLEMENT No. 792, price ten cents. 2. Which is the best form of bichromate to use for making electropoison fluid—the sodium or the potassium? A. The sodium salt is easier of use. 3. What is the best way of amalgamating a zinc? A. The usual method is to clean the plate with dilute sulphuric acid, and then rub mercury over the plate, dipping it into the dilute acid if necessary to make the mercury take to the surface. 4. I would like to know if I could have a battery rheostat made for these batteries, steady current, etc.? A. Yes; though there is little need of one. The amount of current can be regulated by immersing the zincs to a greater or less depth in the liquid.

(10905) A. B. McK. asks: Will you kindly give me what information you can on the following subject? Take a piece of steel and cut in two pieces. Make one as soft as possible and the other as hard as possible; now, what will be the difference in resistance in ohms, if any? A. Barus and Strouhal give the specific resistance of glass-hard steel as 45.7 and of soft steel at the same temperature as 15.9. This is the resistance in thousandths ohms of a bar one square centimeter in cross section.

(10906) C. W. asks: Please inform me as to the difference between an aneroid and a holosteric barometer. A. The word *aneroid* is from two Greek words meaning without liquid, and the word *holosteric* is from two Greek words meaning wholly solid. They are two names for the same thing. There is no difference between them.

(10907) G. M. D. asks: What should be the dimensions, size and amount of wire for a 12-inch coil, 15-inch coil and 18-inch coil? Is there any definite relation existing whereby the above information may be determined from a known coil? A. The dimensions of induction coils are the result of experience rather than of calculation. The properties of the magnetic circuit and the effects of induction are well known, and can be applied to an induction for giving sparks; but almost every builder works from designs which have been wrought out by experiment and are known to give good results. The sizes and windings of certain large coils are given in Hare's "Large Induction Coils," price \$2.50 by mail.

(10908) F. J. B. asks: I would thank you if you would treat upon the hardening of copper and aluminium, and if the discoverer of same would be amply rewarded. A. There is a very old belief that the ancients knew how to temper copper as we temper steel. No tempered copper is in existence, and there are scholars who do not believe it ever was done. We doubt very much whether there would be a wide use for hardened copper or aluminium, unless their tensile strength could be greatly increased by the process. We have assisted in making experiments to this end, but without success. If aluminium could be made as strong as iron, there would be a great market for the wire for electrical purposes.

(10909) J. J. S. asks: 1. In making Leyden jars, I have had great difficulty in coating the inside with tinfoil. Will you kindly advise me on the following points: Would it do equally well to half fill the jar with tinsel, of course coating the outside with tinfoil? A. No. The tinsel will not be continuous, nor will it be in contact with the sides of the jar. 2. Would it do to shellac the inside up to the proper height and shake in bronze powder? A. Not so well as tinfoil. 3. In using tinfoil, should the bottom, inside and outside, be covered? A. Yes. There is not much difficulty in placing the tinfoil properly in the jar. Cut the foil into strips of two inches or thereabout in width. Apply the paste to the inside of the jar with a long-handled brush. Put the foil

in with forceps or in any other convenient manner, and bring it to its place and rub it down with a dry brush with long bristles. 4. I have made a Wimshurst machine with 18-inch plates, but can only get a spark of 3/4 inch. Is this all a machine of that size is capable of, or have I made some mistake in construction? A. The spark is not long when a Leyden jar is not used. And indeed when the jar is used, its effect is to render the discharge intense rather than to lengthen the spark.

(10910) M. O. C. asks: Can you inform us how to copper common iron castings without a battery so they will not rust, or how to whiten them by dipping? A. To copper iron castings, the articles must be made perfectly clean, and then dipped in a solution of 1 1/2 pounds copper sulphate in water, to which 1 ounce sulphuric acid has been added. They are then washed and dried.

(10911) W. H. asks: Please give me the best formula for a dry primary battery. A. One of the best dry cells is said to be filled with the following mixture: Oxide of zinc, 1 part by weight; sal-ammoniac, 1 part; plaster of Paris, 3 parts; chloride of zinc, 1 part; water, 2 parts.

(10912) F. J. R. says: Hearing there is a certain tree which grows in salt water, please give me the name of said tree. A. There are a number of trees which will grow in salt water, of which perhaps the best known is the mangrove. There are many places in the tropics, notably in Papua, Borneo, Java, and other East Indian islands, where for miles there is no "coast" in the ordinary sense of the word, vegetation being reached directly from the ocean some distance, often miles, before solid ground is reached, forests of mangroves growing out of the shallowing sea, between which it is possible to cruise in small boats by innumerable sheltered waterways, locally known as "trusuns," among the mangrove stems and roots.

(10913) A. G. asks: Kindly advise where I can procure the formula for calculating the horse-power of a 4-cylinder 4-cycle gasoline engine, cylinder 5 1/4 x 6 inches, 400 revolutions per minute. This is for marine engines. I need a certain power for an experiment I am trying, and find considerable difficulty in getting reliable data. A. There is no difference between the formula for calculating gas engine horse-power and that for steam en-

gines, namely, horse-power = $\frac{p \cdot l \cdot a \cdot n}{33,000}$ in which p = the mean effective pressure, l = the length of the stroke in feet, a = the area of the piston in square inches, and n = the number of effective strokes. The last-mentioned point is the only one in which a mistake is likely to be made. Whereas in an ordinary double-acting steam engine (with steam acting on both sides of the piston) the number of effective strokes is double the number of revolutions, in a 4-cycle gasoline engine taking gas only on one side of the piston there is only one effective stroke in four, i. e., the number of effective strokes is half the number of revolutions. There is more difference between indicated and brake horse-power in gas and gasoline than in steam engines, because in the latter the difference is only friction of the parts, whereas in the former it includes overcoming the inertia in the inspiration and exhaust strokes and compression of the gas.

(10914) E. H. A. writes: All text books on physics will state that action and reaction are equal. Yet reaction applied records more failure than success. Branca's turbine, the little twirly-twirly sprinkler in the yard, reaction ship propulsion, have all proved that reaction is not equal to action. The Pelton wheel is efficient because it is an action wheel mainly. The only record of a reaction device being a success is the Avery steam turbine, an American invention. However, it seems to have been short-lived. Of course, you stand ready to affirm that action and reaction are equal. Could you then shed some light on the weakness of all reaction? A. We regret that we are unable to take your view of the law of action and reaction. Perhaps the other form of statement might be plainer: "The mutual actions between two bodies are equal and opposite in direction." The meaning of the statement is that a force exerted on any body is exerted by some other body, and this other body experiences an equal and opposite force to that it exerts upon the body against which it acts. A bat strikes a ball. The bat loses the amount of momentum which it gives to the ball. In other words, the ball reacts against the bat to the same amount as the bat acts upon the ball. This satisfies us, and it has satisfied mathematical calculations of forces and their effects for a very long time. We are unwilling to give it up till its place can be supplied with a principle better than this.

(10915) C. A. S. writes: Referring to query 10860, SCIENTIFIC AMERICAN, September 26, 1908, will you allow me to suggest that the term "weight" is the source of much misunderstanding, as it is indiscriminately used in two senses? Generally and commercially, the "weight" of a substance is simply a measure of the quantity of matter in the object weighed. In this sense it is always the same when weighed on the ordinary commercial scales, whether on, above, or under the surface of the earth. When "weight" is used in place

of "force of gravity," then it varies with the altitude, as explained in the above query, because, in that sense, it is altogether a different thing. Generally speaking, the lever scale is a matter-measuring machine, and the spring balance is a force-measuring machine. The amount of matter as on a high mountain as determined by the lever scales; but the pull of the force of gravity on that same body is less on the mountain than it is on the surface of the earth, as determined by a spring balance (a force-measuring machine, or dynamometer). A. We are not able to agree with your use of the word "weight" in two senses. The textbooks all use the word in the sense of "measure of the force of gravity." We do not know any other scientific sense of the word. Mass is universally employed for "quantity of matter," which, as you say, is invariable. The distinction might be made as you give it, but it is not in the scientific world and in the textbooks which our youth study, and it would take too long to introduce it. The game is not worth the candle. We had better continue to say mass when we mean mass, and weight when we mean weight.

(10916) H. C. E. asks: In the experiment "to measure the velocity of sound by a resonance tube," we add to one-quarter the wave length or the length of the resonant tube, a fractional part of the diameter, which correction Lord Rayleigh gives as one-half. Will you tell me why the diameter affects the experiment and necessitates this correction? A. The fact that a pipe is not an exact fraction of the wave length of its fundamental tone is determined by experiment, and the fractional part of the diameter or radius to be added as a correction can then be determined. It is true that the calculations are not exact, and the allowance for the "end correction" is not entirely satisfactory. It is to be taken as nearer 0.6 than 0.5 of the diameter. The reason is found in the reflection of the waves from the yielding air at the open end of the pipe. This has the effect to move the node farther out beyond the end of the pipe. This effect is greater in a large pipe than in a small one, since there is a broader surface of air over the open end than in a small pipe. It is simple, then, to make the end correction depend upon the diameter of the pipe. This is discussed at some length in Poynting and Thompson's "Text Book of Physics," Sound, pages 104 to 108.

(10917) R. F. K. asks: Is there any substance that can be interposed between a horseshoe magnet and a piece of steel that will prevent the attraction of one for the other? A. There is no substance which can be interposed between a magnet and a piece of steel to cut off the action of the magnet upon the steel, excepting a heavy piece of iron, heavy enough to furnish an easy path for the lines of force of the magnet. They will then take the path through the iron, and will not reach the piece of steel farther away. Magnetism cannot be insulated as electricity can.

(10918) C. S. says: Which color on a window curtain will be the most effective in keeping out heat from the direct rays of the sun? A. White is supposed to be the coolest color, that is, to keep out the most of the heat of the sun, and therefore to be coolest for clothing and curtains.

(10919) D. O. V. says: Suppose we have a 3-phase, 60-cycle, 220-volt alternating-current motor on a constant load. We apply 220 volts at the terminals, and the motor carries the load on 10 amperes of current. Now suppose we apply 440 volts at the terminals, how many amperes will the motor draw? What will be the result? Will the amperage be higher or lower than in the first case? A. If you should apply 440 volts at the terminals of a motor wound for 220 volts, the result would be that you would have to call out the fire department, and lose the machine if the fuses did not blow. It would cause a burn-out. Consider Ohm's law: Amperes equal volts divided by ohms. With an alternating current you must also introduce the induction and reactance as increasing the resistance and reducing the amperes, but if you double the volts you must of necessity greatly increase the amperes. With a direct current, doubling the volts doubles the amperes, the resistance being the same. A good book from which to learn the characteristics of electric currents and machines is Sloane's "Handy Book," which we send for \$3.50. It should be in every electrician's library.

(10920) J. W. B. says: I have been reading your paper for several years, and have found your answers to correspondents to be all right, except I wish to disagree with you in your answer to query 10826, in which you state that to make ground connection with the steel cresting with heavy telegraph galvanized wire would be as good a protection against lightning as could be had. Now, in the first place, you know as well as I do that copper is a better conductor for electricity than steel or iron, so I claim that the only real way to protect from lightning is to properly rod the building with a pure copper lightning rod, putting it on in one continuous piece of cable and erecting pure copper joints not less than 5 feet long nor over 24 feet apart, nor over six taps to two ground connections. I have seen buildings badly damaged by lightning that were protected just as you recommend in 10826 answer. Also I have seen telephone poles split all to pieces that had a galvanized wire grounded and run 5 inches

above top of pole. So if a wire of that sort would not protect a little telephone pole, what good would it do on house or barn? A. We regret that you are unable to agree with our note upon the use of heavy galvanized wire as a lightning rod, and that we also find ourselves unable to agree with your idea of a suitable lightning rod, the tall copper rod with points raised several feet above the roof. We are minded to present a somewhat full discussion of these points from the standpoint of the most recent articles by authorities upon the matter. As to points upon the rod, we quote Dr. Neesen of Berlin, Germany, in SUPPLEMENT 1503. Describing the failure of points to discharge a Leyden jar, he says: "If the small charge of a Leyden jar cannot escape during the approach of the cup, the immensely greater discharges of the air can surely not be dissipated in this way. Millions on millions of points, like the leaves and twigs of a forest, are needed. But even in a forest it happens that a single tree is struck by lightning. Conductors without points can draw the discharge to themselves from other parts of the building. In recognition of this fact, intelligent makers of lightning protectors have discarded the points of platinum, carbon, etc., once so highly esteemed." This we published in 1904. Perhaps it escaped your notice. Later in the same article the professor describes the network of wires as the most efficient means of protecting oil tanks and powder mills, and approves the use of metal ridge plates, roofs, gutters, and leaders, although the danger of air gaps in such parts of a building would render the reliance upon these rather doubtful. Turning now to some English authorities, Maxwell proposed to cover the house with a network of wires, making it in effect a Faraday's cage for protection from lightning. That so complete isolation is not a necessity in our country would prevent the use of this method here. Prof. Silvanus P. Thompson and Sir Oliver Lodge, both of the highest authority, agree that iron is to be preferred to copper. Their rules are to be found in Thompson's "Electricity and Magnetism," page 320, price \$1.50. We quote for you the principal points, although we printed them in full not many years ago in the SCIENTIFIC AMERICAN: "1. All parts of a lightning conductor should be of the same metal, avoiding joints, and with as few sharp bends or corners as may be. 2. The use of copper for lightning rods is a needless extravagance. Iron is far better. Ribbon is slightly better than round rod; but ordinary galvanized iron telegraph wire is good enough. 3. The conductor should terminate not merely at the highest point of a building, but be carried to all high points. It is unwise to erect very tall pointed rods projecting several feet above the roof. 4. A good deep wet earth should be provided, independent of gas or water pipes. 5. Connect gas and water pipes metallically. 6. Insulate the conductor away from the walls, so as to lessen the liability to lateral discharge to metal stoves and things inside the house. 7. Connect all external metal work, zinc spouts, iron crest ornaments, to each other and to the earth, but not to the lightning conductor. 8. The cheapest way to protect an ordinary house is to run common galvanized iron telegraph wire up all the corners, along all the ridges and eaves, and over all the chimneys; taking them down to the earth in several places, to a moist stratum, and at each place burying a load of coke. 9. Over the tops of all chimneys it is well to place a loop or arch of the lightning conductor made of any stout and durable metal." We may use for an American authority Prof. Carhart of the University of Michigan, of whom you doubtless know. We quote from his textbook, "University Physics," vol. 2, page 229, of the latest revision, price \$1.75. He says: "The revision of theory and the results of experiment have left much of former recommendations relating to lightning rods of doubtful value. For the condition of steady strain pointed conductors are still advisable; but it is not necessary to provide the elaborate terminals formerly deemed essential. Nor is a copper conductor of large section necessary or desirable. It is far better to provide a number of paths for the discharge down several different parts of the building, each consisting of a large galvanized-iron wire sharpened at the top, avoiding short bends and loops, and ending in a mass of iron or charcoal buried in moist earth. Such a conductor may be fastened directly to the building without insulators. It is probable that No. 4 or 6 iron wire, B.S.G., will safely carry off any discharge that is likely to traverse it. The writer has known a much smaller iron wire to conduct safely a discharge which converted smaller copper wire into vapor. Tall chimneys may be adequately protected by three or four iron wires ranged around the outside, not placed together, but connected at frequent intervals, and all well grounded." We have quoted thus at length so as to place within your reach opinions to which you may not have access, although if you have your file of the SCIENTIFIC AMERICAN and the SUPPLEMENT you have all and much more at your hand if you search it out. The only basis of preference for copper is its durability, freedom from corrosion near gases from chimneys, as compared with iron. It has no electrical advantage over iron. Its greater cost renders it less desirable than iron. It is rarely a question of electrical resistance. Benjamin Franklin long ago noted the leaving of a good conductor by the flash to take a small wire or a streak of gilt metal on a wall paper, having an enormous resistance, relatively. Some other reason must be sought. It is found in this: There are different kinds of electrical discharges, in only

one of which is resistance of any account. If the cloud rises steadily in intensity and induces a similar quiet condition of charge in the earth below, and by the cloud and the earth will equalize, by a lightning discharge, and the strain will be relieved. Such a discharge will follow a conductor almost as well as a battery current. Such discharges are not uncommon. Lightning rods carry these off safely, and the copper rod you describe will do it well. But so will the iron wire just as well. A frequent discharge is of another sort. It is called the impulsive rush. To quote Prof. Carhart, page 228: "In this case the electric pressure is developed with such impulsive suddenness that the dielectric (the air) appears to be as liable to break down at one point as at another. Such sudden rushes are liable to occur when two clouds spark into each other and then one overflows into the earth. [You may have seen this.] The highest and best conducting points are then struck irrespective of points and terminals. The conditions determining the path of the discharge in the case of these impulsive rushes are entirely different from those of the steady strain, and points are incompetent to afford protection by preventing them." This last condition describes exactly the case of the telephone pole which you have seen struck when it had a guard wire. It is found not infrequently in the long transmission lines of the West, especially in mountainous regions, and constitutes the greatest danger from lightning. Against it no rod is effective, and the heavy copper or even iron rod, some of which we have seen put up an inch thick, is entirely worthless. Finer wires are better in this case, although not a safeguard, since if struck they may be melted and thus dissipate the electric energy by using it up as heat. Indeed, the best protection would probably be rendered by a system of wires fine enough that the current would melt them and thus save the building. One could however hardly put up a new system of wires after each stroke of lightning. There might not be time to install the new wires between the strokes, for lightning does strike twice in the same place. As we said before, we have published many articles upon lightning protection since these new facts caused a revision of practice in putting up lightning rods, and they may be found in our columns within fifteen years. Although this note is probably already the longest we have ever printed, we would add a reference to the work of the U. S. Weather Bureau upon this matter, which completely agrees with the foreign and American authorities we have so freely quoted. Any one interested may obtain these reports from the Superintendent of Documents, Government Printing Office, Washington, D. C. They are "Lightning and the Electricity of the Air," 50 cents, and "Recent Practice in the Erection of Lightning Rods," 10 cents. Inclose the money in coin or postal order, not in stamps. Valuable articles may be found in our SUPPLEMENTS 1212, 1452, 1581, 1524, and others to be found by reference to our Catalogue of Valuable Articles, which is sent free upon request.

NEW BOOKS, ETC.

TELEPHONE CONSTRUCTION METHODS AND COST. By Clarence Mayer, formerly Cost Statistician and Facilities Engineer, Chicago Telephone Company. Appendix A on Cost of Materials and Labor in Constructing Telephone Line, by J. C. Slippy, Consulting Telephone Engineer; and Appendix B on Miscellaneous Cost Data on Pole Line and Underground Conduit Construction, compiled by the Editors of Engineering Contracting. New York and Chicago: Myron C. Clark Publishing Company, 1908. 8vo.; pp. 284. Price, \$3.

This is a highly technical book, particularly adapted for the practical man, to whom a knowledge of construction costs is essential. It contains actual cost records which have been carefully compiled, as well as practical and flexible systems for the collection of such records and methods of computing, proportioning, and prorating costs of all kinds. Its pages contain the most approved methods of doing telephone work, and give the costs of such work in all its details.

AN INTRODUCTION TO ELECTRICITY. By Bruno Kolbe, Professor of Physics at St. Ann's School, St. Petersburg. A translation of a second edition of "Einführung in die Elektrizitätslehre," with corrections and additions by the author. Translated by Joseph Skellon, late Assistant Master at Beaumont College, Old Windsor. Philadelphia: J. B. Lippincott Company, 1908. 8vo.; pp. 430. Price, \$3.

Although we have many works on elementary electricity, the present volume will be welcome for the fact that it deals with the subject in a manner that is decidedly out of the ordinary. The material was originally delivered by Prof. Kolbe in the form of lectures to his class in St. Petersburg; and in order to present the subjects in a practical way, and one that would impress the students, he made a collection of electrical experiments which were new and directly to the point. Many of the experiments were original, and others were unearthed from the back numbers of scientific periodicals where they lay buried from the gaze of the general public. As a result the book entirely lacks the stereotyped illustrations which one invariably finds in works of this character. Part I covers

first the subject of static electricity, and dynamic electricity is taken up in the second part. The volume closes with an appendix containing historical remarks, repairs, and supplementary and practical hints.

THE PRINCIPLES OF MECHANICS. For Students of Physics and Engineering. By Henry Crew, Ph.D. New York: Longmans, Green & Co.; London, Bombay, and Calcutta, 1908. 12mo.; cloth; 295 pages; 110 figures. Price, \$1.50.

The author of this book is the Fayerweather Professor of Physics in the Northwestern University, and his work comprises lectures which during several years have been given to second-year students in physics in the institution. The previous training needed for pursuing the education laid down to the students is a course in general physics and one, either concurrent or antecedent, in the calculus. This course in the science of mechanics consists of kinematics, kinetics, some applications of general principles to special problems, friction, dynamics of elastic bodies, and fluid motion.

THE WONDER BOOK OF THE ATMOSPHERE. By Edwin J. Houston, Ph.D., Author of "The Wonder Book of Volcanoes and Earthquakes." New York: Frederick A. Stokes Company. 12mo.; cloth; 326 pages; 69 illustrations. Price, \$1.50.

The attempt has not been made in the book to explain all atmospheric wonders, the author assuming that they can be better treated in other Wonder Books in the series. The field of discussion has been wide enough to include, among other matters, the composition of the atmosphere, its temperature, climate, wind, moisture, dust, navigation, ozone, weather myths, and prodigies. The work is sufficiently painstaking and reliable, and a valuable contribution to scientific research of the phenomena of our thin shell of air. It is also a large addition to atmospheric folk-lore, to such an extent that much of the volume might be considered as material fitted for a wonder book of the imagination.

DEUTSCHER SCHIFFBAU 1908. Herausgegeben aus Anlass der ersten deutschen Schiffbau-Ausstellung in Berlin. Chefredakteur: Geh. Reg. Rat Professor Oswald Flamm, Charlottenburg. Lex. = 8°, 230 Seiten mit 239 Abbildungen. Verlag Carl Marfels, A.-G., Abteilung: Zeitschrift "Schiffbau," Berlin S. W. 68, Zimmerstrasse 9. Price, \$1.

This volume may be regarded as an expression of German engineers on German shipbuilding. The principal articles are "The Development of the German Navy," by J. Rudloff; "The Marine Engine, its Modern Design, and its Future Prospects," by Prof. Krainer; "The Marine Steam Turbine," by H. Schmidt; "Development and Present Status of Marine Boilers and Marine Auxiliary Machinery in Germany," by Prof. Walter Mentz; "Marine Gas Engines," by Prof. F. Romberg; "High School Training in Naval Architecture," by C. Flamm; "German Iron and Steel Industry and German Shipbuilding," by Fritz Luermann; "Shipyards," by Prof. W. Laas; "Cranes at the German Shipbuilding Exposition of 1908," by C. Michenfelder; "The German Shipbuilding Industry," by F. Meyer; "General Review of the Institutions and Authorities Identified with the Mercantile Marine," by Matthaei; "Electrical Plants for Ships," by C. Arldt; "Fitting Out Ships," by Fr. Jappe.

AUTOGENOUS WELDING OF METALS. By L. L. Bernier, M.E. New York: The Boiler Maker, 1908. Paper; 45 pages; illustrated. Price, \$1.

The chapters in this small work are translated from Reports of the National School of Arts and Trades of France, and illustrated by numerous figures and engravings. They describe the application of autogenous welding to the manufacture of tanks; gasometers; receptacles for liquids or gases, with or without pressure; steam and hot water boilers; kettles; small boats; automobiles; piping, either steel, copper or brass, and coils of all kinds; and also its application to repairing old or new castings injured through such defects as blowholes, cracks, etc. To these are added its application to the manufacture of steel, brass, bars and plates, and to the destruction of metals, structures, etc.

INDEX OF INVENTIONS

For which Letters Patent of the United States were Issued for the Week Ending October 6, 1908,

AND EACH BEARING THAT DATE

[See note at end of list about copies of these patents.]

Table listing inventions with patent numbers: Abrasive apparatus, O. C. Wysong... 900,249; Acid, making nitric, O. Bender... 900,471; Acid, making sulfuric, O. Bender... 900,688; Adjustable bracket, D. G. Bradstock... 900,475; Adjustable chair, C. H. Rhodes... 900,593; Air brake system, B. Akman... 900,639; Alarm, T. E. H. Buchanan... 900,145; Antiseptic attachment for telephones, F. C. Tabler... 900,447; Antiseptic mouthpiece for telephones, speaking tubes, etc., M. S. Hufschmid... 900,372; Arsenious oxid. manufacture of, U. Wedge... 900,138; Axle lubricator, J. Aden... 900,252; Axle spindle, T. L. Martin... 900,562; Axles, driving mechanism for swinging, A. H. Fetzer... 900,503

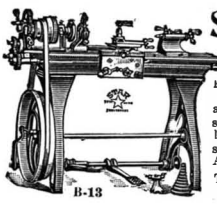

Severest Tests in accuracy, convenience and durability have been everywhere applied to our "Star" Foot and Power Lathes...

Engine and Foot Lathes MACHINE SHOP OUTFITS, TOOLS AND SUPPLIES. BEST MATERIALS. BEST WORKMANSHIP. CATALOGUE FREE

Foot and Power Lathes and Turret Lathes, Planers, Shapers, and Drill Presses. SHEPARD LATHE CO., 133 W. 24 St. Cincinnati, O.

Veeder Counters

to register reciprocating movements or revolutions. Cut full size. Booklet Free.

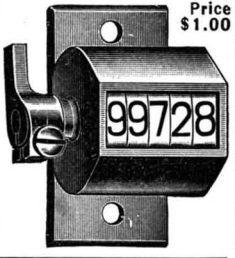

VEEDER MFG. CO. 18 Sargeant St., Hartford, Conn. Cyclometers, Odometers, Tachometers, Counters and Fine Castings.

SPECIAL TO AUTOBILISTS:

Bosh Magneto Plugs only \$1.25 each. Guaranteed in every respect. We sell automobile supplies cheaper than any supply house in the United States.

CONSUMERS AUTO SUPPLY CO. 1252-1254 Wabash Avenue, Chicago, Ills.

The Perfection Wrench

Newest wrench on the market. Best "all-round" tool ever made. All steel—great strength. Instantly adjusted. Easily and quickly operated.

THE PERFECTION WRENCH CO. Box 426, Port Chester, N. Y.

The "Electro" Static (Wimshurst) Machine

Guaranteed to generate in any kind of weather, no matter foggy or rainy. First machine ever constructed which can truthfully claim this. We absolutely guarantee a fat, powerful 3-inch spark.

MEASURING BAR CLAMPS

One inch square inside, used with two wooden bars 1 in. x 1/2 in. of any desired length. Clamps and bars thus combined are most convenient to carpenters as adjustable measuring rods.

Pipe Cutting and Threading Machine

This machine is the regular hand machine supplied with a power base, pinion, countershaft, etc., and can be worked as an ordinary power machine or taken from its base for use as a hand machine.

HOW Manufacturers Can Increase Their Business

Read carefully, every week, the Classified Advertising Column in the SCIENTIFIC AMERICAN. Some week you will be likely to find an inquiry for something that you manufacture or deal in.

Table listing various mechanical items and their prices, including Bag frame lock, Bag holder, Barrel raiser, Basket, Bath and stand, Bathometer, Battery cover, Bearing ball, Bearing for self closing liquid shut-offs, Bearing roller, Bed, Bed folding, Beer dispensing apparatus, Bicycle package carrier, Billiard table, Blind guide, Block signaling device, Boat, Boiler cleaner, Boilers, Bottle opener, Bottle or other vessel, Bottle stopper, Bottle washing machine, Box, Box fastener, Box fastener, Brazelet joint, Brake shoe, Brick machine attachment, Bridge dam, Building construction, Bunching and counting machine, Strasburg, Bundle tie, Burglar alarm, Button, By-pass, Cabinet, Cabinet, Laundry, Cake mixer, Calendar, Calendar, Camera back, Camera shutters, Can body flanging machine, Can making machine, Can tester, Cannon pinion, Car bolster, Car door, Car dumping, Car freight, Car operating mechanism, Car safety guard, Car underframe construction, Cars, sash window for railway, Carbureter, Carburetor, Carpet sweeper, Cart, Cartridge belt, Cartridge pocket, Cartridge shell repairing machine, Casket handle, Caster, Caster, Furniture, Caster, Furniture, Catamenial appliance, Catch for swing closures, Centrifugal block machine, Centrifugal machine, Chair, Chair, O. L. Ostendorf, Chair bottom clip, Chair canopy, Chairs, reclining attachment for, Chain, Chain, Checkrein hook, Chemical product resembling celluloid, Chenille spotting machine, Chromium, producing an electrolytic deposit of metallic, Chum dasher, Cigar box, Cigarettes, production of shells employed in the manufacture of, Circuit interrupter, Clock, alarm, Metz, Clocks and the like, portable case for, Clocks and the like, striking mechanism for, Clocks, program attachment for, Hansen, Clothes guard, Clothes line holder, Clutch, Clutch, Friction, Cock, blow-off, Cock or valve, water, Porter & Binnington, Coffee steeper, Coke drawing apparatus, Collapsible frame or support, Colors, process of fixing, Colors, producing indulin, Column step, Combination lock, Composition, Compressor, variable capacity, Concentrating table, Concrete building blocks, machine for constructing hollow, Condenser and making same, Controller, Controlling mechanism, Conveyor, Cooking utensil, traveling, Copper matte, bessmerizing, Corn crib, Corn, machine for removing silk from ears of, Cotton chopper and cultivator, Coupling mechanism, Cradle or rocker attachment, Crate, Crayon holder, Cross arm support, Cross arm support, Cupboard, folding camp, Cure of rheumatism and other diseases, appliance for the, Curling iron heater, electric, Current motor, alternating, Current rectifier, electrolytic alternating, Curtain pole, Cut-out mechanism, progressive, Cutting apparatus, Cutting, punching, and tire-shrinking machine, W. T. Sears, Cylinder lock, Waugh & Harendt, Damper regulator, Dancing chart and method of self instruction, Dental appliance, Diaper, baby's,

Important Books

Industrial Alcohol

ITS MANUFACTURE AND USES A Practical Treatise based on Dr. MAX MAERCKER'S "Introduction to Distillation" as revised by Drs. DELBRÜCK and LANGE. Comprising Raw Materials, Malt-ing, Mashing and Yeast Preparation, Fermentation, Distillation, Rectification and Purification of Alcohol, Alcoholometry, the Value and Significance of a Tax-Free Alcohol, Methods of Denaturing, Its Utilization for Light, Heat and Power Production, a Statistical Review and the United States Law.

By JOHN K. BRACHVOGEL, M.E. 528 Pages 105 Illustrations Price \$4.00

Experimental Science

By GEORGE M. HOPKINS Revised and Greatly Enlarged. 2 Octavo Volumes. 1,100 Pages. 900 Illustrations Cloth Bound. Postpaid, \$5.00

Owing to the amount of new matter added the book is now published in two volumes, handsomely bound in buckram. Of the additions which have been made, among the most important are: A full illustrated description of the H. P. Electric Motor, prepared expressly for this edition of "Experimental Science"; chapters on Alternating-current Machinery, and clear, concise Explanations of Wireless Telegraphy and Telephony Electrical Measuring Instruments, the Electric Clock, the Telegraphone. High Tension Currents, the Nernst Lamp, and methods of measuring the heat of the stars.

The Scientific American Cyclopedia of Receipts, Notes and Queries

15,000 RECEIPTS 734 PAGES Price \$5.00 in cloth

This splendid work contains a careful compilation of the most useful Receipts and Replies given in the Notes and Queries of correspondents as published in the SCIENTIFIC AMERICAN during the past sixty years together with many valuable and important additions. Over Fifteen Thousand selected receipts are here collected, nearly every branch of the useful arts being represented. It is by far the most comprehensive volume of the kind ever placed before the public.

Modern Plumbing Illustrated

By R. M. STARBUCK Price \$4.00

A COMPREHENSIVE and up-to-date work illustrating and describing the Drainage and Ventilation of Dwellings, Apartments, and Public Buildings, etc. The very latest and most approved methods in all branches of sanitary installation are given. Adopted by the United States Government in its sanitary work in Cuba, Porto Rico, and the Philippines, and by the principal boards of health of the United States and Canada. 300 pages; 55 full-page illustrations.

Modern American Lathe Practice

By OSCAR E. FERRIGO, M.E. Price \$2.50

A COMPLETE book of 400 pages on The Modern American Lathe. Its development from the earliest times up to the present day; its modern form as constructed by up-to-date builders; its general and special classes of work; the quantity of its output, and its marvelous accuracy.

Modern Steam Engineering in Theory and Practice

By GARDNER D. HISCOX, M.E. Price \$3.00

THIS is a complete and practical work of 487 pages, dealing with the care and management of Boilers, Engines, Pumps, Superheated Steam, Refrigerating Machinery, Dynamos, Motors, Elevators, Air-Compressors, and all other branches with which the modern Engineer must be familiar. Nearly Two Hundred Questions with their Answers on Steam and Electrical Engineering likely to be asked by the Examining Board are included. These if studied by you will help you to procure a license. It is fully illustrated with detail engravings, not to be found elsewhere.

Punches, Dies and Tools for Manufacturing in Presses

By JOSEPH V. WOODWORTH Price \$4.00

A PRACTICAL work of 500 pages fully illustrated by nearly 700 engravings, being an encyclopedia of Die Making, Punch Making, Die Sinking, Sheet Metal Working, and Making of Special Tools, Sub-Presses, Devices and Mechanical Combinations for Punching, Cutting, Bending, Forming, Piercing, Drawing, Compressing and Assembling Sheet Metal Parts, and also Articles of other Materials in Machine Tools. Two Hundred and Ten Processes are clearly described and fully illustrated.

A special circular describing these books sent on request. Any of these books sent prepaid on receipt of price. MUNN & CO., Publishers, 361 Broadway, New York

Dispensing vessel, H. von Baeyer, Display rack, E. B. Weston, Display rack, M. Mayer, Display rack attachment, E. B. Weston, Door hanger, J. Doran, Door holder, H. G. Voight, Doughnuts and the like, apparatus for turning, W. H. Tomlinson, Draft attachment for vehicle thills, T. H. Leonard, Driving mechanism, variable speed, M. E. Vaughn, Ear trumpet, K. F. Hackert, Ear trumpet, B. S. Stephenson, Egg tester, J. W. Burkholder, Electric furnace, R. McKnight, Electric furnace, J. H. Reid, Electric furnace, E. Cornelius, Electric generator, G. Honold, Electric switch, remote control, J. S. Bristol, Electrode for electrolytic purposes, Ferchland & Nussbaum, Electromagnet for telegraphones, Pedersen & Poulsen, Electroplating apparatus, J. A. Yuncck, Electroplating metal sheets, apparatus for, H. L. Hollis, Electrosonator, R. Sakamoto, Elevated carrier, Neller & Louden, Elevating and lowering device, universal, E. G. Gebauer, Elevator, S. V. Trent, Elevator safety device, J. N. Anderson, Elevator safety device, R. Bohlen, Elevator safety mechanism, P. F. Foley, Engine, H. L. Ide, Engine, M. E. Keller, Engine starter, gas, R. W. Sudrey, Engines and motors, alarm or signal system for, W. S. Rush, Engines, belt holder for, E. & C. Hicks, Engraver's spoon holder, F. W. Crocker, Envelop, E. Kohler, Eraser, ink, J. C. Huss, Excavating machine, W. M. Brown, Explosion engine, Cottrell & Moore, Extinguishing device, F. Hursthouse, Extractor. See Spike extractor, Eyeglasses and spectacles, converting device for, F. K. Stickle, Fabrics, machine for unraveling textile, P. F. Vogel, Fan, E. Goosch, Fastener, metallic, G. W. McGill, Faucet, L. S. De Forest, Faucet, J. G. Kasjens, Feed trough, C. B. Haldeman, Fence fastener, wire, J. H. Knickerbocker, Fence making machine, wire, J. M. Denning, Fence stay fastening machine, wire, Z. Hurd, Fender clip, W. C. Groehn, Fertilizer distributor, Roby & Pattison, Fiber preparing machine, A. Zabriskie, Fiber stripping and cleaning machine, S. O. Dickinson, File cabinet, C. G. Ward, Filter press, C. W. Merrill, Filter, pressure, P. E. Maggini, Filter, pressure, C. W. Merrill, Filter, rain water, L. W. French, Fire alarm electric, H. W. Anderson, Fire doors, etc., ventilator for, A. H. Lowry, Fire extinguisher, destructible link or automatic, J. D. Farr, Fire extinguishing apparatus, J. G. & H. G. Robinson, Fire protective shield, D. S. Watson, Fishing device, Welch & Wheatley, Fishing reel, G. E. Matts, Fixing and washing tank, G. H. Scheer, Floor clamp, F. Williams, Flue dust and fines, recovering values from, R. Baggaley, Flue dust, composition for solidifying, Ramsey & Smith, Flue plugger, W. B. Wingate, Fluid joint, flexible, C. G. Hawley, Fluid joint, flexible, E. E. Silk, Fluid pressure regulator, L. B. Fulton, Fluid receptacle, portable, L. Kessler, Folding box, J. M. Johnson, Folio box or crate, J. H. & E. El. Derby, Folding table, O. C. Kade, Fuel, manufacture of artificial, A. W. H. Vial, Furnace, W. Garvens, Furnace feeding mechanism, F. Kingsley, Furniture slat, F. P. Grode, Fuse cap, waterproof, T. M. Daniels, Garment fastener, E. B. Stimpson, Garment hanger, N. E. Miles, Garment supporter, C. W. Wallis, Gas engine, C. A. Clark, Gas generator, C. I. Tenney, Gas heater, J. S. Panasevitch, Gas making systems, boiler for, C. I. Tenney, Gas manufacturing apparatus, E. Rider, Gas manufacturing apparatus, H. Pettibone, Gas manufacturing apparatus, hydrogen, E. Geisenberger, Gases containing sulphur dioxide, purifying, G. Eschellmann, Gear, transmission, R. J. Millon, Gearing, W. J. Wilde, Glassware, method and apparatus for making, W. E. Holmes, Gluing frame, A. Hettel, Grader, road, E. A. Hollenbeck, Grain shucking machine, W. Leitch, Grinder for wood plane knives, Kahle & Himmelreich, Gum, production of a soluble, F. Fritsche, Gyrator, J. M. Schutz, Hair drying device, G. Siegfried, Harrow, J. D. McMillan, Harrow, C. E. Trease, Harvester, agricultural engine, and truck, self propelling combined, Kincaid & Preble, Hat frame, wire, C. W. Stevens, Hat sweat shield, H. W. Wagenet, Hay press, G. Rapp, Hay press, multiple, J. H. Means, Hay rake and elevator, combined, C. H. Knapp, Headlight controller, H. R. Parker, Heat from one medium to another, apparatus for transmitting, E. Marterud, Heating device, electric, W. C. Mortensen, Heating systems, vacuum generating apparatus for steam, W. E. Tillinghast, Heel nailing machine, E. A. Webster, Hide working machine, E. P. Whitney, Hinge, M. S. Nolan, Hinge for water closet seats, covers, and the like, post, G. A. Geary, Hinge, screen door spring, A. Falkenrath, Hinge, shutter, J. B. Williams, Hoisting machine, J. J. Say, Honey, extracting, L. W. Avant, Hood and reflector, G. Cutter, Hook and eye, J. P. Baumgartner, Hopper bottom catch, J. W. Egan, Horse detacher, J. R. Claxton, Horseshoe, P. Dech, Hose coupling, automatic air, N. Toy, Humidifier, F. B. Comins, Hydrocarbon burner, V. W. & L. S. Blanchard, Ice cream cornets, device for filling, M. Bohlig, Ice cream freezer attachment, O. R. Briggs, Ice cream spoon, C. E. McCarren, Insulated wires, moisture proof case for, A. L. Joynes, Iron, protecting, J. J. Bradley, Ironing table, A. E. Wise, Ironing table, M. J. Walker, Jack, Place & Jenkins, Jar opener, J. F. McCain, Jars and other receptacles, closure for, G. Valentine, Journal box, W. A. Huff, Key. See Telegraph key.



once and for all—no laundry bills or worn-out collars. With LITHOLIN you always have a perfect collar at hand—the one you are wearing—if soiled, just take it off and wipe white as new with a damp cloth.

Litholin

Waterproofed Linen Collars and Cuffs

Irreproachable in fit and style and look like regular linen, which they are, only water-proofed. Will save you \$16 a year. No wilting, cracking or fraying.

If not at your dealer's send, giving styles, size, number wanted, with remittance, and we will mail, postpaid. Booklet of styles free on request.

Collars 25c. Cuffs 50c.

The Fiberloid Co. Dept. 22 7 Waverly Place New York

Always sold from RED Boxes. Avoid substitution.

Make \$2,500 to \$7,500 Yearly

without capital. We teach you the real estate and general brokerage business by mail in a few weeks and appoint you

OUR SPECIAL REPRESENTATIVE in your locality. We help you from the start; put you in touch with all our representatives with whom you may co-operate in business; furnish you readily salable real estate and investments and help you secure customers. In short we put you in the way of an income instead of a salary; make you an employer instead of an employee. Write for our free booklet giving full information. INTER-STATE SALES CO., 237 Times Building, New York

Write for our free booklet giving full information.

Ann Arbor Lighting System advertisement with image of a lamp.

FOX MOTORS advertisement with image of a motor.

20 Years a Favorite! advertisement for furniture.

Palmer Motors advertisement with image of a motor.

Duryea's Buggy advertisement with image of a buggy.

Army Auction Bargains advertisement with image of a soldier.

Visible Writers advertisement with image of a typewriter.

How to Construct An Independent Interrupter advertisement.

Table listing various mechanical and electrical items with prices, such as Labeling machine, can, S. E. & W. W. Morral, Ladder, L. W. Thompson, etc.

"New Process" GILLETTE Blades advertisement with text: AN INSTANTANEOUS SUCCESS. Greater durability means a lessening to the already low cost of a daily shave with the Gillette Safety Razor.

GILLETTE SALES COMPANY advertisement with locations: New York, Boston, Chicago.

Winter Cruises to Summer Lands advertisement with image of a man in a hat and text: ORIENT, MEDITERRANEAN, ADRIATIC, EGYPT AND THE NILE, HOLY LAND, WEST INDIES, PANAMA CANAL, Etc.

The Latest and Best A. W. FABER DRAWING PENCILS advertisement with image of a pencil.

WORK SHOPS advertisement with image of a man working at a machine.

LEARN TO DRAW advertisement with image of a man drawing.

USE GRINDSTONES? advertisement with image of a grindstone.

Quality At Home in Spare Time advertisement with image of a man.

The Edison Concrete House advertisement with text: How it is constructed, how much it will cost, is it practical from an architectural and engineering standpoint?

"Responding to the Call"

from the practical mechanic for a Breast-Drill that shall eclipse all existing Tools of the kind, we are pleased to introduce the "A. J. W. & CO." BREAST DRILL with Gear Locking Device.

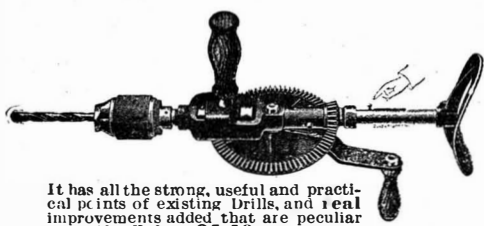

It has all the strong, useful and practical points of existing Drills, and real improvements added that are peculiar to itself. Price, \$3.50.

A. J. WILKINSON & CO. MACHINERY 184-188 Washington Street, BOSTON, MASS.

SEALED PROPOSALS.

PROPOSALS FOR MECHANICAL EQUIPMENT, Marine Corps, Quartermaster's Office, Washington, D. C., October 2, 1908. Sealed proposals, in duplicate, will be received at this office until 11 A. M., October 22, 1908, and then publicly opened for installing the Mechanical Equipment in Extension "B" Depot of Supplies, 1100 South Broad Street, Philadelphia, Pa.

SEALED PROPOSALS will be received at the office of the Light-House Engineer, Tompkinsville, N. Y., until 1 o'clock P. M., November 10, 1908, and then opened for furnishing and installing machinery in the new lamp-shed at the Light-House Depot, Tompkinsville, N. Y., in accordance with specifications, copies of which, with blank proposals and other information, may be had upon application to the Light-House Engineer, Tompkinsville, N. Y.

LET US BE YOUR FACTORY STAMPINGS, MODELS, EXPERT WORK THE GLOBE MACHINE AND STAMPING CO. 970 Hamilton St., Cleveland, O.

ICE MACHINES Corliss Engines, Brewers' and Bottlers' Machinery. THE VILTRER MFG. CO., 899 Clinton St., Milwaukee, Wis.

MODELS & EXPERIMENTAL WORK. Inventions developed. Special Machinery. E. V. BAILLARD, 24 Frankfort Street, New York.

RUBBER Expert Manufacturers Fine Jobbing Work PARKER, STEARNS & CO., 228-229 South Street, New York

ELECTRIC GOODS.—Big Cat. 3 cts. Want Agents. Ohio Electric Works, Cleveland, O.

HOEFT & COMPANY Die Makers, Machinists and Machinery Builders 120 Michigan St., Chicago, U. S. A.

MOORE Special Machinery, Dies, Tools, Models, Metal Specialties, Inventions perfected. Ludians and Franklin Streets, Chicago, U. S. A.

Experimental & Model Work Ovr. & advice free. Wm. Gardam & Son, 221 Fulton St., N.Y.

MODELS & CHICAGO MODEL WORKS ESTABLISHED 1867 179 E. MADISON ST. CHICAGO, ILL. WRITE FOR CATALOGUE OF MODEL SUPPLIES

INVENTORS We manufacture METAL SPECIALTIES of all kinds, to order; largest equipment; lowest prices. Send perfect sample for FREE estimate and best expert advice THE EAGLE TOOL CO., Dept. A, Cincinnati, O.

DRYING MACHINES For all kinds of granular materials. S. E. Worrell, Hannibal, Mo.

NOVELTIES & PATENTED ARTICLES MANUFACTURED BY CONTRACT PUNCHING DIES, SPECIAL MACHINERY. E. KONIGSLOW STAMPING & TOOL WORKS, CLEVELAND, O.

MASON'S NEW PAT. WHIP HOIST for Outrigger hoists. Faster than Elevators, and hoist direct from teams. Saves handling at less expense. Manfd. by VOLNEY W. MASON & CO., Inc. Providence, R. I., U. S. A.

THE SCHWERDTLE STAMP CO. STEEL STAMPS, LETTERS & FIGURES BRIDGEPORT CONN.

Magical Apparatus. Grand Book Catalogue. Over 700 engravings 25c. Parlor Tricks Catalogue, free. MARTINKA & CO., Mrs., 493 Sixth Ave., New York

TELESCOPES SEND FOR CATALOGUE W. & D. MOGEY, BAYONNE CITY, N. J.

WANTED A Practical, Patented Hose Supporting Device SUSPENDERS, Box 773, New York

LEARN WATCHMAKING We teach it thoroughly in as many months as it formerly took years. Does away with tedious apprenticeship. Money earned while studying. Positions secured. Easy terms. Send for catalog. ST. LOUIS WATCHMAKING SCHOOL, St. Louis, Mo.

FREE Squab Book, How to make money breeding Squabs PLYMOUTH ROCK SQUAB CO, 361 Howard St., Melrose, Mass

CEMENT BOOKS. How to Use Portland Cement 50c.; Cement Sidewalk Construction, 50c.; Reinforced Concrete Construction, \$2.50; Hollow Concrete Block Building Construction, 50c. Sent postpaid. CEMENT AND ENGINEERING NEWS, Chicago, Ill.

HOW TO MAKE AN ELECTRICAL Furnace for Amateur's Use.—The utilization of 110 volt electric circuits for small furnace work. By N. Monroe Hopkins. This valuable article is accompanied by detailed working drawings on a large scale, and the furnace can be made by any amateur who is versed in the use of tools. This article is contained in SCIENTIFIC AMERICAN SUPPLEMENT, No. 1182. Price 10 cents. For sale by MUNN & CO., 361 Broadway, New York City or by any bookseller or newsdealer.

Table listing various mechanical parts and their prices, such as Well packers, anchor mechanism for, G. A. Spang, 900,440.

DESIGNS.

Table listing various designs and their prices, such as Badge, T. F. Gaynor, 39,599.

TRADE MARKS.

Table listing various trade marks and their prices, such as Atomizing apparatus for medicinal use, R. L. Benson, 70,785.

LABELS.

Table listing various labels and their prices, such as "Malt Vita," for malt extract, Garden City Brewery, 14,386.

PRINTS.

Table listing various prints and their prices, such as "School, a New Parlor Game," for a game, J. F. McIndoe, 2,355.

A printed copy of the specification and drawing of any patent in the foregoing list, or any patent in print issued since 1863, will be furnished from this office for 10 cents, provided the name and number of the patent desired and the date be given. Address MUNN & CO., 361 Broadway, New York.

Canadian patents may now be obtained by the inventors for any of the inventions named in the foregoing list. For terms and further particulars address MUNN & CO., 361 Broadway, New York.

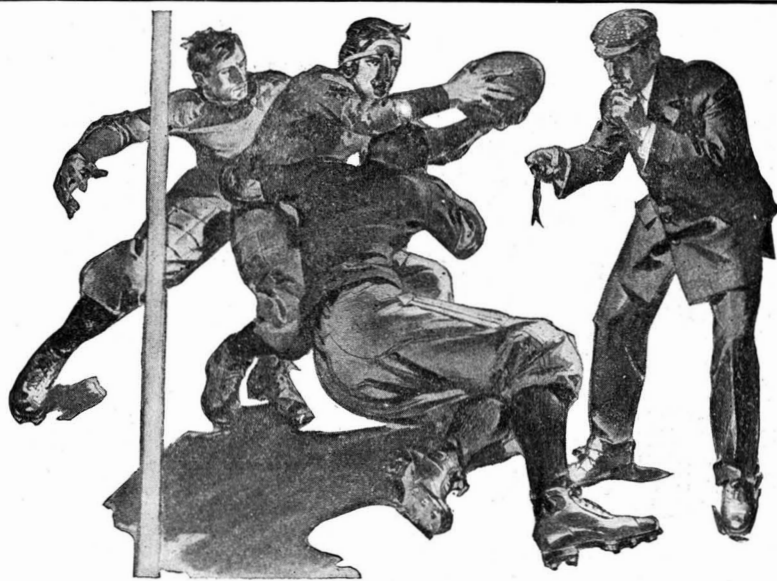

The Howard Watch

Wherever Time is called, the HOWARD watch has respect and authority. On the gridiron—or in the grand-stand with the spectators—wherever interest hangs on the tick of a second—the HOWARD is a watch of record and an arbiter of disputes. Edward Howard made the first American watch—changed the methods and revolutionized the watch industry of the world. Foreign watches are made today with American tools, invented by Howard in 1842.

Find the HOWARD Jeweler in your town and talk to him—he's a man worth knowing. Drop us a postal card, Dept. P, and we will send you a HOWARD book, of value to the watch buyer.

E. HOWARD WATCH COMPANY, Boston, Mass.

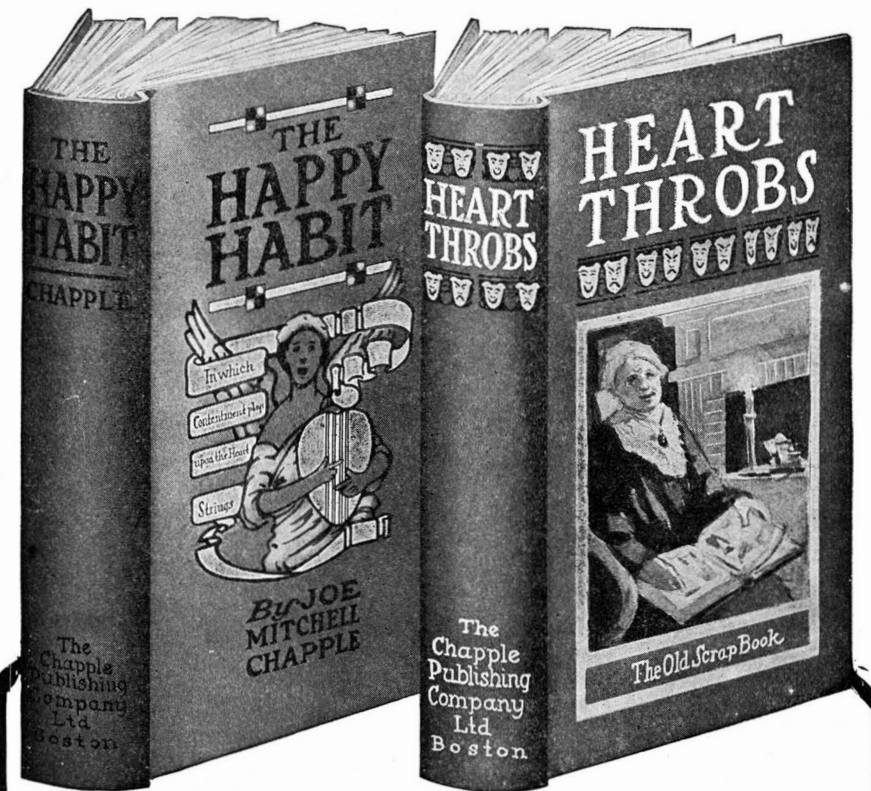

Two Great Library and Gift Books Treasured In Thousands of American Homes

THE HAPPY HABIT

There is no other book like "Happy Habit." A rare book of good fellowship, full of friendly chatty reminiscence that "talks things over" and tells of happy living—not all rollicking, but dignified and cheery. It's so human that it readily adapts itself to the personality of the reader, giving delight and pleasure by its charming conversational tone—like one friend visiting with another. In this it is a worthy companion to "Heart Throbs" and makes a most acceptable gift to man or woman. Nearly 500 pages, handsomely bound, gold illuminated cover. Price \$1.50.

At All Book Stores or Direct from Chapple Publishing Co., Boston

HEART THROBS

Fifty thousand people in all walks of life made this book their own—their very own—by contributing gems of sentiment in wit, humor, pathos, together with the masterpieces of all the authors of note, that have appealed to them in their own lives. Nearly one thousand "favorites" gleaned from all literature down to the present day, to lie on the library table for little "peeps" of inspiration and comfort. In uniqueness and worth "Heart Throbs" fills a special "want" among the givers of books. Nearly 500 pages, handsomely bound, gold, illuminated cover. Price \$1.50.

PUBLISHER'S SPECIAL OFFER

Both books combined with one year's subscription to THE NATIONAL MAGAZINE, the favorite magazine in a quarter-million homes, edited by Joe Mitchell Chapple, author of "Happy Habit."

\$4.50 value for \$3.00

COUPON

CHAPPLE PUBLISHING CO., BOSTON, MASS. GENTLEMEN: Enclosed find \$..... for which please send me "Heart Throbs," "The Happy Habit" and one year's subscription to The National Magazine. Name..... Address.....

DON'T BUY GASOLINE ENGINES UNTIL YOU INVESTIGATE "THE MASTER WORKMAN"

alcohol engine, superior to any one-cylinder engine, revolutionizing power. Its weight and bulk are half that of single cylinder engines, with greater durability. Costs Less to Buy—Less to Run. Quickly, easily started. Vibration practically overcome. Cheaply mounted on any wagon. It is a combination portable, stationary or traction engine. SEND FOR CATALOGUE. THE TEMPLE PUMP CO., Mrs. Meagher and 15th St., Chicago. THIS IS OUR FIFTY-FIFTH YEAR.



WE MANUFACTURE MOULDED AND SPECIAL RUBBER GOODS OF EVERY DESCRIPTION AND CAN FURNISH ANY SPECIAL RUBBER ARTICLE TO YOUR SATISFACTION

NEW YORK BELTING & PACKING CO. LTD.
91-93 CHAMBERS STREET,
NEW YORK

ROTHWEILER

The Wrench with a Grip



THE ROTHWEILER WRENCH is different. It is lighter, more powerful, has fewer parts and will last longer than any other pipe wrench on the market. Made of the best selected tool steel. Upper jaw, shank and handle forged in one piece. Has a firm, sure grip and a quick release. A wrench that you can depend upon absolutely under any and all conditions. Ask your dealer for the Rothweiler wrench and insist upon getting it. Household size by prepaid express \$2.00.

Illustrated Booklet mailed Free upon request

Crescent Forgings Company
1203 Railroad St., Oakmont, Pa.

CRUDE ASBESTOS

DIRECT FROM MINES

PREPARED ASBESTOS FIBRE for Manufacturers use

R. H. MARTIN,
OFFICE, ST. PAUL BUILDING
220 B'way, New York.

LEARN TO BE A WATCHMAKER

Bradley Polytechnic Institute
Horological Department
Peoria, Illinois
Formerly Parsons Horological Inst.
Largest and Best Watch School in America

We teach Watch Work, Jewelry, Engraving, Clock Work, Optics, Traction reasonable. Board and rooms near school at moderate rates. Send for Catalog of Information.

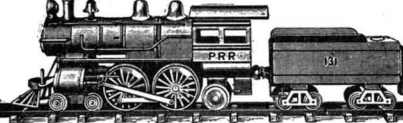

By Rail to Boyville

EVERY boy in the country can easily OWN an Electric railroad. For Christmas time our models of Electric Locomotives, Trains, Trolley Cars, Dynamos, Lamps, Electrical Novelties, etc., make splendid presents. Equipped with dry batteries. No acids or liquids. Safe and harmless. Catalog fully illustrated—quoting low prices—sent FREE.

THE CARLISLE & FINCH CO.
233 E. Clifton Ave., Cincinnati, Ohio

Robert Pocket Meters

For general battery testing
Dead-Beat Accurate, Durable, Guaranteed
Send for Catalogue

Volt-Ammeters
0-3 Volts, 0-30 amperes, \$6, incl. leather case
0-6 Volts, 0-30 amperes, \$7, " " " "
0-12 Volts, 0-30 amperes, \$8, " " " "

Ammeters
0-30 amperes, \$1, incl. leather case

Volt-Meters
0-3 Volts, \$3, incl. leather case
0-6 Volts, \$4, " " " "
0-12 Volts, \$5, " " " "

ROBERT INSTRUMENT CO.
62 Shelby St., Detroit, Mich.



HELMET OIL

LUBRICATES SEND FOR SAMPLE ANYTHING FREE

13-21 S. CLINTON ST.
CH. BESLY & CO. PHILADELPHIA, U.S.A.

The Rapid

Pays Big Dividends

RAPIDS—which are exclusively commercial motor cars for all purposes—pay big dividends on their first cost from the fact that they cost much less to operate and maintain than the necessary number of men, horses and wagons to do an equal amount of work. And they do the work so much more quickly and satisfactorily. Rapids are unquestionably the demonstrated success of modern, 20th Century methods of trucking—merchandise delivery—passenger car transportation and sight-seeing, as well as for police and hospital service. So, whether you are a manufacturer or merchant, interested in commercial motor cars, or wish to engage in a most profitable business with one or more sight-seeing Rapid Passenger Cars or are prepared to properly represent us as our agent, I ask you to write us and let me submit all facts which apply to your requirements. We are

Makers of Commercial Cars Exclusively

No other manufacturers in America even claim to be prepared to furnish commercial cars exclusively for every purpose. Our many years of experience—Our list of patrons—Our Rapid Cars themselves, as shown in every style and variation of style to suit every requirement, all constitute our claim for your consideration. We do not allow agents to represent us unless they are prepared to properly demonstrate Rapids to prospective purchasers who are constantly writing us. So I ask you to write to the factory—let us know your requirements and I will see to it that you are promptly furnished all facts—figures—prices—and comparative advice based upon our valuable records covering our own many years experience and the experience of representative users of Rapid Cars. Your inquiry, stating your requirements, will have my prompt attention.

H. G. Hamilton, Treas.
Rapid Motor Vehicle Co.
507 Rapid Street
Pontiac, Mich.



Showing One Style Rapid 1½-Ton Truck



WEBER Engine and Producer

40 to 700 H. P. units; uses Bituminous, Anthracite, Charcoal, Lignite or Coke.

IDEAL POWER CHEAPER THAN STEAM.

Successful plants in all parts of North America. Horizontal Gasoline Engines; sizes, 3 to 30 H. P. Best for over 25 years. Buy from the builder.

Weber Gas Engine Co.,
KANSAS CITY, MO.
Box 423

A Wonderful Automatic Pump

For supplying running water in summer hotels and resorts, sanatoriums, irrigation purposes, dairies and country houses, the

Niagara Hydraulic Ram

has no equal. Requires no attention; no cost for repairs. Write for Booklet AA and guaranteed estimate. We furnish Caldwell Tanks and Towers.

NIAGARA HYDRAULIC ENGINE CO.
140 Nassau St., N. Y. Factory: Chester, Pa.



METAL POLISHES.—FORMULAS FOR Putz Pomades, Pastes, Liquids, Powders and Soaps for polishing metals, are contained in **SCIENTIFIC AMERICAN SUPPLEMENT** Nos. 1283, 1288 and 1289. Price 10 cents each from this office and all newsdealers

FREE STOVE and RANGE BOOK

64 pages Free

Write for it today! This book will save you from \$12 to \$30 when you purchase a stove or range. It explains how the best and finest stoves and ranges in the world are made, and tells you how to "know the best."

HOOSIER STOVES and RANGES FROM FACTORY TO USER

Are heavily made of highest grade selected material, beautifully finished, with all new improvements and features. "Guaranteed for Years," backed by a million dollars. "Hoosiers" are fuel savers and easy bakers. A child can operate them. Sold on 30 days free trial. No freight to pay.

Write for Free Stove Book AND OUR SPECIAL FREE TRIAL OFFER

HOOSIER STOVE FACTORY, 257 State St., Marion, Indiana





SEA LION AND RELIANCE

Guaranteed Leather Belting

Center stock—cut from choicest selected hides, oak bark tanned in the old-fashioned way. Not well and done right. Long practice has given our workmen such deft hands, quick eyes and all round skill that each is master of his special task. That is why leather belting that bears the **Reliance or Sea Lion Waterproof Brand** means greatest economy—longest wear—highest efficiency—thorough reliability. We also make Imperial, Sterling and Dynamo brands that are equally as good values for specific purposes. Under what conditions do you have to run your belts? Write and describe them and we will advise you what is best to buy and send an interesting book on leather belting.

CHICAGO BELTING CO., 24 S. Green St., CHICAGO, ILL.
Branches—New Orleans, Philadelphia, Portland, Ore.

Engineering News

(ILLUSTRATED)

The Leading Engineering Paper of the World. For Civil, Mechanical, Mining and Electrical Engineers.

100 to 125 pages, 9" x 13", weekly. Send ten cents for sample copy.

THE ENGINEERING NEWS PUBLISHING CO., 214 Broadway, New York

If you haven't read our page "ads" in current magazines, send for catalog of the self-starting, six-cylinder

WINTON SIX

48 H.P. \$3000
60 H.P. \$4500
Goes the route like coasting down hill



The Winton Motor Carriage Co.
1080 BEREA ROAD, CLEVELAND, OHIO

COLD GALVANIZING.

AMERICAN PROCESS. NO ROYALTIES. SAMPLES AND INFORMATION ON APPLICATION.

Established 1820.



NICKEL AND Electro-Plating Apparatus and Material

Hanson & VanWinkle Co.,
Newark, N. J.
28 & 30 S. Canal St. Chicago.

CENTER-FIRE SPARK PLUGS

The Racing Machine Plug. Guaranteed to add 10 Per Cent Power to engine. Fire charge in center of compression, causing perfect combustion. Soot proof. Samples \$1.00, or six for \$5.00. Regular price \$1.75 Guaranteed. Give name of car and year. Agents wanted. Write

GENERAL ACCUMULATOR & BATTERY CO.
128 Second St., Milwaukee, Wis.

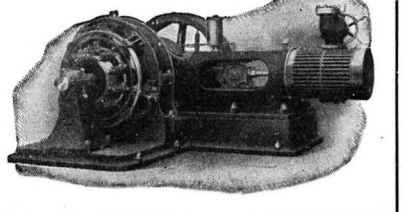
FIXED BRUSHES

DYNAMO ABSOLUTELY SPARKLESS AT ALL LOADS

10 K.W. TO 500 K.W. DIRECT CURRENT
15 TO 1500 H. P.

Ask for Bulletin 19

RIDGWAY DYNAMO & ENGINE COMPANY
Ridgway, Pa.

The Great Divide

Knowledge is the great divide between the man who works and the man who plans. The Civil Engineer is, above all others, the pioneer of progress. His field includes almost every phase of our industrial, commercial, municipal and national life, and almost every measure affecting public health, comfort or convenience.

CYCLOPEDIA OF Civil Engineering

8 VOLUMES—page size 7 x 10 inches—nearly 4,000 pages—3,000 illustrations, diagrams, plates, formulas, etc.—BOUND IN HALF RED MOROCCO.

This is the first great reference work ever compiled covering the entire field of Civil Engineering with all of its allied branches. The work represents the combined efforts of a large staff of practical experts. It is admirably adapted to the needs of the beginner and self-taught practical man in addition to meeting all demands of the technically trained expert. It is complete, clear and simple—compiled especially for Home Study.

SPECIAL ADVANCE OFFER

Reserve set now. Sent express prepaid for 5 days' FREE examination if you mention October 17, 1908, SCIENTIFIC AMERICAN. If you wish to keep the books pay \$2 within 5 days and \$2 a month until you have paid the special price of \$24.00. Regular list price is \$48.00. We send for the books at our expense if not wanted.

Brief List of Contents

Plane Surveying—Mechanical Drawing—Plotting and Topography—Railroad Engineering—Statics—Strength of Materials—Roof Trusses and Mill Building Construction—Cost Analysis in Relation to Engineering—Masonry and Reinforced Concrete—Steel Construction—Practical Problems in Construction—Bridge Engineering—Highway Construction—Hydraulics—Water Supply—Irrigation Engineering—Water Power Development—Sewers and Drains—House Drainage and Sanitation—River and Harbor Improvements.

AMERICAN SCHOOL OF CORRESPONDENCE
CHICAGO