

AN ENGINE WITH LOW-TENSION MAGNETO IGNITION.

The engine of the 35-horse-power Locomobile touring car, which is shown in the accompanying illustration, is a typical example of a 4-cylinder, vertical, water-cooled engine fitted with the simplest type ignition, namely, make-and-break, fed by current from a gear-driven magneto. The igniters are shown in the inlet chambers of the four cylinders as at *b*, while they are all operated by vertical rods, *c*, that are pushed upward by tapered cams in the crankcase, and that make a sudden descent in slipping off the cam and being pulled downward by a spring. This causes the hammer, *H*, of the igniter to be suddenly moved away from the anvil, *A*, thus breaking the contact between the points and making a large, flaming spark. The whole igniter mechanism fits in a plate, *P*, having a ground tapered seat, and which is attached to the inlet chamber by three nuts. Besides this, the insulated pole, or anvil, is made up of a separate mica plug, *C*, having a tapered steel sleeve, *B*, which fits in a tapered hole in the plate and makes a gas-tight joint. *B* is provided with a thread, *s*, that carries a large clamping nut. Washer, *w*, and nut, *n*, clamp together the mica washers that make up the core, *C*. The iridium points are set into the small arms of the anvil, *A*, and the hammer, *H*, through tapered holes in the ends of these parts. The points are then brazed into place, and the holes behind them are filled. Loss of the points is therefore impossible, and the wear upon them is so slight that each set will easily last for 10,000 miles. In the photo of the engine *a* is an insulated handle that operates a small knife switch and cuts out the igniter. These are fitted to all four igniters and are used for the purpose of testing. The four caps, *o*, seen over the inlet valves, are for the purpose of allowing these valves to be removed, if it is necessary to grind them at any time. The valve springs are attached to the valves by passing through holes in the latter. The same arrangements are duplicated on the exhaust side of the motor. The gear-driven magneto is seen at *M*, the carbureter at *C*, the auxiliary piston air valve (which has a special type of very sensitive coiled spring) at *A*, and the inlet pipes to the cylinders at *B*. At *d* is the pivot which connects the rod that runs forward from the piston throttle valve of the carbureter to the lever arm of the governor. By pressing on the accelerator pedal, *X*, the driver can throw the governor out of action. The fan belt is shown at *e*. *O* shows a number of oil pipes that come up from the oiler (placed below the footboard and driven by a wire belt) and connect with a row of sight feeds on the dash, whence they lead to the crankcase of the engine and other points that need oiling.

The magneto used on this car is made by the manufacturers of the latter. The magnets employed in its construction are of the very best quality obtainable, and will hold their magnetism for a very long time. All the working parts of the magneto are thoroughly protected.

The 20- and 35-horse-power models which the Locomobile Company is building this year, both have a final individual chain drive, and are fitted with Hess-Bright ball bearings in the wheels and transmission. All the features of a high-class car, such as pressed-steel frame, alloy steel in shafts, gears, and many other important parts, are found in the 1907 Locomobile touring car. The general appearance of this machine can be noted from the photograph reproduced on page 33

AN AUTOMOBILE MOTOR WITH ROTARY VALVE.

The Duryea Power Company exhibited for the first time, at the recent show in the Grand Central Palace, a decided innovation in the form of a rotary-valve triple-cylinder engine. Mr. Charles E. Duryea has been experimenting with this device as opportunity permitted for the last four years, and has been marketing it regularly to a limited extent during the past season. His exper-

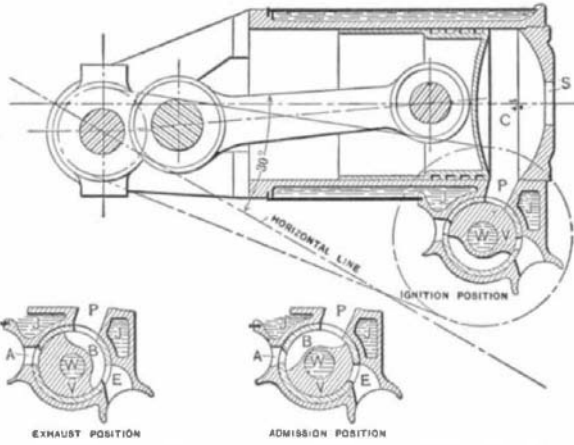

WATER-COOLED ROTARY VALVE APPLIED TO A 3-CYLINDER DURYEA ENGINE.

A. Inlet port from carbureter. *B.* Cut-away part of valve. *C.* Cylinder. *E.* Exhaust port. *J.* Water jacket around valve. *P.* Inlet port of cylinder. *V.* Rotary valve. *W.* Hole in valve for water. *S.* Spark-plug hole.

ience with it thus far has been so satisfactory that he intends to push its manufacture more vigorously hereafter. This valve, as can be seen from the drawing, consists of a single revolving shaft having three

(Continued on page 52.)

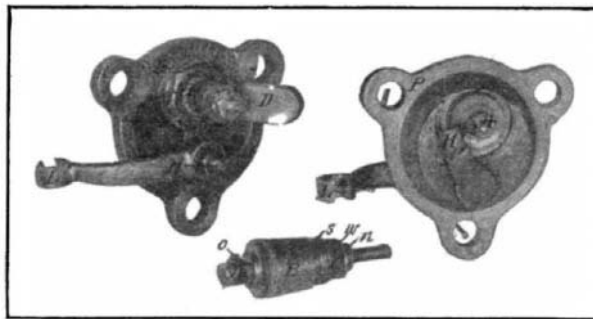

MAKE-AND-BREAK IGNITER OF THE LOCOMOBILE ENGINE.

A. Anvil. *B.* Tapered sleeve surrounding mica insulating core. *C. D.* Connector from insulated pole to knife switch. *H.* Hammer of movable electrode. *L.* Lever for operating hammer. *P.* Plate carrying complete igniter. *o.* Iridium point set into anvil. *s.* Thread on sleeve *B* for large nut. *w, n.* Clamping washer and nut for core, *C.*

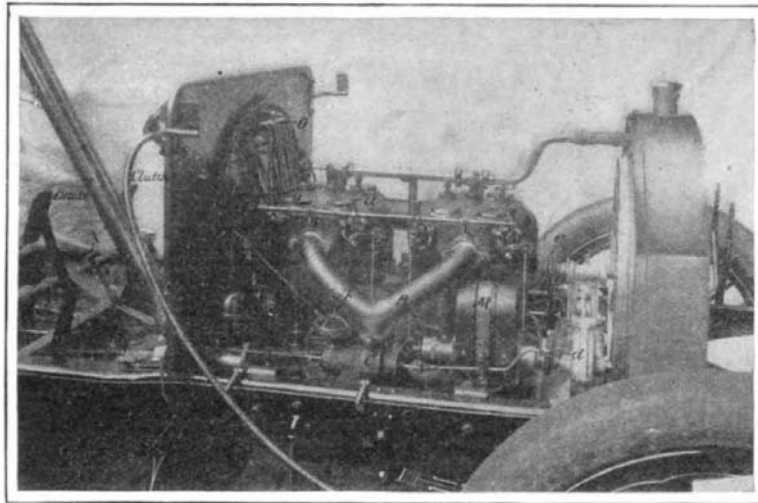

FRONT END OF CHASSIS OF LOCOMOBILE 35-HORSE-POWER TOURING CAR.

A. Auxiliary air valve of carbureter. *B.* Inlet pipe. *C.* Carbureter. *M.* Magneto. *O.* Oil pipes. *X.* Accelerator push pedal. *a.* Knife switch for igniter. *b.* Make-and-break igniter. *c.* Igniter operating rod. *d.* Governor lever arm connection to throttle. *e.* Fan belt. *o.* Valve cap.

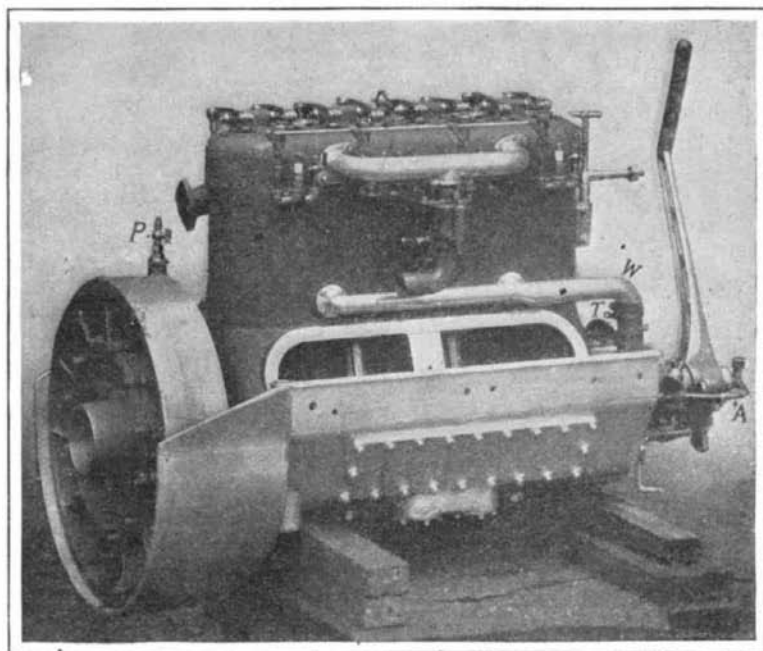

THE 50-HORSE-POWER 5 X 5 1/2-INCH ENGINE OF THE NORTHERN TOURING CAR.

Note the air-operated clutch inclosed in the flywheel and the lever starting device used in place of a crank.

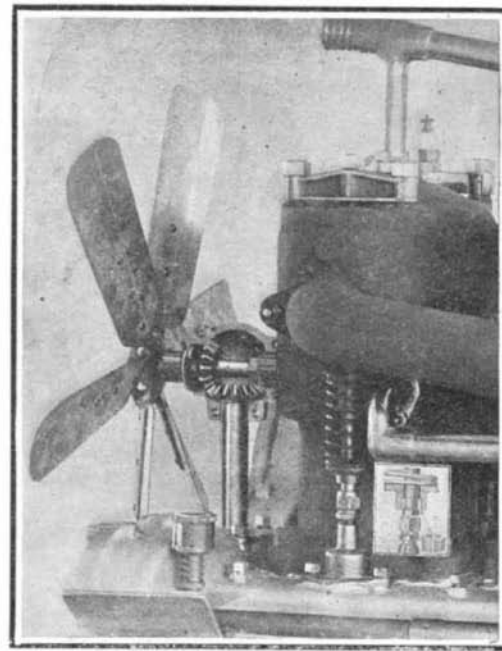

FRONT END OF THOMAS ENGINE, SHOWING BEVEL-GEAR-DRIVEN FAN.

The small sectional drawing shows method of securing valve-spring washer in place on stem by a split ring fitting into a groove on the valve stem. This simple device makes the valve spring instantly removable by prying up the washer.

ENGINE OF THE 60-HORSE-POWER THOMAS CAR.

Progressive manufacturers have sought to improve their cars for this year not only by using the best materials, but also by doing away with all features which experience has shown are liable to break down, give out, or otherwise cause trouble. Water circulating pumps have been gear-driven instead of chain-driven for some time past, and now the tendency is to do away with all belts whatsoever. This tendency is illustrated well in the accompanying photographs of the Thomas engine, which show a fan driven by bevel gears, a spiral spring (not shown) being interposed in the drive. On the opposite side of the engine is a gear-driven, high-tension magneto, while the shaft seen at the bottom of the picture driving the gear water pump is extended back through the dash (the extension having two universal joints) and used to drive a new spark generator (Atwater-Kent device) consisting of a spark coil with mechanically-operated contact arrangement and secondary distributor, which draws its current supply from four dry batteries. This contact produces a single spark only, while the contact is so very short that an almost infinitesimal current flows each time and, as a consequence, one set of dry batteries will run a 4-cylinder car from 2,500 to 3,000 miles. A special button on the containing case makes it possible to jump a spark in the cylinder that is on compression and thus, oftentimes, to start the motor from the seat. The magneto is used as the regular ignition supply, while the device just described serves as a reserve.

The lubricator, also, is driven by bevel gears. Its horizontal shaft projects through the dashboard, and a vertical shaft rises up from the engine base to drive it. There is no commutator or timer on the car, as both the magneto and generator mentioned are gear-driven and properly set.

THE 50-HORSE-POWER NORTHERN ENGINE.

The Northern 50-horse-power 5 x 5 1/2-inch, 4-cylinder engine is a solitary example of an engine having cylinders and upper half of crank case formed of one integral casting. Another novelty about this engine is that the water jackets are galvanized, thus preventing rusting. The valves are arranged in a row in the cylinder heads and are operated by tappets and push rods from a single camshaft. This camshaft is provided at its rear end with a crank for operating the piston of an air pump the top of which is provided with a valve, seen at *P*. A connection can be made here for blowing up the tires, though the prime purpose of the pump is to provide air at 50 pounds pressure for operating the clutch and band brakes on the rear wheels. This compressed air, reduced to 2 pounds pressure, also forces gasoline from the tank to the carbureter. The air for the clutch is led through a curved pipe, *A*, into the hollow crankshaft at its forward end, and passes through the latter to the clutch (seen in the flywheel) where it presses together a floating leather disk and another attached to the flywheel, clamping between them a steel disk on a stub shaft attached to the propeller shaft through a universal joint. The power is applied to the wheels through a 3-speed transmission located at the rear axle. The bottom half of the crankcase is an aluminum casting with flaring sides that abut against the sides of the frame and are bolted to them. This casting contains an oil reservoir with inlets to the crank case controlled by a float-operated valve which is depended upon to automatically maintain the proper oil level in the case. The lubrication is entirely by splash. The upper crank case has large hand holes through which the bearings can be readily adjusted. By extending the lower crank case to the frame. Mr. Charles B. King, the designer of the Northern car, has completely closed in the engine without using a sep-

(Continued on page 53.)

charge. A slight comparison of the duties of this valve with the crankshaft of the same engine is interesting. The area of the 5-inch piston is approximately 20 square inches, while the area of the exposed surface of the valve is but a little over one-tenth this amount, being less than 2¼ inches. The bearing surface of the valve shaft extends the full width of the cylinder, whereas the bearing surface of the crankshaft does not total one-half of this amount, because of the crank-arms and crankpins which must be provided for. From this it will be seen that the work done by the valve is but 1/20 the work done by the crankshaft, and yet to provide ample packing surface, the valve diameter and consequent surface is 30 per cent greater than the crankshaft diameter. From this comparison, as well as from the results given in practice, it is readily seen that the life of the valve should be very long under normal usage.

Experiments have been made with tapered valves fitting their bushings as does an ordinary stopcock, but trial of both kinds has convinced Mr. Duryea that even the slight added cost and complexity of the tapered form is not necessary to secure the desired results.

In service, the rotary valve engine runs almost like a steam engine. The mechanical operation of the inlet permits perfect admission of the attenuated charge admitted at low throttle, and secures a wide range of speed because of this smooth running at low speeds, as well as because of the lack of reciprocating parts, which clatter and pound badly at high speeds. The crankshaft bearings are made quite large, and the connecting rods are forged and of so strong a design that high speeds cannot damage them.

The prediction is freely made that this invention is one of the most marked improvements in the four-cycle gasoline automobile motor that have been made in recent years. Mr. Duryea has several patents pending upon this device.

THE 50-HORSE-POWER NORTHERN ENGINE.

(Continued from page 25.)

arate steel pan. Nipples screwed into the cylinders just above the highest point of piston travel carry horizontal pipes with three vertical outlets, the center one of which carries a spark plug, the right-hand one a priming cock, and the other a patent relief valve for each cylinder. The relief valves are all connected together so that the chauffeur can, by pulling a handle, put them all in operation when turning over the engine. These valves only open when the compression occurs, and as soon as an explosion takes place, they instantly close.

The motor is started by a long lever having a pawl that engages the teeth of a ratchet wheel on the crankshaft. The movement of the lever in starting the engine automatically retards the spark. The two-to-one gears are shown incased at T, and are used as a water pump to force the cooled water received from the bottom of the radiator through the large pipe, W, leading to the bottom of the water jackets. The bracket for the fan belt pulley, seen at the front end of the engine, is mounted on a vertical spindle that can be raised or lowered by turning the star wheel on top. Thus the fan belt can be easily and quickly tightened. The cylinders of the Northern engine are slightly offset, which gives a more direct thrust on the working stroke.

A SUCCESSFUL FRICTION-DRIVE AUTOMOBILE.

(Continued from page 26.)

tenber engine rated at 40 H. P. at 1,000 R. P. M. The timer is shown at T. P is one of the connections between the timer and the base of the steering column, V, for advancing the spark by means of one of the levers that travel over the stationary segment in the steering wheel. The motor is provided with an 8-feed mechanical oiler, which efficiently lubricates it.

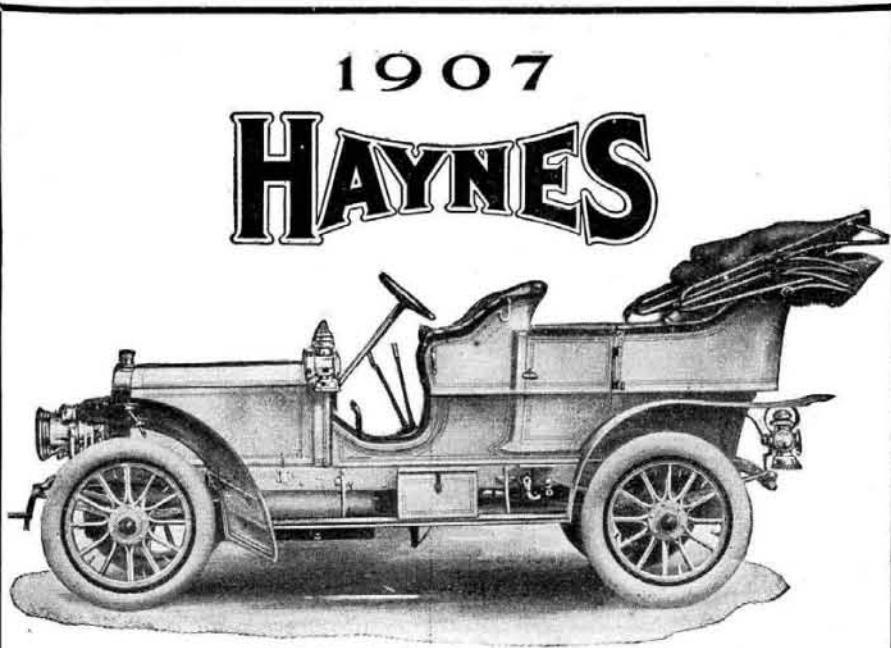

The Haynes Standard 50 H.-P. Touring Car for 1907, Model "T," the highest powered shaft driven car built.
Price, \$3,500.00.

THE same attention to mechanical detail, the same care devoted to materials and style and luxury and convenience that has marked Haynes Models for the past thirteen years, is found in those of the coming season.

Exclusive mechanical features in 1907, as in 1906, make it the car of maximum road performance, dependable, reliable, the car the repairman seldom sees.

Send at once for full information and advance specifications, addressing Desk H 1.

In New York we shall exhibit at the Seventh National Automobile Show, Madison Square Garden, January 12-19, 1907.

*Oldest Automobile Manufacturers in America
Members A. L. A. M.*

**HAYNES AUTOMOBILE CO.
KOKOMO, IND.**

NEW YORK: 1715 Broadway

CHICAGO: 1420 Michigan Avenue

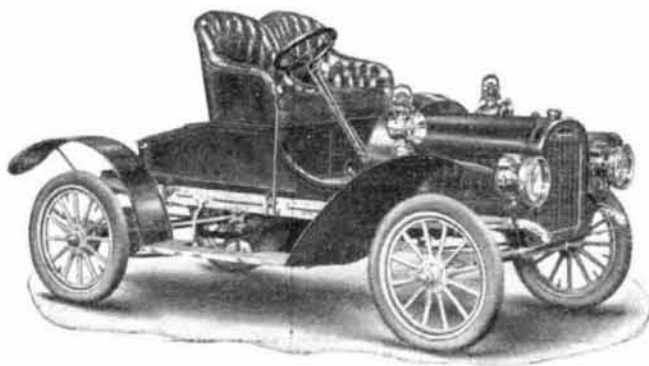

Model 27, Price \$950.

Equipped with acetylene head lamps with separate generator, oil tail lamp, and 6-volt 60-ampere storage battery, \$1,000.

The ideal qualities of a touring runabout are reached in the Rambler Model 27.

In this is embodied the new Rambler unit power plant comprising a double opposed horizontal motor, planetary transmission and multiple disc clutch entirely enclosed with three-point support.

No moving part of the motor or transmission gear is exposed, and every part is entirely accessible from above.

You will not appreciate the many valuable features of this model without our new catalogue containing complete description of this and other 1907 models. Mailed upon request.

Main Office and Factory, Kenosha, Wis., U. S. A.

Branches:

Chicago Milwaukee, Boston, Philadelphia, San Francisco.
New York Agency, 38-40 W. 62nd St. Representatives in all leading cities.

Thomas B. Jeffery & Company

A NOVEL INDIVIDUAL CLUTCH TRANSMISSION.

(Continued from page 29.)

the end of the sliding shaft, C, the ends of which press the internal expanding wedge, M, forward, thus causing the four wedge pins, K, to protrude beyond the periphery of the shaft, C, opening the frictions, AA, against the internal wall of the bronze ring gear, B. This action makes the whole mechanism integral. To change the speed the sliding shaft is simply located under any gear desired and the operation repeated. D is the differential from which the jack shaft, J, protrudes from either side, to the sprockets. The reverse is accomplished by an intermediate gear which is located in a pocket at the bottom of the case under another gear (which is shown as not in mesh and on the shaft, E.)

THE GROUT 35-HORSE-POWER CHASSIS.

(Continued from page 31.)

tion is by accumulators and a single spark coil. The high-tension distributor is combined with the commutator, C, which is operated by a lever in the steering wheel. The muffler appears at M. The engine and transmission are mounted on an angle steel sub-frame, as shown.

Lever A and B operate the three-speed progressive sliding-gear transmission and the expanding emergency brakes on the rear wheels. The former lever is connected through the horizontal lever, D, with the sliding rod, R, that extends into the gear case, and shifts the gears, while the latter lever, B, when drawn toward the driver, applies expanding brakes in the rear wheels. The pedal, E, operates the contracting brakes on the rear wheel hubs, while the pedal, F, controls the clutch, which is of the ordinary leather-faced cone type. There is a large universal joint, U, between the clutch and the gear box, and the countershaft is provided with Oldham universal couplings between the gear box and the frame. One of the driving sprockets on the countershaft is seen at J. A cylindrical gasoline tank of 15 gallons capacity is placed under the front seat, and the pipe, P, extending from its lowest point to the carbureter, feeds the latter by gravity.

THE NORTHERN FOUR-CYLINDER 50 HORSE-POWER CAR.

(Continued from page 34.)

son, the Northern Motor Car Company has placed on the market a 50-horse-power car embodying all the essential features of the air control. Clutch and air control features remain practically the same as last year, with the exception that the parts are increased in proportion to the larger car, which is rated at 50 horse-power.

It will be noticed that the entire control is placed on the steering column, and that all side levers are omitted. The gear-shift lever is placed horizontally just below the steering wheel, and the small lever which operates the shift gears controls the clutch. A slight turning motion of the hand grip on this lever throws in or releases the clutch. It will be seen that practically the same motion that shifts the gears operates the clutch at the same time. The reverse operation is taken care of with the right foot by pressing on a pedal projecting from the steering column. This reverse position is interlocked in such a way that the reverse can only be operated in a certain position of the gears. The transmission is placed on the rear axle. It is very compact, and runs on roller bearings of the Timken type. Easy adjustment and accessibility are marked features of this arrangement. Ball bearings are provided for the steering spindles as well as the worm and segment mechanism, which renders steering very easy.

Special attention is directed to the pivotal rear platform spring, which permits of either of the rear wheels passing over an obstruction without imparting any shock to the car frame. It will be

(Continued on page 56.)