

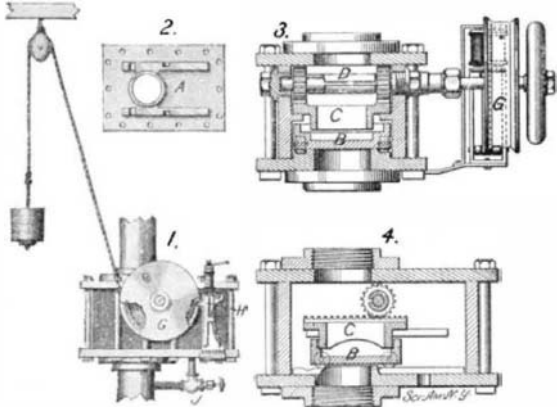

**SAFETY STOP VALVE.**

The accompanying engraving illustrates a valve provided with mechanism whereby it will automatically close when predetermined conditions take place. The invention is particularly applicable to steam pipes,



**SAFETY STOP VALVE.**

though it will be equally efficient for use with pipes carrying any other fluid. The device comprises a valve casing, provided with inlet and outlet pipes. The bottom of the casing consists of a plate such as is shown in Fig. 2. The plate is formed with a valve seat and a pair of tracks. The purpose of these tracks is to support the wheels of the valve, B, which is best shown in the section, Fig. 4. The tracks are formed with depressions to receive the wheels and permit the valve to drop onto the seat when it is directly over it. The forward wheels of the valve are broader than the rear wheels and will, therefore, pass over the depressions for the latter without sinking in. The valve, B, is of box form, and is open at the top to receive a downwardly extending projection of the slide, C. The latter is formed with a rack at each side on its upper face, and these are engaged by pinions on a shaft, D. The shaft carries a drum, G, on which a rope is adapted to be coiled. An end of the rope passes over a pulley and is attached to a weight. The weight, when it falls, turns the drum and with it the shaft and pinions, thereby moving the slide, C, toward the valve seat. The slide, C, carries the valve, B, with it, but does not drop with the valve when the valve seat is reached, because it is supported on rails formed on the sides of the casing. Normally the weight is prevented from falling by a trigger, H, which engages a notch in the periphery of the drum. The armature of an electro-magnet locks the trigger, but when the magnet is energized the armature is raised and the trigger is sprung, permitting the weight to fall and close the valve. The shaft, D, is provided with a handwheel by which the valve may be operated by hand. A by-pass is provided beneath the casing whereby steam may be admitted to both sides of the valve and, by thus equalizing the pressure, permit the valve to be opened easily. Mr. C. W. Nicholson, Box 399, Roslyn, Wash., has secured a patent on this improved valve.

**AN IMPROVED ANIMAL TRAP.**

We illustrate herewith a novel trap invented by Mr. C. T. Owens, of Hominy, Oklahoma Territory. This trap will, according to its size, be adapted to

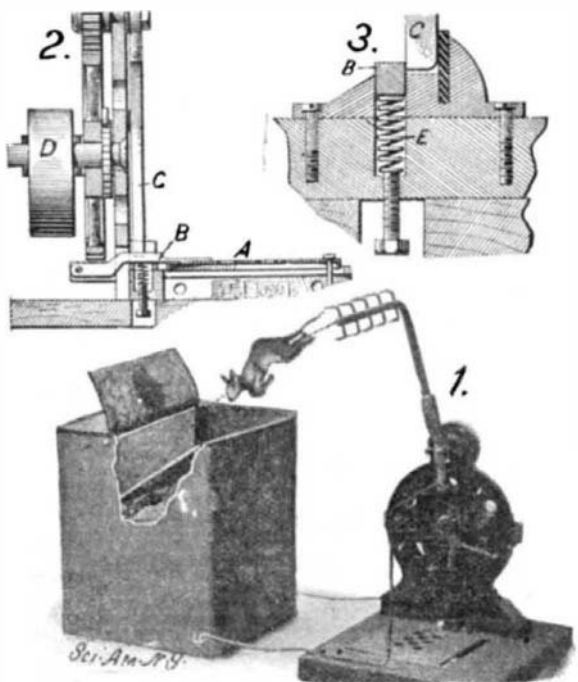

**AN IMPROVED ANIMAL TRAP.**

catch any undesirable animals, such as mice, rats, wolves, etc. Its chief claim to novelty lies in the fact that it not only catches and kills the animal, but also removes it to sufficient distance to prevent any interference with the subsequent operation of the trap. The trap is spring-actuated and after each operation of catching an animal it automatically resets itself for the next victim. It is thus effective for killing a large number of animals without any attendance whatever, until the actuating spring is run down. It will then merely be necessary to rewind the spring, when the device will be ready for its next series of operations. In Fig. 1 of our illustration we show a general view of Mr. Owens's rat trap in operation. The construction of the device will best be understood by reference to the detail views, of which Fig. 2 is a vertical section through the axis of the trap. The device comprises a tread, A, supported by a lever, B, which rests on a spring, E. The lever, B, serves as a detent for trigger, C (as best shown in the cross-section Fig. 3), which engages the lower end of a pivoted spiked arm. A heavy clock spring, D, acts through a series of gears to communicate a rotative tendency to the spiked arm. However, the arm is prevented from turning by the detent, B, engaging the trigger, C. In use bait is set on the tread, A, and when a rat, in attempting to reach the bait, presses down the tread even a slight distance, the trigger will be freed and the spiked arm will sweep rapidly around and across the tread, impaling the rat. At the same time a spring on the trigger will return the latter to its normal position, and the spring, E, will raise the lever, B, thus locking the trigger, so that when the spiked arm has made a complete turn its motion will be abruptly arrested by the trigger and the animal it carries will be slung off. To insure the death of the rat, for it might only be wounded by the spikes, a can of water is placed at a proper distance to catch it as it is slung off the trap. The can is provided with an inclined wall leading to a swinging vertical shutter through which the rat will slide into the water and be drowned.

**Brief Notes Concerning Inventions.**

The blowing of electric-light bulbs at the present time is done by hand, and the operation is therefore slow; but a piece of machinery to do this work has been recently patented by a mechanical engineer of Toledo, Ohio. One of these machines has been experimentally constructed with four blow irons, and shows a capacity of over seven hundred bulbs per hour, but it is proposed to increase the number of blow irons to six or seven, and this will add to the output correspondingly. The necessary amount of compressed air is furnished automatically. The hot glass is thrown on the blowing irons, and as they revolve, the molds close around them, when the blowing proceeds. After the material has had a chance to cool sufficiently, the mold is opened, and the bulb dropped out into the cooling liquid. The machine is said to reduce the cost of bulb production to one-quarter the present figures. The apparatus is said to be also valuable for blowing lamp shades and similar articles.

A complete revolution has been recently made in the manner of applying gold leaf to books and other similar articles. The bookbinder at present is compelled to make use of dies in the shape of type and other forms used for ornamentation. These must be made of brass and are cut by hand, so that they are quite expensive, and a suitable assortment represents a large investment. With the use of these devices the decorative possibilities were limited to a great degree, and the process was a very tedious one. Through a recent patent there is disclosed a new process, which removes the limitations, and the application of the gold or other metal leaf is done through the medium of the pyrographic pencil, such as is at present made use of for burning wood and leather. Some slight changes are made in the point used, so that instead of the latter being maintained at a white heat it is kept at a much lower temperature, which is necessary for the success of the operation. The leaf is taken from the book in which it is sold by causing it to adhere to a piece of paraffin paper. Thus it is transferred to the point of application with the paraffin paper on top. The heated point is then passed over the latter with a slight pressure, and upon removal of the paper the leaf will be found firmly fixed to the article as desired. In this manner it will be possible to make a reproduction of a signature or certain designs, which could not be accomplished by the old process.

**A PORTABLE HEAD GATE.**

A simple portable head gate has recently been invented for use in open ditches and laterals which can be adjusted to any shape or size of ditch within predetermined dimensions. The head gate is provided with a waste gate that will allow any water to pass that may be needed further down the lateral. The waste gate is so located that no water passing therethrough will wash around the main gate. The device comprises two plates, one of which is movable on the other. The relatively fixed gate is shown in detail in Fig. 3. One

side of the plate is cut away to provide an opening for the waste flow. The plate is mounted on a post whose pointed end projects below the lower edge of the plate. The second, or movable plate, is of the same general form as the first one without being cut away at the side. The movable plate is secured to the fixed one by bolts in the latter which pass through slots at the top and bottom of the former. The upper slot is quite long and is curved to permit the plate to be swung on the lower bolt as a center. Owing to this slotted connection, the plate can be adjusted either by prying it or moving it bodily sideways to adapt the head gate for any desired form or size of ditch within limits.

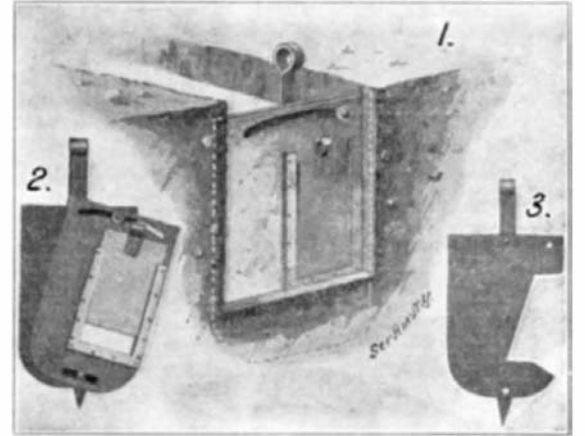

**A PORTABLE HEAD GATE.**

The movable plate is provided with an opening which is normally closed by a gate adapted to slide in ways on the plate. The gate serves as a waste gate and is preferably placed at one side of the center so that when the water passes through the opening it will not have a tendency to work around the gate proper and disturb its position. The inventor of this improved head gate is Mr. U. F. McBurney, Boise, Idaho.

**WOODWORKER'S CLAMP.**

An improved clamp, more particularly designed for the use of carpenters, cabinetmakers, and other woodworkers, has recently been invented by Mr. Emil Hillebrandt, of 91 Cottage Street, Buffalo, N. Y. This clamp is arranged to permit quick and convenient adjustment of the jaws, to securely clamp pieces of wood that are to be glued together. The clamp comprises a shank terminating at one end in a fixed jaw. Mounted to slide on the shank is a movable jaw, A. Mounted on this movable jaw is a pawl, B. The latter is formed with ratchet teeth which are adapted to mesh with teeth on the shank when the jaw, A, is locked in position. The pawl is normally pressed by a spring against the shank, but is provided with a handle whereby it may be withdrawn whenever desired. Bearing against the opposite side of the shank is a cam, C, which is journaled in the body portion of the jaw, A. In use, the work to be clamped is placed against the fixed jaw, and then with a cam turned upward, as shown in Fig. 1, the movable jaw may be pressed snugly up against the work, the pawl, B, moving up idly with the jaw. After the jaw has been adjusted it is locked by moving down the cam lever, C, to the position shown in Fig. 2. It will be noticed that the cam draws the jaw, A, bodily toward the shank, but that it moves on the toothed pawl as a fulcrum and that as this is lower than the point where the cam engages the shank, the jaw is swung upward and into closer engagement with the work. To release the device the cam lever is swung up and the pawl drawn out of engagement with the teeth on the shank, as shown by dotted lines in Fig. 1.

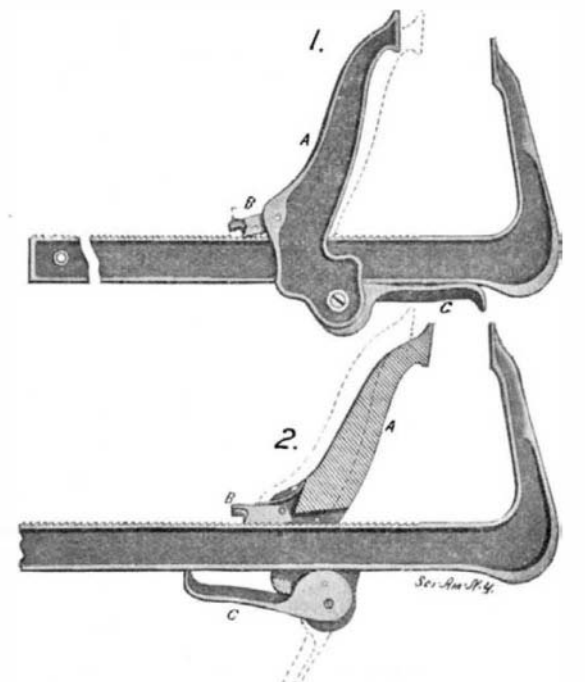

**WOODWORKER'S CLAMP.**