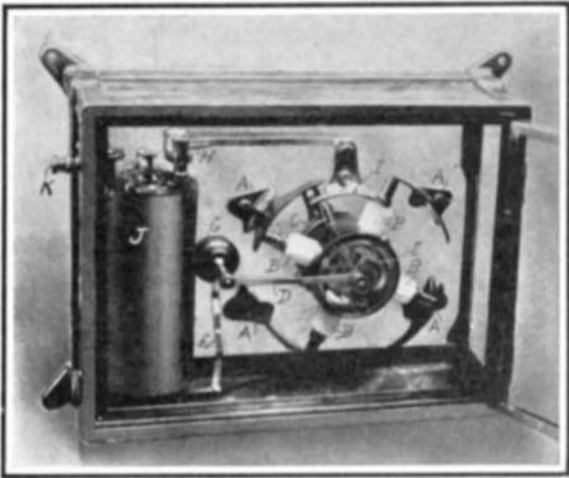

NEW SPRING WHEELS.*(Continued from page 36.)*

tire will run from 10,000 to 12,000 miles upon fairly good roads without needing repairs. The weight of the Guigner wheel is from 70 to 100 pounds, according to the size, and at present it is made in 30 to 38-inch sizes.

Another interesting effort to grapple with the problem of obviating the disadvantages inherent in pneumatic tires is the invention of Mr. George Middleton, of London. In this device, instead of the wheel rims being shod with pneumatic tires, the air cushion is inserted round the hub of the wheel, so that the wheel proper has no rigid connection with the axle or driving medium. This device has been thoroughly tested with a 15-horse-power Panhard car, the wheels of which

**A NOVEL DASHBOARD IGNITION OUTFIT.**

were fitted with it and shod with solid tires. Over 15,000 miles have been covered, and the system has proved fairly successful. The degree of resiliency is of course not equal to that of pneumatic tires, but it has the surety that a puncture is a very remote possibility. Should, however, the air cushion break down, the car can still be safely run to its destination where the defective tube can be repaired. Access to the tube can be effected quickly and easily since the outer flange is made removable for this purpose. Several high-powered cars have already had this pneumatic hub fitted to the driving wheels, so that the latter can be shod with solid tires, and the conversion has proved completely successful.

A wheel having a hub somewhat similar to the above-described wheel, but in which the hub is supported on springs instead of on a pneumatic tube, is also shown at the bottom of page 36. This wheel is provided with a solid tire put on in sections, which are held to the rim by special binding screws. The arrangement is a compact one and it has a very neat appearance.

A somewhat more complicated wheel, designed for a like purpose, consists of a hub tied by tangent spokes

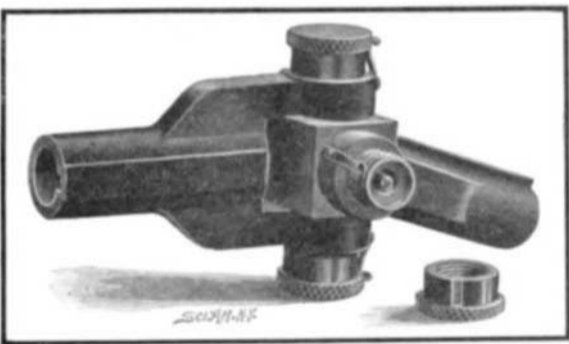
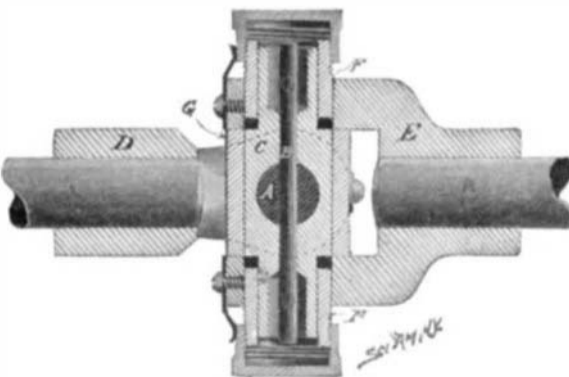
**Fig. 1.--UNIVERSAL JOINT ASSEMBLED.****Fig. 2.—SECTION THROUGH JOINT.**

to a ring surrounded by an annular coiled spring, and situated within the rim of the wheel. This ring is straddled by twelve radial rods connecting the rim of the wheel with a metal ring surrounding the hub, and these rods also have coiled springs acting under compression. The inner ring having the annular coiled

spring may be considered an inner driving wheel, for as the axle begins to turn, the spring is compressed against the radial rods or spokes, thereby giving a spring-drive to the rim. The straight coiled springs which run to the rim act as shock absorbers or spring cushions which take the place of pneumatic tires.

Roman Antiquities Discovered in London.

Another section of the ancient Roman wall has been brought to light during the construction of a factory in the City of London. The unearthed relic measures 20 feet in length by 7 feet in height. Owing to its extreme antiquarian interest, the wall is not to be demolished, but is to be left in position, the new factory being built around it. It will then project about three feet into one of the rooms on the lower ground floor. To protect the wall from crumbling under the vibration of machinery and other causes, it is to be inclosed in a galvanized-iron netting similar to that around the Roman remains at the London Coal Exchange. In the course of other excavations upon the site for a fire station in Cannon Street, a Roman bath was unearthed. The relic is in a perfect state of preservation and is quite complete. It measures inside 10 feet 6 inches in length by 6 feet 3 inches wide, and weighs about seven tons. This monument has been removed intact, and will eventually be placed in a museum.

A DASHBOARD IGNITION OUTFIT.

In the Mosler ignition device, illustrated herewith, all parts of the electric system of an automobile except the batteries, spark plugs and connecting wires, are carried in a brass-framed glass case attached to the dashboard. The case contains the coil, a primary interrupter, and a secondary distributor, and these are always visible, thus permitting adjustments and repairs with little loss of time.

The wire from the batteries connects through the binding post, *K*, with the primary of the coil, *J*, while the other end of this winding is joined through the contact, *H*, with the fixed sector, *I*, on the rear wall of the case, *I* being connected through the brush post, *C*, with the four segments of the primary interrupter. The primary circuit is completed through the grounded shaft and car body to the batteries.

One terminal of the secondary coil winding is grounded through the same post as the primary, while the other connects with a brass strip, *F*, carried by the hard rubber support, *G*. From this current is carried to a central terminal, *E*, of the distributor by a movable flexible rod, *D*, which is so hinged at the bracket end that it can be swung from the terminal, *E*, to permit the opening of the circuit. The high tension circuit from *E* is through revolving ball contact with the rotating T-shaped brush. The outer ends of the four high-tension terminals which are inclosed in the insulations, *B*, are in direct contact with the four segments, *A*. These are secured to the rear panel of the casing and are connected to the four wires to the spark plugs.

AN IMPROVED UNIVERSAL JOINT.

A universal joint has recently been invented, which is so designed that it can be taken apart without the use of tools. One of our illustrations shows the complete joint with one of the grease cups removed, while the other is a section which clearly shows the novel construction. It will be observed that the joint comprises a central cubical block, *G*, through which passes a shouldered pin, *C*. A hole is drilled transversely through this pin and the block to receive the pin, *A*. A small locking pin, *B*, passes lengthwise through the pin, *C*, and transversely through pin, *A*, serving to hold them together in proper relative position. The projecting ends of these pins find bearings respectively in the forks, *E* and *D*, which are carried on the two sections of the shaft. Bushings, *F*, are driven into the holes in the forks, and the threaded ends of these bushings carry the grease cups. Spring stops on the forks press against the cups to prevent them from working off the bushing. Packing rings at the bottom of the bushings prevent the escape of the lubricant, which is kept in holes drilled in the ends of the pins, *A* and *C*. When it is desired to take the joint apart, two adjacent grease cups are removed. The pin, *B*, is then removed, permitting the pin, *A*, to drop out, whereupon the joint falls apart.

WHEEL CLUTCH FOR USE WITH A SOLID REAR AXLE.

Many attempts have been made by inventors to devise some sort of a clutch for use on the rear axle of an automobile, which would do away with the complications and deficiencies of the differential gear. We illustrate herewith a simple clutch which appears to have solved the difficulty. The rear axle turns on roller bearings, carried by the housing, 1. The sleeve, 2, on this housing carries a friction band, 3, which is mounted on the hub of the nut, 4, and is free to move in and out with this nut. The nut engages a thread on the axle. It will be observed that the periphery of

the nut is formed with inclined faces adapted to engage one or other of the clutch faces on the hubs, 5 and 6. The illustration shows the nut engaging the "go-ahead" clutch, 5. If, as in rounding a curve, the outer wheel travels faster than the axle, it tends to feed the nut out to a neutral position between the two faces. When the motion of the axle is reversed, the thread feeds the nut back against the clutch, 6, and then again, if the wheel travels faster than the axle, the clutch feeds the nut in far enough to disengage the clutch faces. As a result of this construction, the wheel which is doing the harder work receives more power, whereas with a differential axle the wheel which is doing the less work is favored at the expense of the other. An extreme example is that of a machine equipped with a differential axle standing

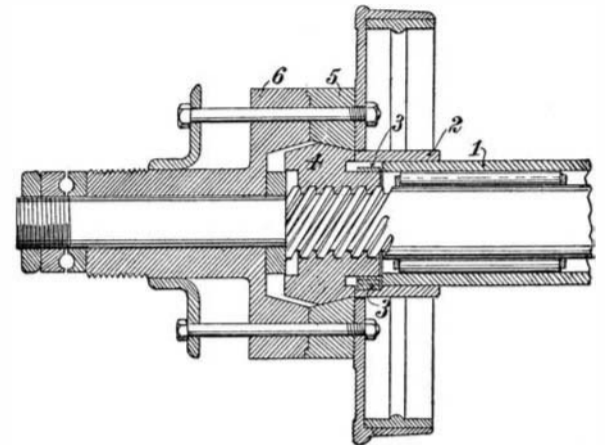
**AUTOMATIC WHEEL CLUTCH MAKING POSSIBLE A SOLID LIVE AXLE.**

with one wheel on dry pavement and the other on a muddy or wet spot. The latter wheel will spin idly around while the other remains stationary. The improved axle here shown would make both wheels turn at the same speed, expending the greater power on the wheel which engages the dry ground.

THE THOMAS SAFETY RATCHET DEVICE.

One of the most striking features of the Thomas car is a safety ratchet device arranged on the brake drums of the rear wheels and having for its object the instant stopping of the machine should the brakes fail to hold and the car start to run down hill backward. By the movement of a small lever placed on the dash, the driver rotates the rod, *D*, and, by means of the connection, *B*, draws up the pawl, *C*, against the ratchet-toothed ring, *A*. *C* is held against *A* by means of a spring suitably connected in the system, with the result that if the car is backing, it is instantly brought to a standstill and its passengers are saved from disastrous results. This device is a valuable one, and should be placed on more of the large touring cars, as failure of the brakes in a critical moment is one of the troubles to which such cars are prone. The

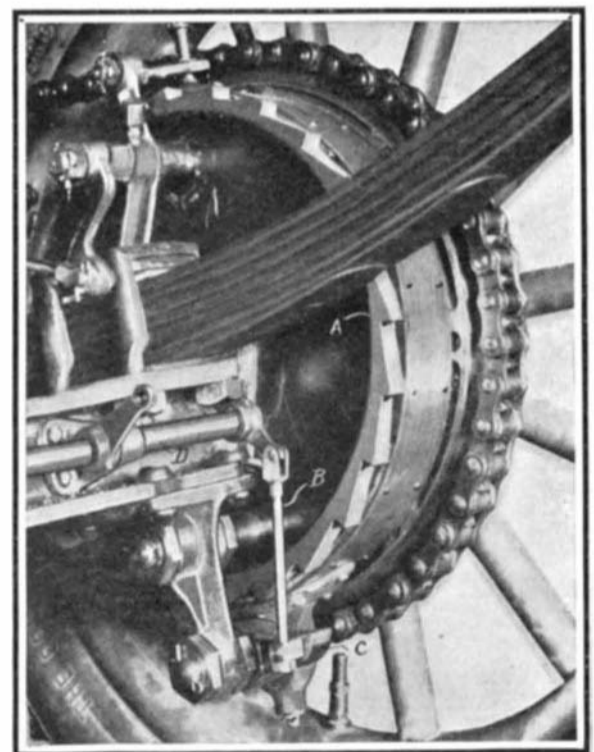
**THOMAS SAFETY RATCHET DEVICE FOR STOPPING A CAR FROM BACKING DOWN HILL.**

1906 Thomas is as commodious a car as heretofore. It has a 5½ x 5½, 4-cylinder, 50-horse-power motor, 34 x 4½-inch tires, a 118-inch wheel base, and weighs in the neighborhood of 3,000 pounds. Every car is sold under a guarantee that it will develop a speed of 60 miles an hour.