

#### TURRET COAL BIN FOR LOCOMOTIVE TENDERS.

A recent patent describes a new type of coal bin for locomotive tenders which offers the advantage of holding the coal always within easy reach of the cab, so that the necessity of dragging down the coal is avoided. The bin consists of a large drum provided with a central pivot pin which turns in a socket bearing in the floor of the tender. It is also supported by rollers traveling on tracks on the tender. The drum carries along its lower edge a peripheral rack which is connected by a train of gearing with a hand wheel. The latter may be operated to rotate the bin on its pivot to any desired position. The bin is divided by a cen-

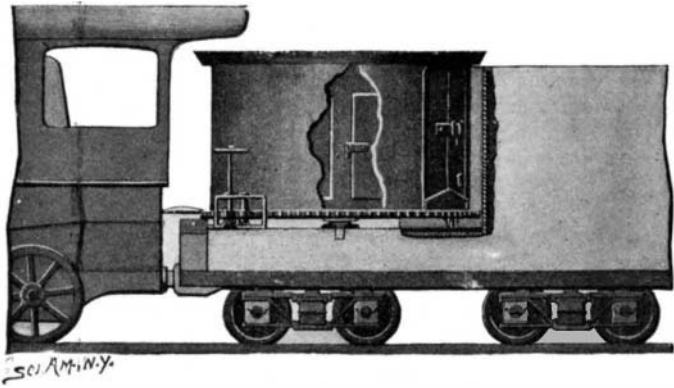

TURRET COAL BIN FOR LOCOMOTIVE TENDERS.

tral vertical partition into two compartments. Each compartment may be entered through double doors opening inwardly. These doors are cut away at the bottom, forming a triangular opening through which the coal may be shoveled out. A vertically swinging gate is provided for closing this opening when desired. When all the coal within easy reach of this opening has been shoveled out the doors of the bin may be opened to gain access to the rest of the coal. As soon as one compartment is emptied, the hand wheel is operated to turn the bin around until the other compartment is brought into convenient position for shoveling out the coal. Our illustration shows the bin partly swung around. In the central position of the bin there are two doors which may be used in case of emergency. If, for example, an accident should occur which would prevent turning the bin, coal could be drawn from the filled compartment through one of these doors. The doors are arranged to open on opposite sides of the partition, so that no matter which compartment is filled it can be entered from the other compartment by one or the other of these doors. The inventor of this coal bin is Mr. C. C. Collette, 928 Florida Street, Springfield, Mo.

#### IMPROVED DUMPING CAR.

The accompanying engraving illustrates an improved dumping car invented by Mr. Herman Peiler, of Koloa, Kauai, Hawaii. Box 20. The car is so designed that it may be tilted to either side desired and at such an angle that the entire load will be dumped. As shown in the accompanying engraving the car comprises a bed mounted on wheels and a body portion resting on the bed. The side walls of the car body are hinged at their upper corners so that they can swing out to release the load when the car is dumped. Normally these sides are locked in closed position by means of hasps which engage eyes mounted on the main part of the car body. The arc-shaped pins which lock the hasps are attached to a rock shaft passing through the car body. The positions of the hasps on opposite sides of the car are such that when the shaft is rocked in one direction, one of the hasps will be unlocked, and when rocked in the

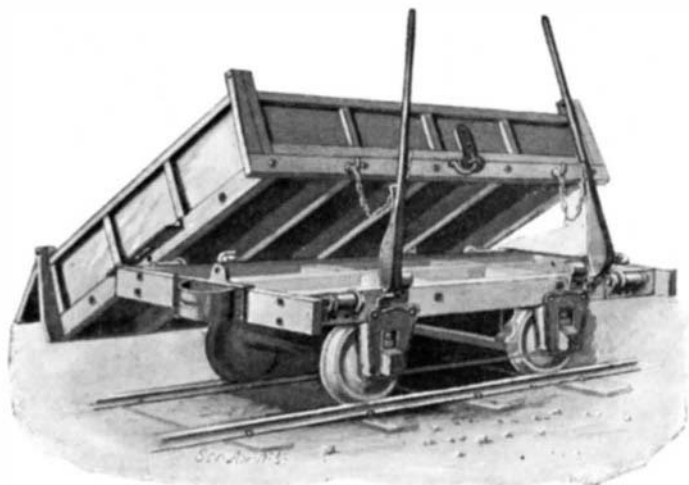

IMPROVED DUMPING CAR.

other direction the other will be unlocked. Mounted on the bed under the ends of the car body, are rollers which, however, do not engage the body except when the latter is tilted. A pair of levers of special design are provided for tilting the car body, when the latter will roll sideways until arrested by pivot pins thereon engaging arms secured to the side sills of the car bed. Before tilting the car body the rock shaft should be operated to release the desired hasp so that the corresponding side wall will be free to swing out and permit dumping the load. After the load has been dumped the car body is attached with chains to the levers which are drawn back to return the parts to normal position. The car body is centered on the bed by means of socket pieces which slip over studs secured to the car bed, and in this position it is locked by pins which pass through the studs and into the body of the car.

#### Brief Notes Concerning Patents.

A so-called "improvement" in devices for preventing collisions, accidents, etc., by railway trains has recently been invented. It consists essentially in a folding framework, known as a "lazy-tongs," the rear end of which is connected to a locomotive in such a manner that by operating a lever the framework may be folded or extended, so that the forward end will extend a considerable distance ahead of the train. Trucks support the framework at intervals, and are secured to the pivotal points of the levers making up the framework. The forward truck is provided with a buffer-bar, springs being interposed between this bar and the truck frame. An electrical alarm sounds within the engine when the bar comes in contact with any resisting body. The impossibility of this device performing the objects of its inventor would be apparent if one considers for a moment the force of impact due to the momentum of so large and swiftly-moving a body as a railway train. Even if the buffer device were sufficiently long and afforded resistance to any appreciable effect in reducing the speed of the train, the inertia of the joints could not be overcome with the needed rapidity for their response to the collision, and as a consequence, the wreck would be materially increased by the number of members in the "lazy-tongs."

An infringement suit has been brought against the management of the Louisiana Purchase Exposition, involving the invention of the identification card, which was made use of in the shape of passes to the late show. The patent covering the identification card was originally granted to B. L. Behrendt, of Chicago, Ill., and is now controlled by the Fraternal Identification Company of America.

A new type of berth, the object of which is to overcome seasickness, is in course of experiment upon two of the steamships plying between Dover and Calais. The berth is the device of a London dentist. The apparatus comprises a swinging cot suspended in a steel framework by four cords passing through electric brakes, which automatically maintain the bunk in a horizontal position, no matter how much the vessel may roll. The berth is fitted with a water mattress and an electric fan.

#### AN IMPROVED DITCHING MACHINE.

An economic and effective machine for making ditches for the purpose of under-draining land with tile, slate, etc., has been provided by the recent invention of Mr. Walter Umstead, of Jerseytown, Columbia County, Pa. The machine is arranged to be conveniently raised or lowered, so that the ditch may be carried to the desired depth by successive operations without undue strain on the team. The parts are so designed as to cut a straight, clean ditch, sweeping the dirt away from the edges. As shown in the accompanying engraving, the beam, A, is secured to the arched axle of the machine and carries the tongue at its forward end. This beam is made of channel iron, and at the rear end, between the side flanges, a pinion is mounted. The latter may be operated by a crank handle to raise or lower an inclined rack bar with which it is in engagement. The bar is held against the pinion by friction rollers mounted on a swinging yoke-piece, as illustrated. At its lower end the bar is hinged to a horizontal head bar, F, which carries a vertical standard against which the shank, B, of the plow is secured. Between the edge of this standard and the plow shank an L-shaped groove is formed into which a tongue on the clearing wing, C, is fitted. The wing thus has guided movement in a vertical direction. A coil spring, D, presses it down so as to hold it in engagement with the surface of the ground. The wing, C, is formed with a plate which curves over and in front of the plow shank so as to catch the soil that is turned up

and guide it off to the side of the ditch. Directly in front of the plow are a pair of cutter plates, E, designed to cut the turf and any roots that may be encountered and to smooth off the sides of the ditch. It will be observed that the left-hand plate is considerably in advance of the other. In use the crank is turned to lower the plow and cutters to the required extent, while the clearing wing adjusts itself under pressure of the spring against the surface of the ground. It will be observed that the head bar, F, is connected by two links, G, to the beam, A, so that it will always lie horizontal no matter if swung up or down. The draft attachment is made close to the cutters, E, and the neck yoke is free to slide on the tongue

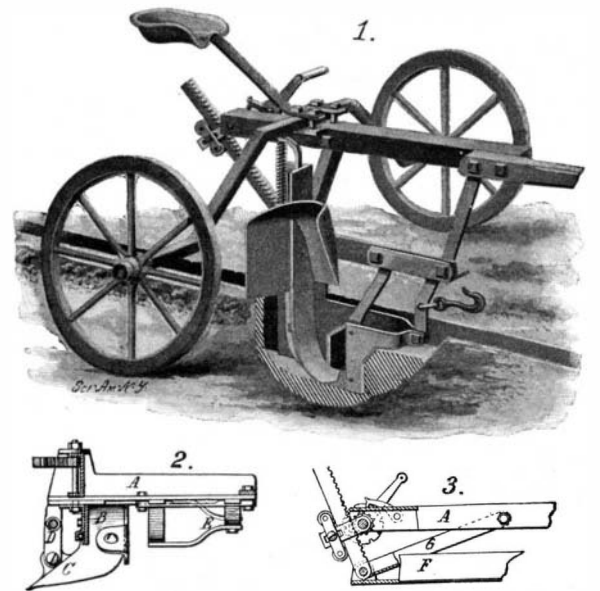

AN IMPROVED DITCHING MACHINE.

so that it will adjust itself to different positions of the head bar. After the ditch has been cut the plow and cutters may be raised clear of the ground by operating the crank handle.

#### A PUNCTURE-PROOF TIRE.

A very interesting solution of the tire problem is offered by the recent invention of Mr. Thomas W. Ranson, Jr., of 135 North Perry Street, Cleveland, Ohio. In Mr. Ranson's vehicle wheel the tire is not placed on the outer periphery, but within a protecting rim of steel, so that the desired pneumatic cushion effect will be secured without exposing the rubber tube to the slightest danger of puncture, or to any great amount of wear. To furnish a certain degree of elasticity, and provide the requisite grip of the tire on the ground, a band of solid rubber is set into the steel rim. The steel rim is indicated at A in the engraving, and at B may be seen the solid rubber band. The rim, A, is attached to a steel ring, C, which is of inverted channel form, the side flanges projecting inward within a pair of face plates, D, bolted to the sides of the felly. Between these plates on the felly is a retaining ring of solid rubber, provided with a V-shaped outer periphery, in which the pneumatic tube is seated. The latter presses outward against the channel ring, C, but will give at the tread, permitting the ring, C, to slide within the plates, D, and producing the pneumatic cushion effect. The retainer and the tube are attached to the felly by means of a number of tire bolts. If, for any reason, the pneumatic tube should become deflated, the wheel could still be used by passing bolts through the holes in the channel ring just outside of the face plates, so that the ends of the bolts would rest on the edges of the face plates and hold the steel rim, A, concentric with the rest of the wheel. This, of course, sacrifices the elasticity of the tire to a large extent, but is of little consequence in cases of emergency. The construction of the tire is also advantageous for another reason, namely, that in guiding the vehicle around sharp corners, there is no probability of the tire being thrown off, as happens with many constructions now in use.

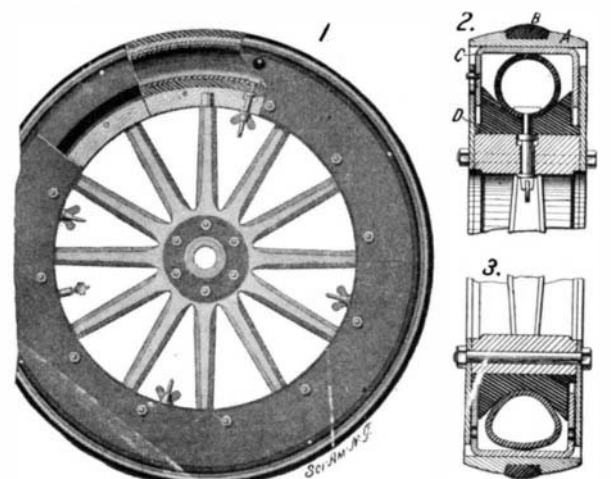

A PUNCTURE-PROOF TIRE.