

### A SIMPLE BURGLAR ALARM.

Dwellers in flats or apartments have a particular dread of sneak thieves, and have long felt the need of some simple alarm which would give notice of the unauthorized opening of the door, or even the trying of the door knob. A patent has just been granted to Mr. Amos Getto, of 873 Second Avenue, New York city, on an alarm which should meet these requirements. The alarm is illustrated in the accompanying engraving. It consists of an electric bell and battery formed with a hanger strap which is pivoted to a plate clamped by means of a thumb screw to the door knob. The battery, which is preferably a small dry-cell, is carried in an aluminium case at the back of the bell, and may be easily removed when desired, by drawing out the rod which extends across the open bottom of the case. One pole of the battery is electrically connected to one terminal of the bell, through the switch shown at the bottom of the bell. The other pole of the battery connects with a contact piece mounted on, but insulated from the hanger strap. The plate on which this strap is pivoted is provided with two prongs, as shown in the detail view. When the door knob is turned, it swings the plate from the position shown in dotted lines to that shown in full lines, when it will be observed, that one of the prongs makes connection with the contact piece on the strap. The current is thus completed through the plate and pivot pin to the strap, which is connected to the other terminal of the bell. It will thus be seen that when the switch is closed, whenever the door knob is turned to the right or left, it will complete the circuit by means of one or other of the prongs on the plate, and thus ring the bell. As a burglar alarm, in order to continue the ringing of the bell, a pawl is provided which is adapted to slide in a slot in a plate. Normally the pawl rests in a notch at one side, as shown in the general view, but when in operative position, it rests on the pointed end of the hanger strap, so that when the alarm is swung by the turning of the knob, the pawl will slide down the slot, as shown in the detail view, wedging the end of the hanger strap to one side and holding the pronged plate and contact piece in electrical contact. It will be seen that the alarm is very simple and compact and may be very quickly attached to any door knob. Not only may it be employed on a dwelling house, but also in connection with safes, warehouses, and the like.

### A SEA VOYAGE ON LAND.

In the accompanying illustrations we show a novel amusement apparatus which, though adapted to travel on a track on land, is arranged to give the passengers all the sensations of a voyage at sea. The apparatus has the form of a boat, and in order to carry out the illusion, some flexible material such as canvas, painted to represent waves of water, is secured to the boat along the supposed water line, and stretches out for a certain distance each side of the boat. The canvas also serves the purpose of covering the mechanism which gives the boat the required rocking and pitching motion. This mechanism is clearly indicated in our detailed views of the apparatus. It will be observed that the deck of the boat is supported on a bracket *C*, mounted to turn in one plane on the shaft *D*, and in the other at right angles thereto, on the shaft *E*, which is journaled in the main frame. This universal joint connection allows for the rolling and pitching motion of the boat. A crank disk at the front of the boat is slowly rotated by an electric motor through suitable step-down gearing. The extension arm *F* on one of the universal joint members is oscillated by means of connecting rod *G*, and crank pin *Q*, on the crank disk. In this manner the boat is caused to rock slowly laterally, the extent of the list being determined by the position of the pin *Q*, which may be adjusted along a radial slot in the crank disk. The fore-and-aft motion of the boat is governed in similar manner by crank disk *I* and connecting rod *M*, which has ball-and-socket connection with the deck of the boat at *N*. The operator or pilot of the boat is seated on the platform which is supported directly by the main frame and he is, therefore, not subjected to the rocking and pitching movement of the boat. On this relatively stationary platform are the two controller boxes. One of these controls the motor which operates the

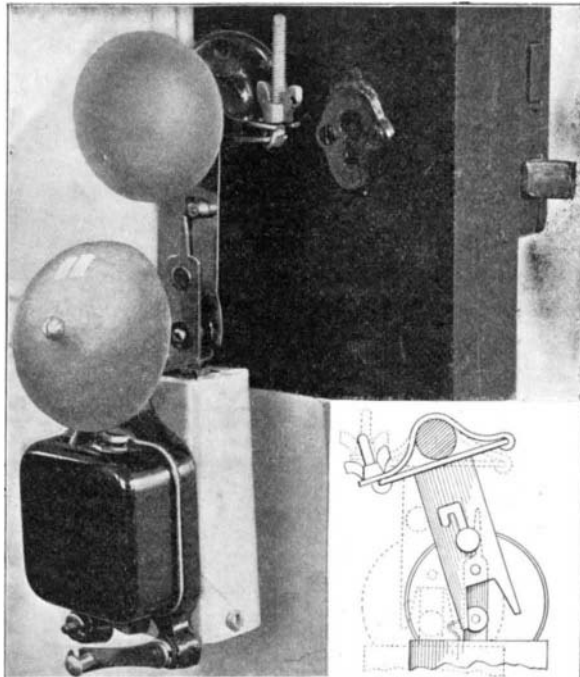

A SIMPLE BURGLAR ALARM.

rocking and pitching mechanism and the other controls the motor on the forward truck which propels the apparatus along the track. A couple of brake levers are also provided, one for quickly stopping the rocking motion, when desired, and the other for braking the motion of the truck. By using separate motors for propelling and for rocking the boat better control is had. The apparatus illustrated has been in operation for some time and has given very satisfactory results. The combined rocking and pitching of the vessel is

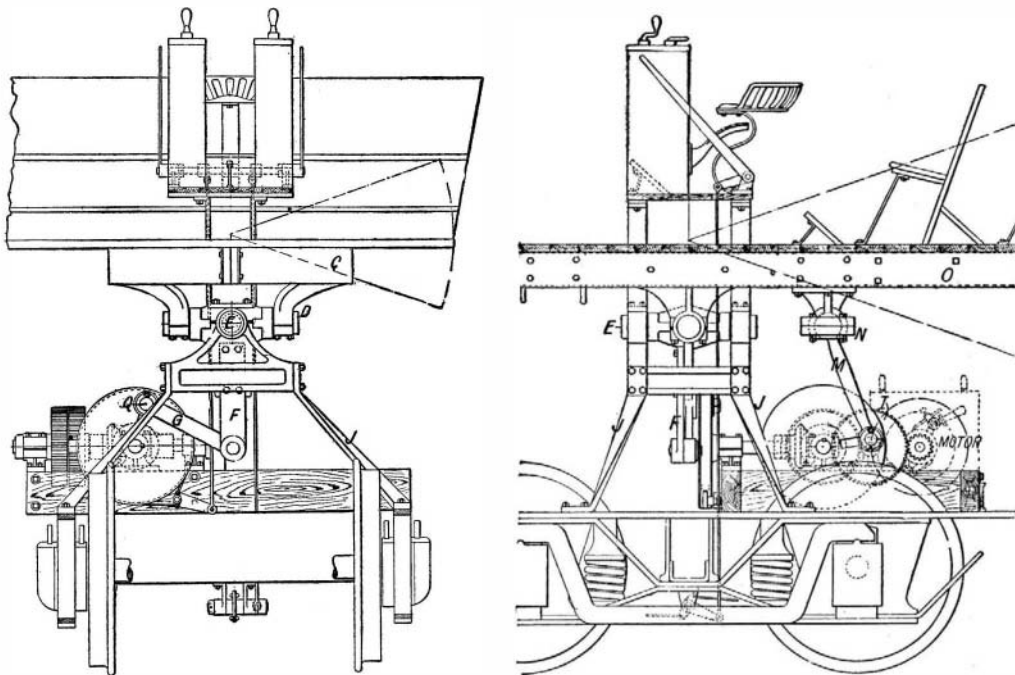

Front and Side Views of the Mechanism for Rocking the Boat.

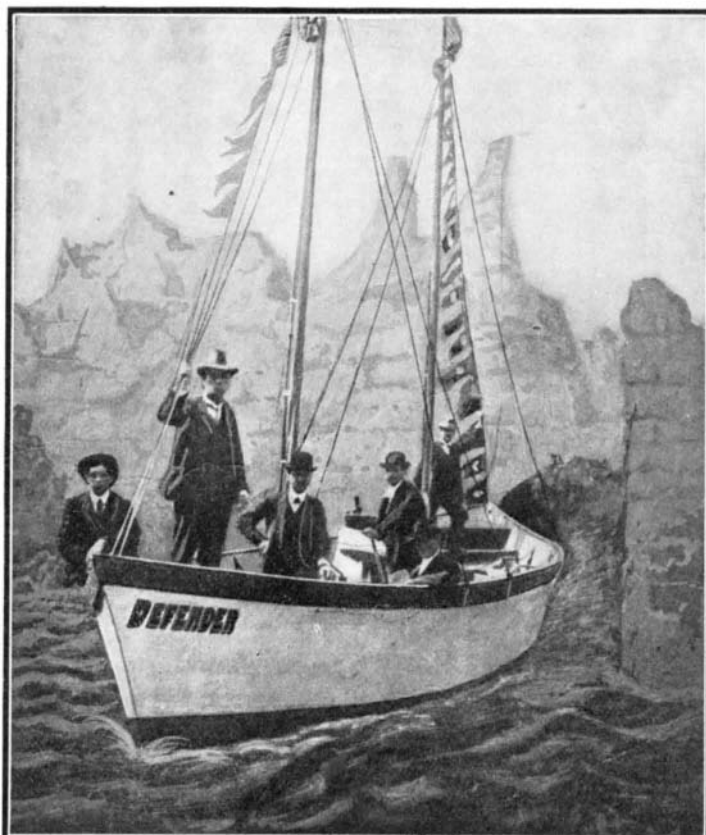

MECHANICAL BOAT WHICH SIMULATES THE ROLLING AND PITCHING OF A VESSEL AT SEA.

very realistic and closely simulates the motion of a vessel at sea. The patent on this invention has been secured by Mr. George W. Scofield, of 302 Broadway, New York, N. Y.

### The Toy Industry of Germany.

Some interesting particulars of the toy industry of Germany have been published by the British Consul at Hamburg. Toys constitute one of the most important branches of German manufacture. In the year 1903 the total volume of toys exported from all parts of the German Empire was 34,717 tons, valued at \$13,931,370. Though there is hardly any country in the world to which German toys are not exported the most important customer of Germany is Great Britain, which in the year under review received 12,218 tons. The second most important market for German toys is this country, the exports to which amounted in 1903 to 11,055 tons, valued at \$4,093,135.

The most important centers for the manufacture of toys in Germany are Nuremberg and Fürth in Bavaria, Sonneberg and some other parts of Thuringia, and the Saxon "Erzgebirge." Nuremberg, above all, has long been known throughout the world for its toy trade and industry; and German toys, wherever made, still go in many countries by the name of Nuremberg toys. At Fürth, which is close to Nuremberg, a flourishing trade and industry has likewise sprung up since about the end of the eighteenth century. Next to Nuremberg and Fürth, the town and district of Sonneberg has for many years enjoyed the best reputation for its toy industry and trade; while in the Saxon "Erzgebirge," a district comparatively poor in natural products, the manufacture of toys has likewise for some time furnished a source of livelihood to thousands of the inhabitants. The toys made at Nuremberg and Fürth are chiefly of the metal variety, made either of tin, tinned sheet iron, or of tin and lead alloys. Of the more than 200 toy factories established

in both of these towns, about 150 are devoted exclusively to metal toys; the only part of them worked by hand being the final painting, while all the rest is manufactured by machinery. In this respect this toy industry of the two Bavarian towns occupies a rather different position from that of all the other parts of Germany, where it is almost exclusively carried on by manual labor; that is to say, by workmen and women in their own homes. The success of the Nuremberg and Fürth metal toy manufactories is mainly attributable to the skillful manner in which the materials have been employed, and in which the machinery and tools used for the work have been adapted and gradually improved by the toy manufacturers themselves; thus enabling them to produce large quantities of articles within a comparatively short time, and to reduce the expenses of production, and in consequence also the sale prices of the articles manufactured by them.

### Cloth Made Fireproof.

United States Consul Frank W. Mahin sends from Nottingham, England, the following information relative to a new cloth fireproofing material:

"In a paper read at a meeting of a society of dyers in Manchester, titanitic acid (the oxide of titanium) was claimed to possess remarkable fireproofing properties, and evidence was produced in the shape of experiments by the reader of the paper. He took, for instance, some pieces of flannelette which had been treated with titanitic acid, and put a match to them.

"The incipient fire in the material smoldered and went out, refusing to burst into a flame. The experimenter claimed that all inflammable textiles could thus be rendered fireproof, and that dyeing, boiling, or washing would not remove the acid, it becoming, in fact, an integral part of the fabric."

A new electric resistance furnace, designed by a German, Herr O. Frölich, is built up of bricks of a material which conducts the electric current in the cold state about twenty-five times less than carbon, and hot, sixteen times less; it is not attacked by direct currents of usual voltages, and the melting point lies above 2,000 deg. C. The furnace temperature of such a jacketed furnace can be pushed above 1,600 deg. C.