

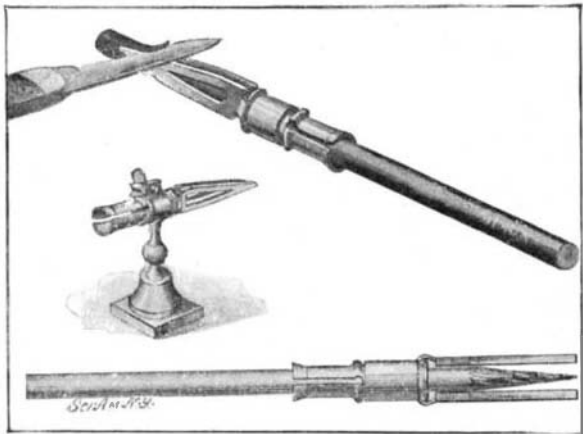

### DEVICE FOR USE IN SHARPENING PENCILS.

A rather novel invention is pictured in the accompanying engraving. It consists of a device adapted to assist in sharpening pencils accurately and quickly. It is usually held that the correct way to sharpen a pencil is to hold the point against the right thumb,



DEVICE FOR USE IN SHARPENING PENCILS.

and cut away the surplus wood and lead by drawing the blade of the knife toward the thumb. This method is open to the objection that it is apt to soil the thumb and fingers. On the other hand, the more cleanly method of sharpening a pencil by cutting outward, that is, away from the body, is apt to result in too deep a cut and the consequent breaking of the pencil point. The device here illustrated is adapted to provide against these objectionable features, permitting accurate sharpening of the pencil without in the least soiling one's hands. We show two forms of the device, one of which may be carried in the pocket, and the other mounted on a stand. In each case the device consists of a sleeve mounted to turn freely on a tubular member, which snugly fits the pencil. The sleeve is formed with projecting guide fingers tapered to the proper angle. In use the knife blade bears against the edges of the guide fingers, and is thus prevented from making too deep a cut in the pencil. The pencil is turned in the sleeve as a bearing after each cut so as to bring a new surface under the knife. The inventor of this device, Mr. A. D. Fagrelus, lives at 3106 Lucas Avenue, St. Louis, Mo.

### BLOW-OFF MECHANISM.

A patent has recently been granted to Mr. James M. Fagan, of 135th Street and Willow Avenue, New York city, on improvements in blow-off mechanism or valves for steam boilers. The invention provides a blow-off of simple and novel construction, so arranged that a main valve when closed will be submerged in clear water, thus reducing to a minimum the danger of de-

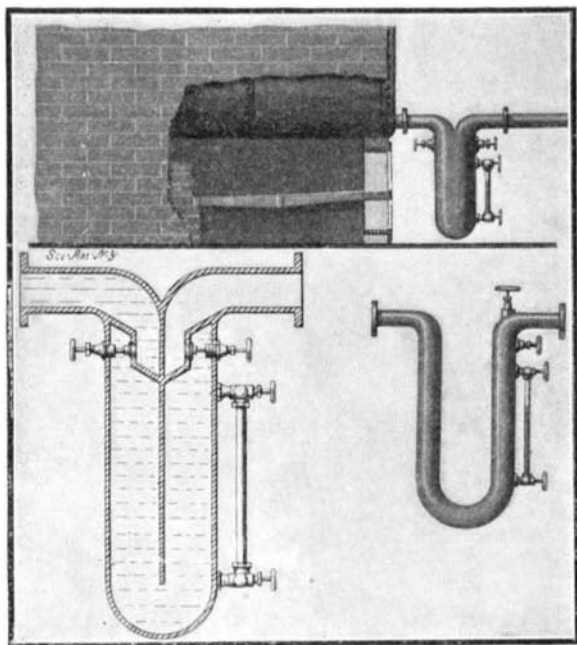

BLOW-OFF MECHANISM.

stroying the valve by the action of scale or sediment. Also the position of the valve is such that scale will not adhere to it when the device is in operation. As indicated in the accompanying engraving, and as shown most clearly in the lower left-hand view, the invention comprises a casing divided centrally by a partition, which extends from the top to within a short distance of the bottom of the casing. The casing is thus

formed with two water-legs, that at the left being termed the "inlet" leg, and the other the "outlet" leg. The latter is connected with an outlet pipe, and the former communicates with the boiler. Extended across the upper portion of each leg is a diaphragm having a vertical wall provided with a valve seat. The valve which is seated in the diaphragm of the outlet leg is the main valve, and the valve in the other leg is an auxiliary valve. In operation the main valve is opened wide, and the inflow is regulated by the auxiliary valve. In shutting off the flow the auxiliary valve is closed, and though some of the dirt and scale may be caught between the valve and its seat, it will not, however, cause sufficient leaking to prevent the operation of the device, or never enough to prevent the suspended matter in the water from settling to the bottom of the casing, leaving the main valve in clear water. The main valve can then be tightly closed, as the valve seat will be clean. The clearing of the water may be observed in a glass sight tube, communicating at the top and bottom with the outlet leg. We also illustrate a modification of the device, in which the water-legs are formed of a length of pipe bent to a substantially U shape. The auxiliary valve may be seated in a diaphragm extending across the upper end of the outlet leg above the main valve.

### New Car Replacer.

The Philadelphia Rapid Transit Company is at present conducting some experiments with a car replacer invented by Thomas Crawford, a resident of that city. The device has the advantages of being quite small and comparatively light, so that it can be placed on every car, or where the running time of cars is close, as in the cities, it can be at least placed on cars at more or less close intervals. For the purpose of placing a derailed car again on the tracks, a pair of implements is used much alike in design and general appearance. Each of these consists of two parts, the guide rail and the bridge. The former is a long tapering tongue with a groove extending along its length. The larger end of the guide rail fits loosely but securely in the other or bridge portion, which consists mainly of an inclined surface with its lower edge ending at the flange of the rail when the device is in place. The other of the pair has, in addition to the parts described above, also a lip by which it is held firmly in place when in use. The function of the guide rail is to direct the car wheel up onto the bridge, whereupon the wheel slides down the incline and falls into its proper place on the rail. Where the car has been carried some distance from the track, it is possible to work it back gradually by successive attempts, using the replacer until the wheel gets sufficiently close to the track to get the tongue under it and the other end of the replacer on the tracks. This device was given a number of severe tests by some of the officials of the company, and its operation was perfect in every case. The pair of implements which constitute one replacing set weighs but a trifle over fifty pounds. Their cost is but little.

### THE SCHEBLER AUTOMATIC CARBURETER.

An exceedingly compact and simple carbureter for gasoline engines is shown in cross section in the accompanying diagram. As can be readily seen, the carbureter consists of a float feed chamber, B, through which passes the air pipe, A C. The spraying nozzle, D, projects from the chamber, B, into this air pipe, and the U-shaped cork float, F, fits around it. The gasoline enters through the pipe, G, and the ball valve, N, which is on the end of a spindle that passes through and is secured to the float at Q, besides sliding up and down in the bracket, I. The valve is set to close when the gasoline has reached the level indicated. K is a throttle valve which can be swung up into chamber, S, by means of lever, J, which is pivoted at T. The carbureter is screwed on the inlet pipe of the motor at R. M is a flap valve which is held in a horizontal position by a spring which can be adjusted at N. The valve, M, does not close the pipe entirely; but when the motor speeds up, and the suction becomes more intense, it opens proportionally, thus making a greater inlet for the air, and so keeping the suction at D practically always the same. The result is that the quantity of gasoline which is drawn from this nozzle is the same at all speeds of the motor (provided, of course, that the throttle is wide open) and so a constant and perfect mixture is always obtained after the needle valve, E, and the spring, N, have been once properly set. The latest model of this carbureter has an elbow on top through which the air enters, instead of through A. Fitted in this elbow is a sort of piston valve with an adjustable spring which gives a wider range of adjustment than the arrangement shown. A test of this carbureter which we made recently on a single-cylinder gasoline car showed increased and almost constant torque at wide ranges of speed of the motor, which it was possible to throttle down so that it was just turning. The exhaust flame was of a light blue color, showing perfect combustion. An increase in power and

speed was also noticeable. The carbureter is a fair sample of the type termed "automatic," which is now used in place of the hand-regulated kind on all first-class automobiles. It is one of the most compact pieces of gas engine apparatus which we have seen, as the

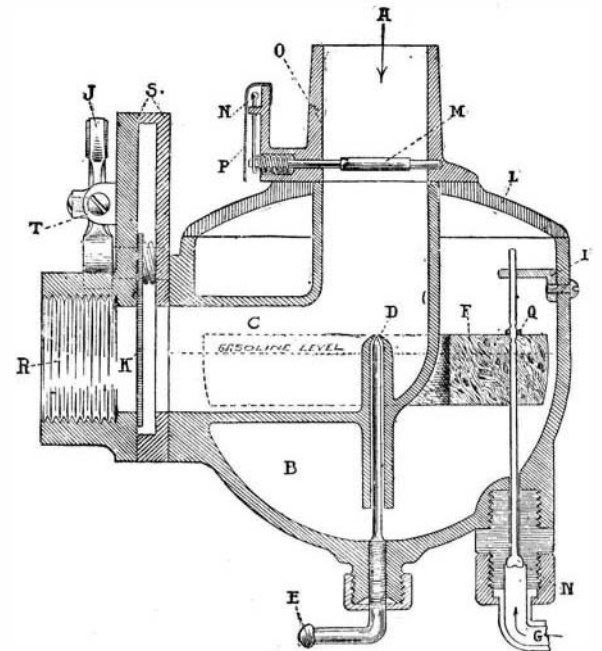

SCHEBLER AUTOMATIC CARBURETER FOR GASOLINE ENGINES.

float chamber and air pipe are combined in one, as shown. The general sales agent for the United States is Mr. F. H. Wheeler, Box 276, Indianapolis, Ind.

### AN ADJUSTABLE CANDLE HOLDER.

The difficulty with most candle holders is that they are not made adjustable to the many different sizes of candles which they may be required to hold. In the accompanying illustration we show an improved candle holder, in which the necessary adjustment can be very quickly and easily made. The holder comprises a headplate mounted to turn freely on the upper reduced portion of a spindle centrally secured in the main standard of the candle holder. The plate is retained in position on the spindle by a knurled nut. A pivot pin projects from the center of this nut, and several pins project from the plate adjacent to the nut. The main body of the spindle is threaded to receive an adjusting nut, to which are pivoted several curved retaining arms. The arms pass up through slots in the edge of the head-plate, in which they are movably held and guided by means of narrow metal strips secured across the ends of the openings. In use the retaining arms are first spread out by rotating the head-plate and adjusting nut about the spindle in the proper direction to feed the adjusting nut upward. The candle is then forced down onto the pins projecting from the retaining nut and the head-plate. Then, on rotating the plate

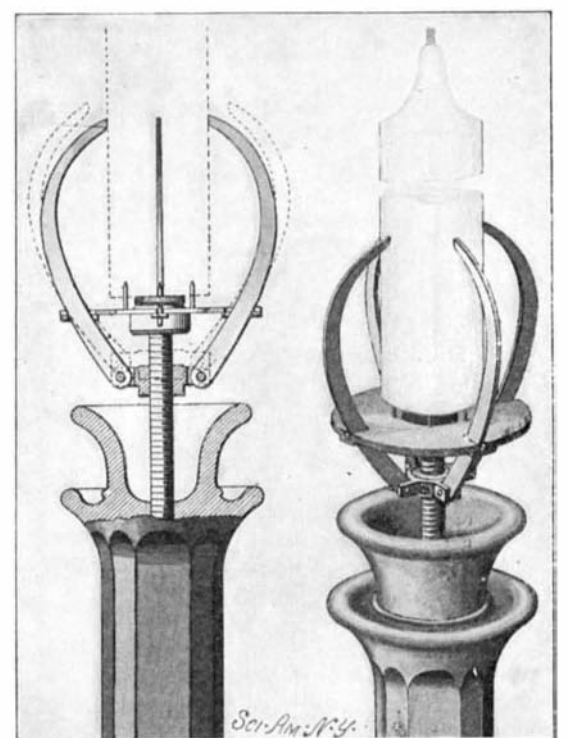

AN ADJUSTABLE CANDLE HOLDER.

in the reverse direction, the nut will be fed downward, causing the sharpened ends of the retaining arms to close against the candle and firmly grip it. The parts may be securely retained in any desired position by tightening a set-screw, which is threaded into the adjusting nut and bears against the spindle.

Mr. P. J. McGuire, of 389 East Santa Clara Street, San Jose, Cal., is the inventor of this improved candle holder.