

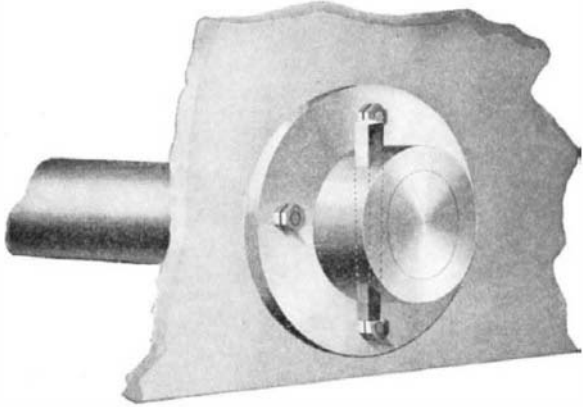

#### SHAFT FASTENING.

In very heavy machinery, such as stone crushers and the like, where the parts are subjected to excessive strain or jarring, it is important to provide a simple,



SHAFT FASTENING FOR HEAVY MACHINERY.

yet substantial means by which a shaft may be secured solidly and immovably in position within the frame of the machine. Mr. William A. Jones, of Branch, Pa., has invented a device of this character. It consists of a flanged sleeve which fits on to the shaft and is secured to the frame by bolts passing through the flange. The sleeve is formed with an inner hub, not shown in our illustration, which is conical and fits into a tapered opening in the frame of the machine, so that by tightening the bolts this hub will be wedged snugly and securely in place. The shaft is held to the bushing by a taper key which is driven into coincident slots formed in the bushing and shaft. The key should be located on the opposite side of the shaft from that on which the strain or pressure is to be exerted. This arrangement will be found advantageous because the shaft will not be weakened by the key slot on the side which bears the greatest pressure. In practice two of these fasteners will be employed on each shaft, one at each end, and as an added security against lateral displacement, the shaft may be turned to a smaller diameter at one end, thus forming a shoulder against which the conical hub at that end may abut.

#### ROCK DRILL ATTACHMENT.

In process of drilling rocks in quarries to form slabs or blocks, it is customary to produce holes in the shape of an ellipse, the holes being disposed in a row along the line of fracture, and the line coinciding with the long axes of the ellipses. We illustrate herewith an improved rock drill attachment, invented by Mr. David Awst Owen, of Granville, New York, which is designed to drill a hole with V-shaped grooves in its wall extending in the direction of the straight or angular line of fracture. The usual drill has the shank turned down to form a reduced portion, on which a cutter is mounted to turn. The cutter comprises a hub with wings extending lengthwise of the hub, either diametrically in alignment, or at angles one to the other, as clearly indicated in our illustration. In operation when the

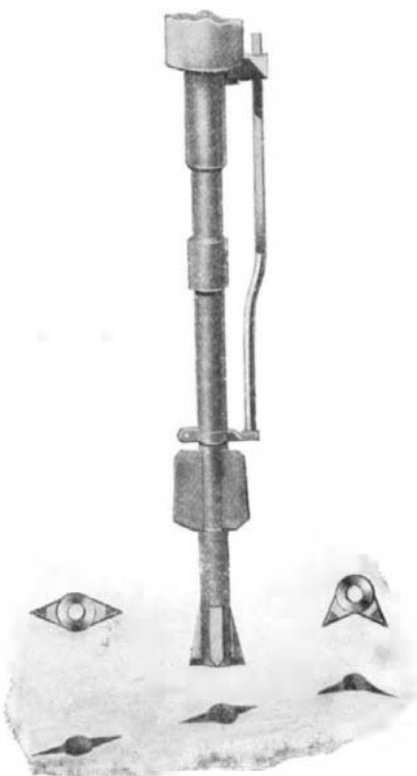

ROCK DRILL ATTACHMENT.

rock drill is set in motion to drill the holes in the usual manner, the cutter moves up and down with the drill, but does not turn with it. After the hole has reached a depth sufficient for the lower ends of the wings on the cutter to strike the rock, the V-shaped grooves will begin to be formed in the side walls of the drill hole. When a corner is reached in the line of cleavage, that cutter is used which has its wings extended at right angles one with the other. When the drill holes are completed and charged with explosives, and the latter ignited, then the rock will split along the line of cleavage much more evenly than with elliptical holes, particularly at the corners. When it is desired to sharpen the drill or the cutter, the several parts can be readily disconnected to allow sharpening. The device is very simple and durable in construction, not liable to easily get out of order, and can be readily applied to rock drills now used, it being only necessary to change the shank of the drill to accommodate the cutter.

#### A NOVEL FLY-CATCHER.

A new form of fly-catcher has been invented by Mr. Johann Zierl, care of Mr. W. J. Miller, Ballinger, Texas, which consists of a standard or post covered with a tacky substance which will attract the flies and hold them fast. This device is arranged to be suspended in any convenient place, and, as shown in our illustration, is made up of a metal tube, in the upper end of which a flared attachment is fitted, thus constituting a holder or reservoir for the tacky substance employed. To the lower end of the tube, a bowl is attached, which serves as a holder for the flies,

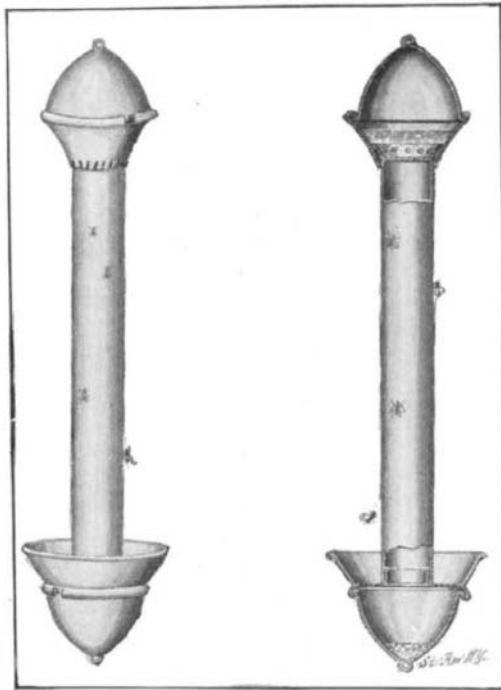

A NOVEL FLY-CATCHER.

and each end of the device is covered by a cap of conical form. The lower end of the flared reservoir is provided with openings, which register with perforations in the tube, and through these the tacky substance flows from the reservoir, down over the tube, smearing its entire surface. The adhesive substance is sweetened or otherwise made attractive to flies, which, when they alight on the tube, are held fast and slowly carried downward to the bowl by the flow of the sticky fluid. A sieve forms the bottom of the bowl and serves to retain the flies, while the fluid passes on into the cap below. When the reservoir is nearly emptied of the tacky fluid, the caps are interchanged, thus supplying a fresh quantity for the reservoir, and permitting the flow to continue without interruption. The caps are held in place by a form of bayonet joint, that is, each cap is provided with a lug adapted to engage the flanged edge of either the reservoir or bowl, both of which are provided with notches through which this engagement may be effected.

A fly-screen built on the principle of a roller shade has been invented and patented by Melchior Zuger Mayer, of East Rutherford, N. J. The screen is contained in a small casing which is secured to the window casing and which is hardly noticeable. A connection is provided, so that the screen will follow the movement of the sash. This connection can be easily broken, when the sash will work independently. With one of the screens on the upper and lower

portions of the window, the entrance of insects of any character will be effectually prevented.

#### IMPROVED RAILWAY CHAIR.

The greatest strain on a railway track comes at the joints, and it is rather an unfortunate circumstance that the parts which are subjected to the greatest strain must be weakened by bolt-holes necessary for securing the fish-plates. A recent invention, however, provides a very efficient means of securing rails to each other and to the roadbed at the joints, and at

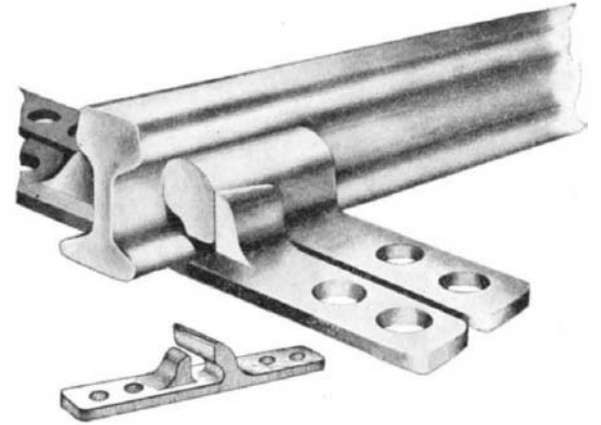

IMPROVED RAILWAY CHAIR.

other places as well, without the use of any bolts. Our engraving illustrates this invention, which is to be accredited to Rev. Francis W. Pool, of Havre, Mont. This improved railway chair comprises two identical members of the form shown in our detail view. Each member is formed of a metal plate with two upwardly projecting jaws thereon. The larger one of these jaws is provided with a lateral projection which is tapered along its outer face to lie parallel with the beveled or tapered inner face of the smaller jaw. In use the two members are placed under the rail, parallel to each other, but at right angles to the rail, so that the large jaw of one member will lie against one side of the rail, and the large jaw of the other member will lie against the other side of the rail. Now, on moving these members together, it will be observed that the taper face of the smaller jaw on each member engages the tapered projection of the larger jaw on the other member and serves as a wedge to tighten its grip on the rail flange and web. When the members have been tightly driven into engagement with each other, and the rail, they are held in place by spikes driven into the ties.

#### COMPENSATING DEVICE FOR ROPE TRAMWAYS.

By means of a very ingenious arrangement of compensating drums, Mr. William Y. Cruikshank, of Free-land, Pa., has produced an overhead traveling carriage for use on suspension cables stretched across rivers and the like, which will travel in horizontal position throughout its course, and which will furthermore act as a brake on the down grade, and as a power to assist the propulsion on the up grade of the cableway. The greater the load carried, the greater will be the down-grade friction and the up-grade power developed. As shown in our engraving, the carriage consists of a platform supported on a frame, in which the compensating drums are journaled, and from the latter, endless

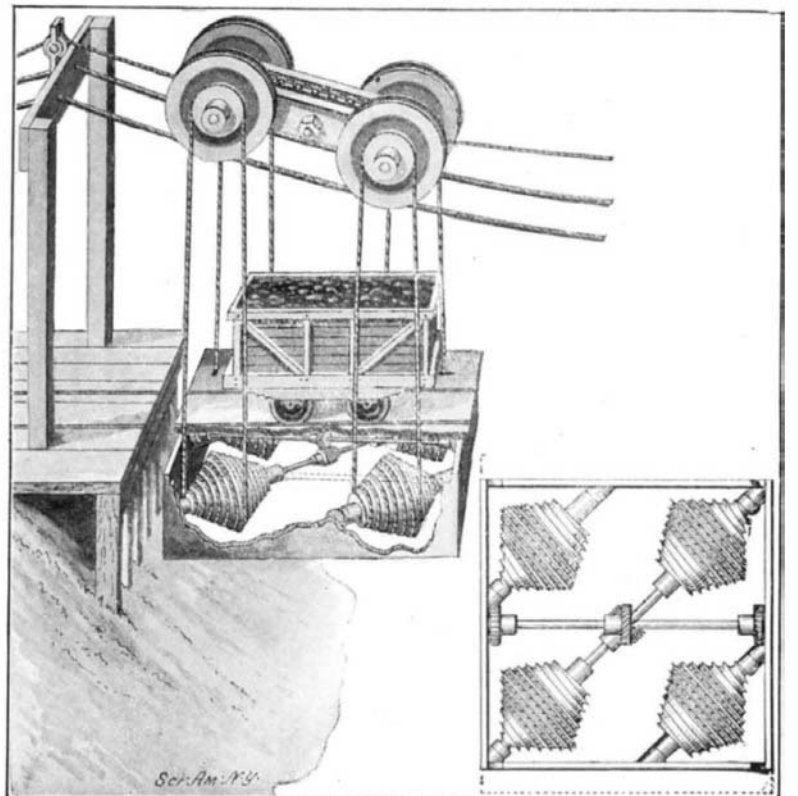

COMPENSATING DEVICE FOR ROPE TRAMWAYS.