

they can be successfully hardened is very small; but in no steel can the best results be attained in a variation to exceed 50 deg. Fahr., whereas in most steels the variation of one-fourth this amount would prove injurious.

Observations have shown that the steels which are capable of producing the best tools are those which can be hardened successfully only within narrow limits of temperature.

On account of the interest and importance of the correct measurement of temperatures, each new pyrometer that comes out is of interest to the public just in proportion to its possibilities in filling the requirements. The Morse Thermo-Gage Company, of Trumansburg, N. Y., have brought out a thermo-gage which will be of considerable interest. This thermo-gage is based on the comparison of color or degree of incandescence.

While these patents cover a multitude of forms in which the gage can be used, the form which is generally used is illustrated. In further explanation of the construction of the gage, we would add that inside the lamp tube illustrated is provided an incandescent lamp with a large filament in the form of a conical coil.

This filament is heated to the different degrees of incandescence corresponding to the different temperatures by an electric current taken from a storage battery. In the circuit of the lamp is included a delicate ammeter and a rheostat with finely-divided increments of resistance. With the aid of the rheostat the amount of current passing through the lamp can be regulated to any degree, and can be read on the scale of the ammeter. A table accompanies the instrument, which will enable the operator to know the temperature of the filament by the readings from the ammeter.

When this filament is superposed over the substance whose temperature is to be gaged, so that the substance can be viewed through the spirals, it will appear as a more or less bright spiral against said substance if it is at a higher temperature than the substance; on the other hand, if it is at a lower temperature, it will then appear as a more or less dark spiral against it; but when the substance and filament are at the same temperature, then the filament will apparently be obliterated from view, and appear to merge into that of the substance. This is because the rays then emitted by the substance whose temperature is to be gaged are identical with the rays emitted by the filament, and therefore the eye detects no difference. This merging effect is a well-defined phenomenon, and will enable the operator easily to read temperatures accurate within 5 deg. Fahr.

If it is desired to measure the temperature of any substance heated to incandescence, the substance is viewed through the lantern tube and the coils of the filament, and the incandescence of the filament is changed by the rheostat until it merges into the substance, when it will be at the same temperature as the substance, and the temperature can be read by the aid of the ammeter and the table accompanying the instrument. If, on the other hand, it is desired to heat a substance to a certain temperature, then the current is regulated by the rheostat until the ammeter indicates the desired temperature; then, as the substance is heated, it is observed through the tube, and the instant that its temperature is such that the filament of the lamp merges into it, it will be at the desired temperature.

#### AN ODD CASTING.

The accompanying photograph is a picture of a unique casting recently turned out by Daniel Galvin, a skilled artisan and molder of this city. Mr. Galvin calls the design "The Old Kentucky Home," and its chief claim to distinction lies in the fact that it was made at one casting.

A few years ago Mr. Galvin created something of a sensation among molders all over the country by turning out complete, at one cast, a metal representation of the "Old Oaken Bucket." His latest achievement, on which he worked for some months, at leisure moments, far surpasses his first effort in this line.

"The Old Kentucky Home" is of brass. It represents a cottage with a colonial front, surrounded by a yard and a panel fence. Every detail of this truly admirable piece of mechanism is complete and correct. It seems almost impossible, even to a man experienced in the secrets of Mr. Galvin's craft, that it could have been produced, intact and entire, at a single casting. No molder who has examined it has been able to solve the riddle of Mr. Galvin's discovery in the line of castings.

The base of the design measures  $8\frac{1}{2}$  inches by  $6\frac{1}{2}$ . The fence is eight inches by six, and one inch in height. The posts, panels, etc., are worked out with as much care as if the model were of large size. The house proper is  $3\frac{3}{4}$  inches long,  $3\frac{1}{2}$  inches wide, and

$3\frac{1}{4}$  inches in height. There are three sets of steps, three doors, six windows, three rooms, three chimneys, and a dormer opening in the attic. The house is not solid, having an interior as perfect and symmetrical as the exterior. Even the air spaces in the garret above are worked out with a fidelity that is wonderful.

Mr. Galvin is a well-to-do citizen and popular artisan. He is connected with a large local foundry and repair shop in a responsible capacity.

#### How Edison Perfected His Storage Battery.

The writer of this lives near Edison's laboratory and is in a position to know something of what is going on there. We believe that very few inventions have been so thoroughly worked out and perfected before being offered to the public as this one. Not only once but repeatedly, within the long term during which

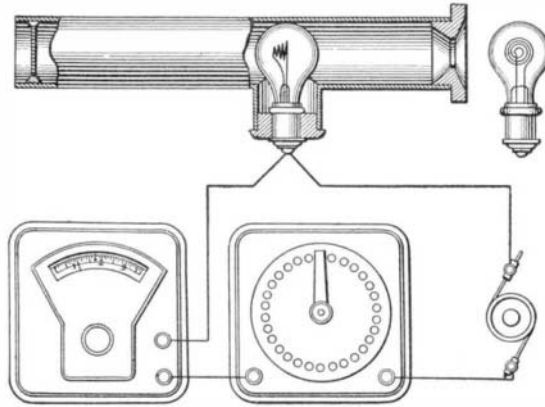

DIAGRAM OF THE THERMO-GAGE.

Edison has been working on this battery, his associates in the laboratory have been quite satisfied with it—have believed it to be practically perfect and have urged him to begin its manufacture for the market. But he has until now persistently declined—invented some new and apparently needlessly severe test for the battery; and in every case where any weakness whatever has developed even under extreme tests, not likely to be met with in practice, has gone to work again with inexhaustible patience and persistence to overcome such point of weakness.

Edison set out to remedy all these defects (of the lead cell). His battery is considerably lighter for a given power—uses no lead; power can be taken from it rapidly without injury—it has been short-circuited—and immediately afterward found in good working condition; it can be charged much faster—power for a forty-mile run for an ordinary car can be put into it in an hour without injury; it can stand idle indefinitely without deteriorating; it uses no acid.

These results have been attained by what we know to have been a very exceptional and thorough process of step-by-step invention in which expenditure of time and of money have been literally disregarded—disregarded to an extent not possible with most inventors.

These batteries have been put into all sorts of standard electric vehicles and run—by men knowing absolutely nothing about them and only how to work the levers—over all sorts of roads, up hill and down, in all sorts of weather. A battery has been rigged up on a jack out in the yard of the laboratory so that whenever the power was running—about ten hours a day—

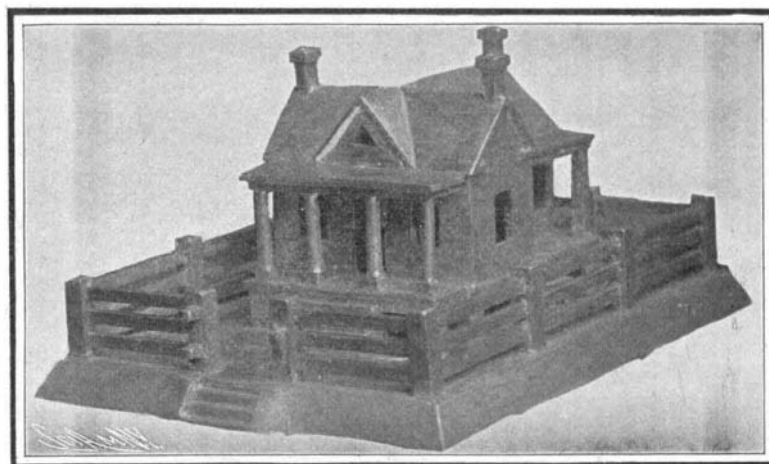

AN ODD CASTING.

it was continuously raised up and let fall upon some logs; this was kept up for months to study the effects of far more severe jolting than can be given to it in service. A battery, after having its more delicate electrical connections taken off, was thrown out of a third-story window of the laboratory and then with nothing else done to it except put on the electrical connections, it was tested and found to be efficient. The men driving the experimental vehicles or, rather, the standard vehicles equipped with experimental batteries, were repeatedly given directions to start out and take every right-hand turn for seven turns regardless of the road or where it led to, and then home

again. These men drove the vehicles every day for many months and purposely gave them the most severe possible tests. In short, we know whereof we affirm when we say that it will scarcely be possible for any user to give one of these batteries as severe a test as they have received.—American Machinist.

#### Conditions Governing Entries in United States for the Gordon Bennett Cup Race.

The Automobile Club of America is open to receive entries for the cup race, upon the following conditions:

1. Each entrant shall deposit with this club the sum of six hundred dollars.
2. The racing committee of this club shall decide which of the entrants may compete in the cup race. This decision may be arrived at by a contest, or by the committee without a contest.
3. Any entrant who is not nominated by the racing committee for the cup race shall have his entrance fee returned to him.
4. Any entrant who, after being nominated for the cup race by the committee, does not start, shall forfeit his entrance fee of six hundred dollars.
5. If three entrants are nominated to take part in the cup race, each entrant shall have two-thirds of his entrance fee (after deducting his proportion of the expenses incurred in holding the race) returned to him, provided he starts in the race.
6. If two entrants are nominated, each of such entrants shall have one-half of his entrance fee (after deducting his proportion of the expenses incurred in holding the race) returned to him, provided he starts in the race.
7. These rules are supplemental to the rules of the Gordon Bennett cup race, by which each entrant agrees to abide.

#### Accidents to the Lebaudy and Langley Flying Machines.

Accidents which have lately occurred to the Lebaudy airship and the Langley aerodrome (described respectively in our issues of December 5 and October 17) have shown the weak points in both the "lighter than air" and the "heavier than air" types of flying machine. The Lebaudy airship came to grief on November 21, by being driven against some trees when making a landing, while the Langley aerodrome was again launched over the Potomac River on December 8, with the result that it darted upward, described a circle, and plunged into the river, striking bottom and being afterward pulled with difficulty out of the mud, whence it came in a demolished condition. Mr. Manly, the operator, fortunately escaped with a wetting. The accident was laid to the failure of the launching apparatus to work properly; but as the reports state that the machine shot straight forward some yards before darting upward and turning a somersault, it would seem as if the launching apparatus was not so much at fault as that the operator was unable to control the aeroplanes, or, at any rate, to control them quickly enough to avoid disaster. This accident has put an end to Prof. Langley's experiments for the year, and it has again demonstrated that a flying machine constructed on the aeroplane, or "heavier than air," system, is an exceedingly difficult thing to control. The Lebaudy disaster, which will be found illustrated in the current SUPPLEMENT, has shown the weaknesses of the airship type of flying machine, should a moderate puff of wind occur at an inopportune moment, when a landing is being made.

#### The Largest Public School.

A new school is to be erected in Hester Street, between Essex and Norfolk Streets, and facing Seward Park, New York, which will be the largest in the world. It will occupy 200 feet on Essex Street, the same on Hester Street and 75 feet on Norfolk Street. The height, six stories, exceeds that of any present school. There are to be a basement and sub-cellar, and in the basement will be an auditorium capable of seating 1,600. The school will be able to accommodate about 4,500 pupils. Altogether there will be 124 classrooms.

The building will be practically two schools, one for boys and the other for girls. The entrance for the girls will be in Norfolk Street and that for the boys in Essex Street.

On the sixth floor will be a gymnasium, cooking room, workshop, two baths, lockers and seven classrooms. The exterior of the building is to be of buff and blue Indiana limestone and the interior will be finished in oak. It will be the first school in this city to have elevators to carry the children to the upper stories.

Each fruit grower of New York will be furnished with a padded barrel by the State Commission to the World's Fair. The barrel will be packed by the grower and shipped to the Fair at State expense.