

THE COMBINED THIRD AND TRACTION RAIL SYSTEM OF HAULAGE.

The accompanying illustration shows a plant of the Morgan system in operation at the works of the Donohoe Coke Company, of Greensburg, Pa. Many plants of this system are now in successful operation in various parts of the United States, demonstrating its adaptability to the various conditions of mine haulage. At the Donohoe works referred to, the locomotive is hauling out of a drift opening, and a considerable portion of the track is outside of the mine. It is getting out a large output on a 4 per cent grade against the loads. At the Sarah mine of the Pittsburg Coal Company, at Douglass Station, Pa., the locomotive is hauling the loads up a 10 per cent grade. The third rail carries 550 volts pressure; 200 feet of this third rail is outside of the mine and no delay was experienced from the heavy snow and sleet storms of last winter and spring.

At the Murphysboro mine of the Big Muddy Coal & Iron Company, of St. Louis, the locomotives are hauling heavy trips of cars on grades both against and in favor of the loads, thus demonstrating the capability of the locomotive to safely bring loads down heavy grades as well as its power to haul up such grades. The capability of the system to work successfully on very sharp curves and on light rails is well illustrated at the Minglewood mine of the Massillon Coal Mining Company of Massillon, Ohio, there being many sharp curves in the 7,000 feet of motor road and the rails weighing but 16 pounds per yard.

In this system the electric current to supply the motor and the traction to drive the locomotive along the track are furnished by a single third rail. The third rail consists of heavy iron bars, perforated at regular intervals throughout their entire length, and made into a continuous rail by means of fish-plates

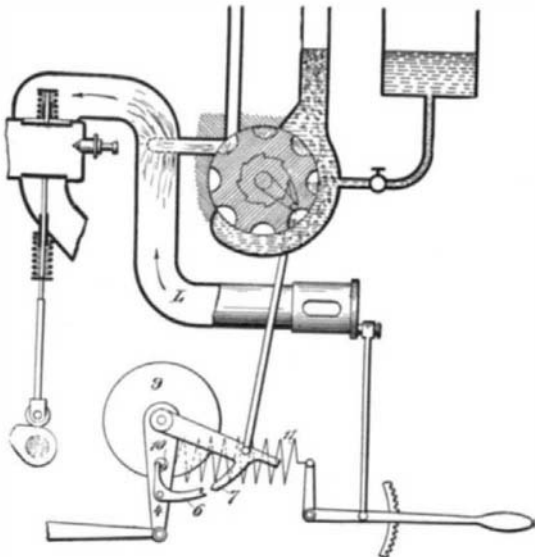
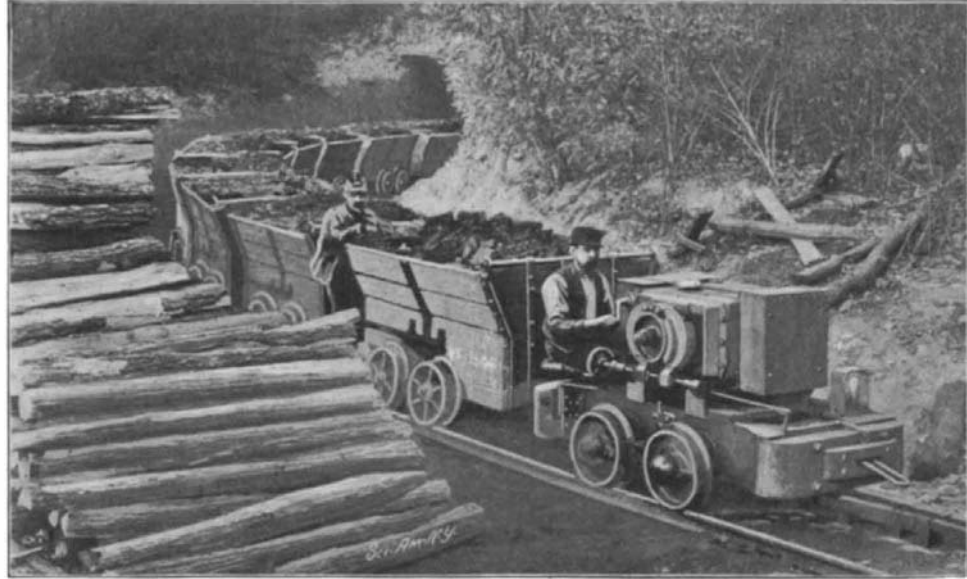

DIAGRAM OF GOBRON-BRILLIE CARBURETER.

much after the manner of regular track rails. This continuous rail is inclosed in a specially prepared wood casing, which serves the double purpose of insulating the rail and protecting men and animals from the current. This complete third rail is laid 5 inches off the center of the regular track, thus giving room for the animals to work, so there need be no interruption to the working of the mine while the plant is being installed.

The locomotive consists of a substantial steel frame mounted on suitable track wheels. Into this steel frame are mounted two steel sprocket or traction wheels, which are driven by an electric motor contained in the body of the locomotive by means of suitable gearing. The sprocket or traction wheels, which engage the third rail, serve the double purpose of driving the locomotive along the track and taking up the electric current from the third rail to feed the electric motor, the track rails being used as the return conductor. The locomotives of this system now in operation are of 30, 60 and 120 horse power. The company is prepared to build locomotives of this type up to 240 horse power or larger if desired.



COMBINED THIRD AND TRACTION RAIL SYSTEM OF HAULAGE.

ALCOMOL AUTOMOBILES AT THE PARIS ALCOHOL EXHIBITION.

I. THE GOBRON-BRILLIÉ.

BY OUR PARIS CORRESPONDENT.

The Paris Alcohol Exposition, held under the auspices of the Minister of Agriculture, has proved a great success. The Grand Palais presented the unique

sight of a great variety of apparatus, all of which used alcohol to accomplish widely varying results. At one end was a large collection of fixed motors, many of them at work, and at the other were the automobiles, either in the stands or going through their evolutions around the race-track in the center. Then came the lighting and heating appliances. The show was preceded by a series of official tests, which took account of the consumption of alcohol and general performance, and afforded valuable data on the subject. The progress of the alcohol motor is surprising when it is considered that the industrial application of alcohol dates only a few years back. In 1894-5 it came into use for lighting in Germany. At the first Criterium of alcohol automobiles held at Paris in 1899 only 4 vehicles were entered, and but one covered the distance Paris-Chantilly. The Paris Exposition showed scarcely anything but a Koerting fixed motor and a De Dietrich automobile. Last year's Criterium, however, brought out no less than 40 automobiles, and most of them made Paris-Rouen without difficulty. Then came the automobile show of last winter, at which several machines were on exhibition. The present show has a great number of alcohol automobiles, built by the leading Paris firms. Most of these machines use a mixture of alcohol and gasoline in equal parts.

Among the most characteristic and original systems is that of the Gobron-Brillie Company. M. Brillie is recognized as one of the pioneers in alcohol work and was one of the few to be represented in the preceding show. The carbureter is designed on the atomizer principle, and so disposed that a definite quantity of liquid (alcohol and gasoline in equal parts) is atomized at a time in the presence of a determined volume of air. The carbureted gas drawn into the cylinder thus remains constant in quality under varying conditions of speed, etc. The arrangement of the carbureter is shown in the diagram. The main distributing wheel carries on its periphery a series of pockets of a determined capacity. As the wheel revolves these become filled with the liquid

and are successively brought before the orifice on the left, which communicates with the atomizer nozzle and with an air-pipe above. The atomizing action is brought about by the suction in the large pipe, *L*, below, and the liquid is vaporized and mixed with the air in a definite proportion. It is found that for a constant volume of air (corresponding to a cylinderful) a constant volume of carbureting liquid is needed. A proportion of 1.05 to 1.10 in 10,000 by volume answers equally well for gasolines of different specific gravity and also for the 50 per cent mixture of alcohol and gasoline usually employed in the alcohol motors. In the case of pure alcohol this proportion gives a slightly less power. The distributing wheel is made to advance by a ratchet whose teeth equal the number of pockets. The ratchet is pushed by a pawl which is operated from an eccentric on the motor shaft through the intermediary of the regulator, *R*. This latter device is ingenious and simple, and serves to give different speeds to the motor. The eccentric gives the lever a back-and-forward movement to the right and left, and this oscillation is transmitted to a weight, 9, held in place by the spring, 11. The weight carries a pin, 10, which is held by the spring

against the right-hand side of an opening in the lever. The weight is loose on the shaft, upon which it is given a slight reciprocating movement. The lever has a trip, 6, whose vertical arm rests against the pin, while the horizontal arm may strike against the point, 7, of the upper lever, which carries the driving rod for the ratchet. If the speed of the motor tends to exceed that which is regulated in advance by the tension of the spring, 11, the weight, owing to its momentum, is displaced to the left and the pin pushes the vertical arm of the trip. The lower arm, 6, is thus lifted and escapes the point, 7, of the lever, and this throws the ratchet out of action until the motor comes back to speed. The spring is regulated by a hand lever which gives speed variations between 300 and 1,400 revolutions per minute.

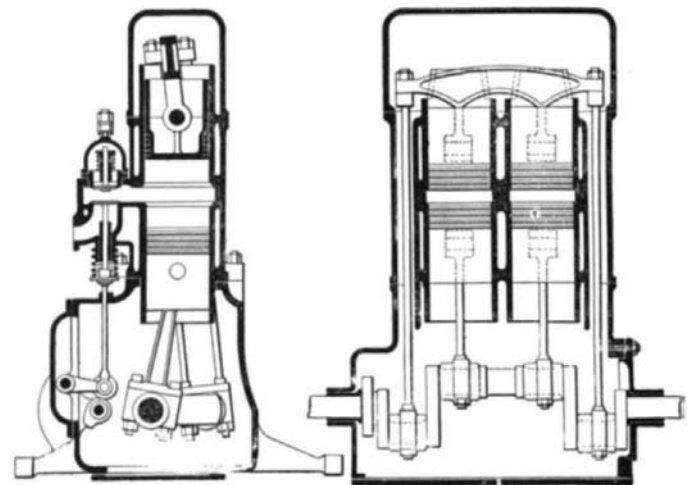

SECTIONS THROUGH GOBRON-BRILLIÉ MOTOR.

It will be remembered that the aspiration is produced in the pipe, *L*, and to carry this out properly it is necessary to regulate the admission of air at the extremity of the tube to correspond to different speeds. For this the tube has a cap with openings which is operated by the same lever. This is not to modify the carburetion, but simply to change the air-draught for the atomizer. To provide for the escape of air the carbureter must either be open at the top or connected above with the main reservoir. The motor, shown in section, has two cylinders and two pairs of pistons, the explosion taking place between the two pistons.

We expect to show some of the other forms of the French alcohol vehicles and carbureters in a later issue.

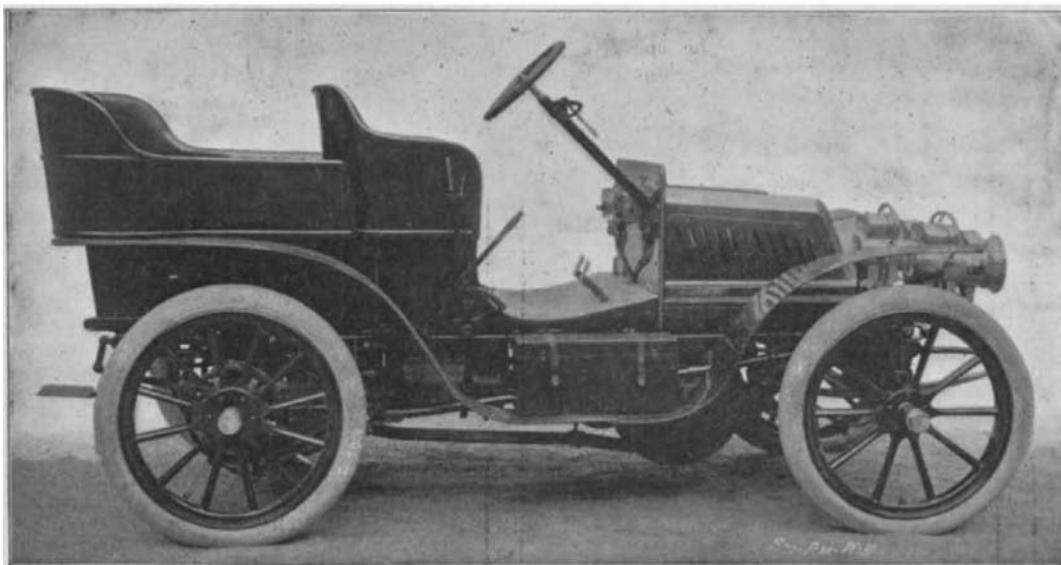

THE GOBRON-BRILLIÉ 12-HORSE POWER ALCOHOL TONNEAU.

The new plant of the Gruson Iron Works at Eddystone, Pa., was put into operation on October 21. The works will produce the Gruson coast defense turrets which are at present made at the Krupp works in Germany, although the manufacture of all kinds of heavy castings will be engaged in.