

through the target and exploding on the other side, but the shrapnel is totally different. In the war head of this dangerous projectile are several rings of blind holes, reminding one of woodpecker's holes in a dead tree. Each one of these holes means $\frac{1}{4}$ second on the fuse that runs around the inside, and just before inserting in the gun, a tool resembling an awl is driven through one of these holes, puncturing the fuse at the desired point. It is aimed to explode the shell a short distance before reaching the mark, the explosion throwing the numerous bullets and fragments over a large area, spreading out in shape similar to a cone. The

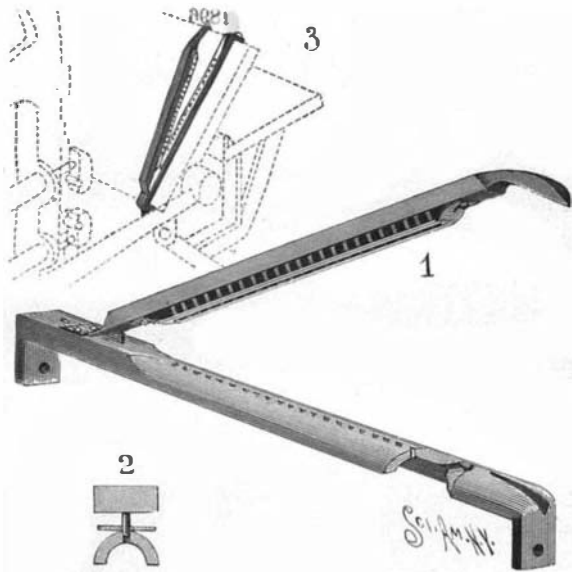

PERFORATOR FOR PRINTING PRESSES.

time from the gun to the mark on this range was 7 seconds, and, when one's nerves are on a tension, waiting for the shell to explode, 7 seconds seems a very long period. As before stated, the winner on this range was the Second Battery, making 197 points, the Sixth gaining 185, and the First 41. The First Battery fired on June 15, the Second Battery on June 19, and the Sixth Battery on June 20. If the Second wins the "Trophy" next year it will close the contest, as they will then have been a winner three times.

We are indebted to Mr. G. E. Stonebridge, the author of the article, for the accompanying photographs.

THE HONE AUTOMATIC FLOOD-GATE.

When it is considered how many disasters are caused by the sudden overflowing of reservoirs and dams, it is not astonishing that inventors should have endeavored to devise some mechanical means which would automatically allow the surplus water to escape as soon as the level would rise above a certain height. The most recent contrivance of this nature is the invention of Mr. Henry Hone, of Chicago, Ill., who conceived his idea while in charge of one of the mountain-lakes of Colorado. Mr. Hone's apparatus presents many novel features of construction, among which may be mentioned the means provided for discharging the water near the bottom, without draining the dam.

In the dam-wall a casing is set, which is permanently closed at about its middle portion, leaving an open port below and a space above, which is normally closed by a door hinged to the partition. Secured to the hinged door are chains passing over idlers and secured to a valve sliding vertically in guides so as to close or open the port below the fixed partition. Together with the partition and the hinged door, the valve completely closes the breach of the dam in which the casing is set.

The hinged door is arranged above the normal level of the dam and is, therefore, closed ordinarily. When, however, the water rises above a certain height, the pressure forces the door down, causing the valve to be raised and the lower port to be opened, and allowing the surplus water rapidly to escape. As the level of the water falls, the door swings back, thus causing the valve to close the port. To prevent the door from being thrown so far forward that a return is impossible, a stop is provided which limits the upward movement of the valve.

It may happen that driftwood or other obstructions may not permit a return of the door, thus preventing the valve from closing the port, and allowing the dam to drain. The inventor, therefore, employs a box having an open top, but standing around the port so that all

water must pass over the box. Evidently the dam can never drain below the top wall of the box. Back pressure of the water is also prevented from hindering the gate in its action. In the rear of the tank a door is provided which can be easily drawn up to permit complete drainage whenever desired. To increase the stability of the gate as an integral part of the dam, a broad flange extends from the sides of the gate into the dam, and from the bottom of the gate into the foundation upon which the gate rests, to prevent any leakage. More extended information can be obtained from Mr. W. I. Reedy, of 91 Illinois Street, Chicago, Ill.

A PERFORATOR FOR PRINTING PRESSES.

In printing bank-checks and similar stationery the operations of printing and perforating have hitherto been performed separately, thereby consuming no little time and requiring considerable labor. A perforator has been invented by Mr. Gustavus A. Evans, of Nelson, British Columbia, by means of which the checks can be printed and perforated at one operation. Fig. 1 shows the device in perspective and Fig. 2 in cross-section. Fig. 3 is a reduced view of the perforator as applied to a press.

The device consists of two parts, a bed-piece and a punch-bar. The bed-piece is provided at its ends with lugs which are screwed to the top and bottom edges of the platen in the manner shown in Fig. 3. A series of holes in the top of the bed-piece open at their inner ends into a channel formed on the under side of the bed-piece (Fig. 2), which channel serves to receive the disks cut out of the paper, openings being provided which lead from the ends of the channel to the face of the bed-piece so that the disks can be discharged.

At its ends the punch-bar is provided with springs, the lower of which is screwed to the bed-piece, and the upper of which is formed with a V-shaped guide which is designed to engage a correspondingly-shaped recess in the bed-piece to insure correct perforations (Fig. 1). The lower spring normally holds the punch-bar in open position. On the under side of the punch-bar are punches designed to register with the apertures in the bed-piece when the impression is made. To release the paper a slotted bar, spring-secured at its ends and longitudinally movable, is mounted beneath the punch-bar.

When the punch-bar moves into a closed position, then the paper-releaser moves in contact with the bed-piece, and is flattened out. As the paper extends over the face of the bed-piece, the releaser engages the paper at the closing of the plates and securely holds the paper in place during the perforation. When the platen opens, the punch-bar is also opened by the lower spring

previously mentioned, thus withdrawing the punches from the paper. The releaser then returns to its normal position, and in so doing cleans the punches.

The perforating device can be readily attached to the end of the platen, so that the face of the tympan can be brought almost level with the top face of the bed-piece, rendering it possible to print close to the perforations, if need be, without tearing the paper.

AN IMPROVED PACKING.

We present herewith an illustration of a novel packing invented by Wilbert Black, of 3917 Annunciation

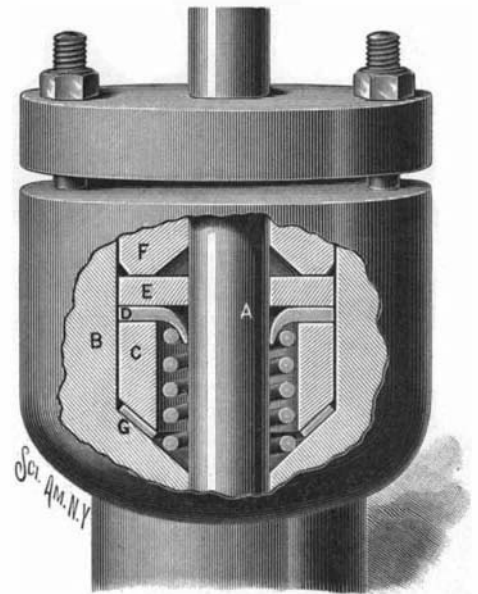

A NEW PACKING.

Street, New Orleans, La., which packing can be readily applied to the stuffing-boxes of hydraulic and other plunger pumps in order to prevent the passage of fluid in both directions.

The packing is here shown applied to a pump, the barrel of which has a box, B, to which a gland, F, is fitted. In the barrel a plunger, A, reciprocates. The box, B, contains a snugly-fitting thimble, C, which receives the plunger as well as an expansive spiral spring bearing on the bottom of the box, B. A leather washer, G, is interposed between the lower end of the thimble and the bottom of the box. The upper end of the thimble forms a seat for a leather packing-crimp, D, turned down and engaged by the upper end of the coiled spring. Upon the crimp, D, a ring, E, is set, which ring is held down by the gland, F, between the thimble, C, and ring, E; and the inner portion of the crimp is left free to accommodate itself to the movements of the plunger. On the compressing stroke of the plunger, the crimp, D, is forced outward against the plunger principally by the pressure developed within the barrel. On the return stroke of the plunger, the crimp, D, is forced by the spring against the plunger to prevent the entrance of air into the barrel during the outward movement of the piston, the air being partially exhausted within the barrel during the outward stroke.

The Protection of Dynamite Magazines.

Trials have been made in France relative to the best method of building dynamite magazines. One was constructed to hold 1,100 pounds of dynamite. A gallery of communication 55 inches in height and width was bent twice like a hand brace and at the outlet ended in the safety automatic plugging device. This consisted, says The Engineering and Mining Journal, of a prolongation of the gallery through a mass of cement poured into an excavation made around it. In front of this channel the plug, which is of cylindrical shape, 48 inches in height and width, is placed. Two-thirds of its length is made of cardboard, or rather, leather board, and the remainder of wood. The contents were fired by electricity; a dull report was heard and after a few minutes smoke was observed to be issuing from the orifice, and the experiment was declared to be successful.

A SUCCESSFUL operation has just been performed in St. Luke's Hospital, New York City. A tumor was removed from the inside of the sheath of the spinal cord. It was necessary to cut into six vertebrae, and the patient was kept under anesthetics for more than three hours. He was operated upon after a number of German specialists had pronounced that his ailment was rheumatism.

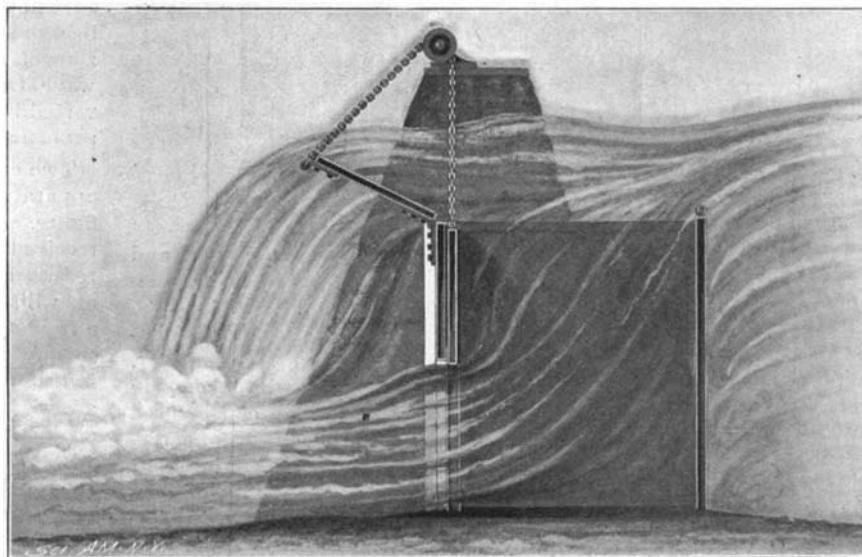

GATE OPEN, SHOWING FLOW OF WATER.

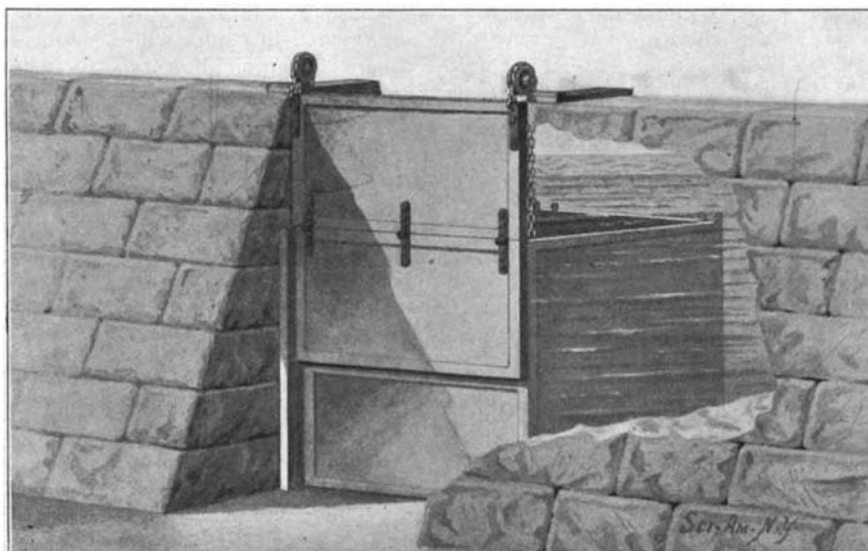

GATE CLOSED, SHOWING RETAINING BOX.