

### A NOVEL GROOVING-SAW AND DADO-HEAD.

In a very ingenious invention which has been patented by James M. Garrison, of Santa Barbara, Cal., a simple mechanical device has been provided for quickly setting a grooving-saw in any angular position relatively to the arbor, to cut wide or narrow grooves. Fig. 1 is a perspective view of the invention. Fig. 2 is a sectional plan view. Fig. 3 is a plan view with the saw-blade set at an angle.

The body of the dado-head carries lugs which engage one face of the saw-blade. The other face of the blade

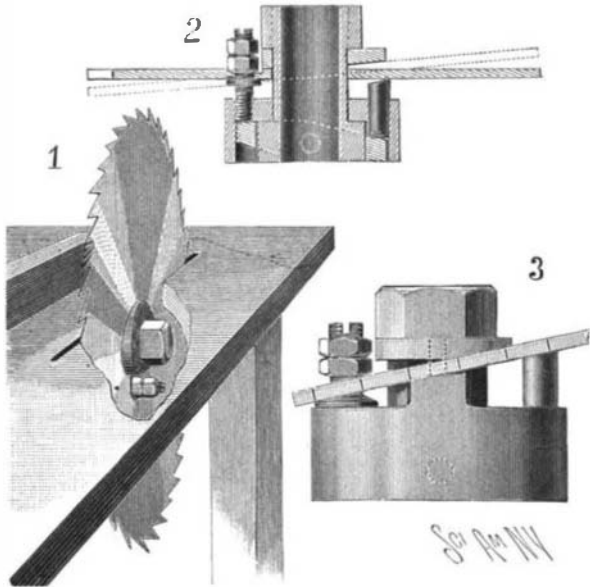

AN INGENIOUS ARRANGEMENT FOR ADJUSTING WATTLE-SAWS.

is engaged by a washer beveled at one side to fit the blade when tilted. Adjusting devices hold the saw-blade at any angle relatively to the saw-arbor. These adjusting devices comprise an adjusting-screw received in the head and a pin sliding in the head. A ring-shaped lever is fulcrumed in the head and is engaged at opposite sides by the screw and pin. The adjusting screws, as shown in Figs. 2 and 3, has a collar on one side of the blade and two nuts on the other.

In tilting the blade from one position to another the adjusting-screw is turned by means of a screw-driver, thereby raising or depressing the oppositely-located slidable-pin, so that the blade is set at the desired angle. The mere turning of the screw causes a proper tilting of the saw. The ease and rapidity of this adjustment are meritorious features not found in similar devices which have been hitherto employed. The arrangement is adaptable to saw-arbors, shaper-arbors, or to any arbor on which a dado-head can be fitted. The only tool employed in adjusting the blade is a screw-driver.

### Improvement in Celestial Photography.

Where anything like systematic astro-photography is contemplated, it is customary to rely upon one of two expedients. Sometimes a telescope is built exclusively for this line of work. The objective is corrected so that the actinic violet rays concentrate at just the right point. But such an instrument is worthless for visual work, and it is employed only for photography. This is the case, for instance, with the fine 24-inch glass given to Harvard by the late Miss Caroline W. Bruce. The other resource is to provide an additional correcting lens that can be swung into position in front of the object glass. This is the plan adopted at the Lick and Greenwich observatories. It works admirably, but it has drawbacks. The corrector is heavy and costly. It absorbs a good deal of light and reduces the photographic power of the instrument accordingly; and the focus is shortened, so that the plateholder must be thrust up inside this tube a little distance from the eye end. A new way of meeting this difficulty is reported from the Yerkes Observatory, which, though conducted under the auspices of the University of Chicago, is situated at Williams Bay, Wis. In the September number of *The Astro-Physical Journal*, Prof. George E. Hale, the director, recounts some recent experiments by G. W. Ritchey, of his staff. The great 40-inch telescope at this observatory was designed for visual work and has no correcting lens. But such an attachment is now found

to be unnecessary. If a thin yellow screen is placed in the focal plane of the instrument and a photographic plate in immediate contact therewith, the most gratifying results are secured. The pictures show a sharp definition never before exhibited in work done with visual telescopes. Special screens have been made under Mr. Ritchey's supervision. They are of plate glass, coated with collodion, and having a delicate, greenish yellow tint. Prof. Hale says that Mr. Ritchey suggested this expedient eight years ago, and tried it on the moon—a very bright object—in 1897. But so far as is known, no attempt to photograph faint objects like nebulae and star clusters has been made until now. A fine picture of the famous globular cluster in the constellation of Hercules, containing several thousand stars—at least 3,200 have been counted on the plate—has been secured by Mr. Ritchey after an exposure of ninety minutes. A comparison of this photograph with those obtained with special photographic telescopes demonstrates the success of the method. The achievement opens the way to several other lines of photographic research, notably parallax work, in addition to "spectro-heliography," which is Prof. Hale's specialty. And the example thus set by the Yerkes Observatory will doubtless be followed elsewhere.—*New York Tribune*.

### THE LANGEN MONO-RAIL ROAD AT THE PARIS EXPOSITION.

In our issue of May 5, 1900, we published an exhaustive illustrated description of the Langen suspended railway, which, as an engineering novelty, has attracted no little attention here as well as abroad. The *Continental Gesellschaft fuer Elektrische Unternehmungen*, the builders of the suspended railway extending from Barmen to Elberfeld in the Wupper Valley, Germany, have installed at the Vincennes Annex of the Paris Exposition a short road operated on the Langen system. The Vincennes road is about 200 feet in length and is composed of two bridges, each of 100 feet, resting upon three central posts. The cars run on each side of the posts on two double-wheeled motor-trucks attached to the car roof. Current is fed by a slip shoe and a contact-rail.

The general appearance of the cars is shown in our illustrations. Each car has a capacity of fifty and is divided into first-class, second-class, and smoking compartments. The motors are of 36 horse power, and the speed (on the Barmen-Elberfeld road) about 25

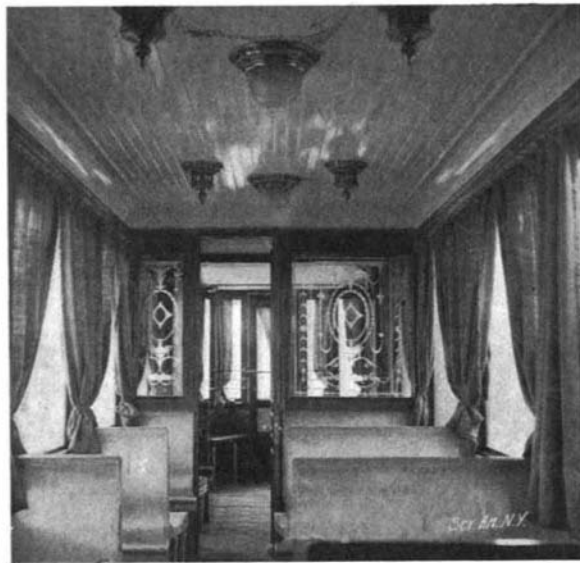

INTERIOR OF CAR.

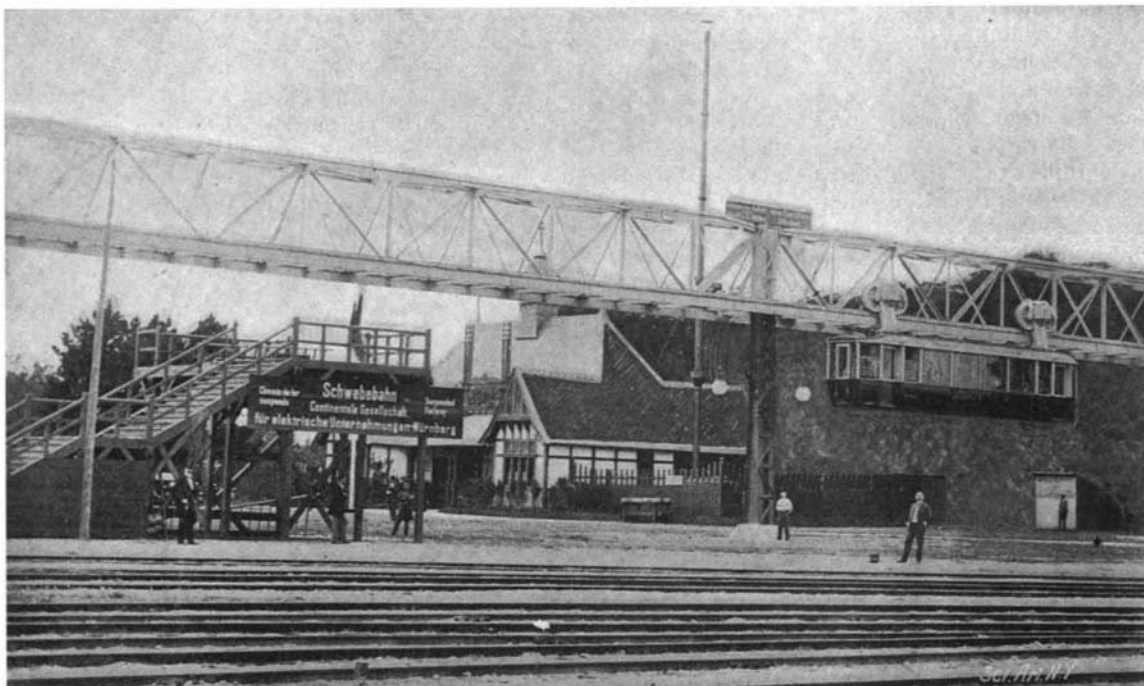

LANGEN SUSPENDED RAILWAY EXHIBITED AT VINCENNES.

miles an hour. Westinghouse air-brakes, as well as electrical and hand brakes, are provided.

The Vincennes road, although in working order, has not been continuously operated, since its short length hardly enabled the exhibitors fully to demonstrate the merits of the system.

### A COTTON PER CENT SCALE.

A scale of simple construction to be used for determining the percentage of lint contained in seed-cotton forms the subject of an invention for which a patent has been taken out by George R. Brown, Pledger, Tex. The scale comprises a balance-beam mounted on a

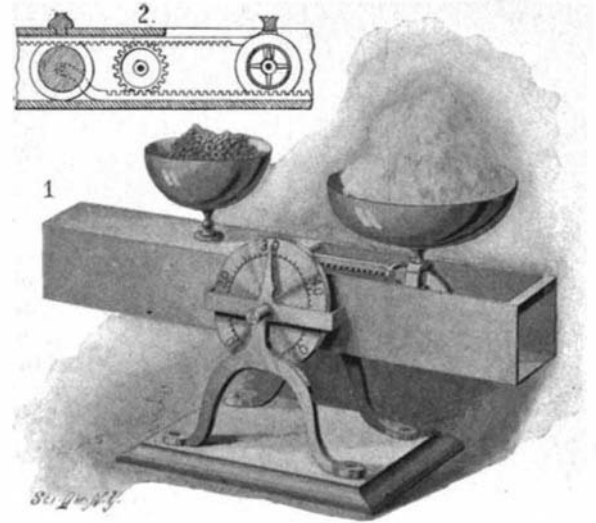

A COTTON PER CENT SCALE.

rock-shaft and provided with two trays—the one fixed, the other movable. The movable tray is supported by arms in which a flanged roller is journaled. Extending from the arms lengthwise of the beam is a rack which passes over a second flanged roller serving as a counterpoise. From the spindles of the second roller another rack extends along the bottom of the beam and underneath the first roller. The two racks mesh with a pinion carried by the rock-shaft. A hand-wheel is also mounted on the shaft, and on the surface of the hand-wheel numbers are inscribed with which a pointer coacts to indicate the percentage of the material in the trays. By rotating the hand-wheel the counterpoise roller and the movable tray are caused to move toward or from each other. As the proportion of lint to seed-cotton varies from 25 to 40 per cent, the scale is graduated only from 25 to 50 per cent.

A handful of cotton is taken from the lot offered for sale and cleaned with a small hand-gin. The seeds, with the hulls and dirt, are placed in the fixed tray; and the lint is deposited in the movable tray. The hand-wheel is then turned until the beam is balanced. By referring to the scale, the percentage of lint contained in the cotton is immediately ascertained.

### Islands of Chincha.

In the South Sea, opposite the Bay of Pitco, and nearly midway between the equator and the tropic of Capricorn, are found the Chincha Islands. These are, in reality, only a series of bare, rocky peaks, which rise out of the ocean. Although their surface is but small, it is no less true that not long ago this was one of the richest territories in the world on account of the extensive guano beds which were to be found here. These had been formed by the innumerable sea-birds which inhabited the rocks. To judge of their number and the length of time elapsed, these islands have furnished seven million tons of guano, whose value may be estimated at one billion dollars. The deposit reached a great depth, being usually more than 90 feet thick, and in some places it even reached 180 feet. In order to load it upon the boats, a quay was constructed in one part of the island. Since 1870, however, all the guano has been removed, and the island has become deserted. One thing of interest remains, namely, the seals, which are very abundant here. According to M. Lucas, who has lately visited the islands, the *Otaria jubata* is found in large numbers. There are many caverns which open directly into the water, and it is in these that the seals congregate to take their repose. It is difficult to capture them, however, on account of the shade of the islands.