

A FEED-WATER APPARATUS FOR BOILERS.

An invention patented by John S. Carter, of 483 Fargo Avenue, Buffalo, N. Y., provides an ingenious feed-water apparatus in which the exhaust steam from the engine is made to heat the feed-water, and is at the same time condensed and returned to the boiler. Means for purifying the feed-water and for separating the oil from the exhaust steam are also provided.

Fig. 1 is a perspective view of the apparatus, with parts broken away to show the interior construction. Figs. 2 and 3 are cross-sections through different parts of the device.

The apparatus is inclosed in a cylindrical casing, in the bottom of which is a chamber provided with a

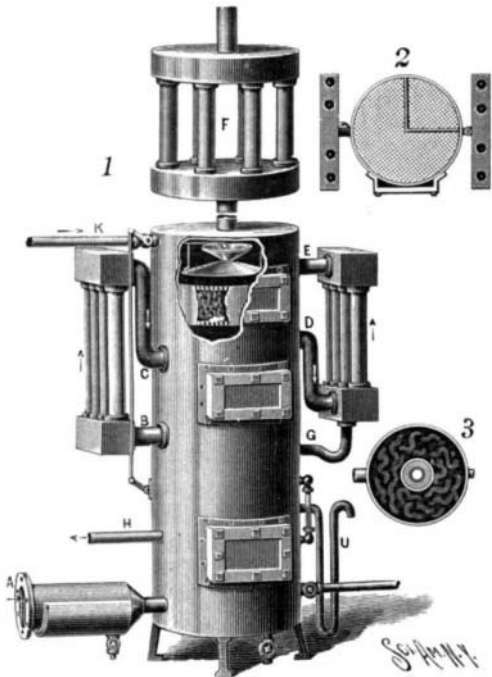

CARTER'S FEED-WATER APPARATUS FOR BOILERS.

blow-out pipe. The exhaust steam enters this chamber through a drum, *A*, fitted with a stationary screw serving to impart a spiral movement to the steam, whereby the oil is centrifugally separated. Leading up from the bottom chamber is a pipe (shown in Fig. 3) perforated near its upper end and provided with a baffle-plate, causing the steam to pass horizontally into a feed-water heating chamber. From this chamber the steam passes through a pipe, *B*, into a condenser comprising two boxes and a number of vertical glass condensing tubes. From the condenser the steam passes down through the pipe, *C*, to a second feed-water heating chamber, from which it emerges by way of the pipe, *D*. After passing through a second set of condensers the steam enters a third feed-water heating chamber in the upper end of the casing, by way of the pipe, *E*. The water of condensation from the second condenser is returned to the first feed-water heating chamber by a trapped or return pipe, *G*. From the third feed-water heating chamber the steam passes through a third condenser, *F*, provided with a vertical outlet pipe. The steam in passing through the various compartments is condensed, and the water of condensation runs back into the casing to be employed as feed-water.

The feed-water is led into the apparatus by means of a pipe, *K*, discharging upon a baffle-plate, from which it passes in a spray to the third feed-water heating chamber and is heated by the steam entering the chamber. The several feed-water heating chambers are separated from one another by means of filtering partitions formed of upper and lower screens, between which filtering material is packed. The water delivered from the baffle-plate passes down through the several screens and filtering partitions in a spray, is heated by the steam passing through the chambers, and finally reaches a reservoir from which it is supplied to the boiler, heated and filtered, by the pipe, *H*. The supply of feed-water in the reservoir is automatically regulated by a float-lever connected by a link with a valve in the pipe, *K*. A water-gage and a trapped overflow pipe, *U*, are also provided for the reservoir. The upper filtering plates or screens, as shown in Fig. 2, are made in two or more sections to facilitate ready removal when cleaning.

PROF. ERNEST HAECKEL, the great German Darwin exponent, was recently thrown from his horse in Rome and seriously injured. He is now 65 years of age.

A SIMPLE DRIVING MECHANISM FOR GINS.

An improvement in cotton-gin driving mechanisms has been devised by Colbert W. Brown, of Leonard, Tex., by means of which the brush is driven practically by the same belt which drives the saws, so as to impart uniform motion to the machine. To the saw-shaft a band-wheel is secured, which is connected by a loose band with a power-wheel mounted below the usual table of the gin-casing. On the brush-shaft a pulley is fastened, connected by a band with a second pulley journaled in a horizontal, forked arm pivoted to a vertical arm swinging on the casing. In order to hold the second band in contact with the first band, a spring is connected at one end with the horizontal, forked arm and at the other end with a screw moving through a stud on the gin-casing, and receiving an adjusting-nut. The tension of the spring may be varied by means of the screw-rod and nut. From the vertical, swinging bar extends a shifting-rod, provided at its outer end with teeth engaging a detent-plate secured to the casing.

When the power-wheel is in motion, the shifting-rod is pulled out to bring the two bands into engagement, and is held in adjusted position by means of the detent-plate. When the first band has been sufficiently tightened, the band-wheel on the saw-shaft and the pulley on the brush-shaft will both be simultaneously rotated, thereby securing an evenness of motion which adds much to the efficiency of the gin.

THE "MAESTRO," A NEW PLAYING ATTACHMENT FOR ORGANS.

The "Maestro" is an instrument for correctly rendering, with the aid of an organ, the productions of great composers without necessarily having any knowledge of music. It is not very difficult to play on musical instruments, but it is most difficult to play well, and there are many who are fond of music who wish to gratify this taste without the expenditure of years of practice which have hitherto been necessary. To all such the "Maestro" will be a welcome boon. The instrument is rightly named, for it is, indeed, a "master player," rendering the most difficult music in an acceptable manner, and it also educates the musical taste of the public and helps the beginner who is anxious to become properly educated in music.

The instrument consists of a handsomely finished case, which fits over the keyboard of any organ, and all of the mechanism is contained in this case. It is built in the most substantial and workmanlike manner, in different sizes, in order to fit any standard organ. Brass sockets are attached to the extremities of the keyboard of the organ; screw pins secure the "Maestro" to it, making the alignment and adjustment perfect.

The instrument is manipulated by the turning of the crank shown on the right, but if desired a water or electric motor can be employed. The best results, however, are obtained by turning the crank by hand, as this gives control over the expression and the music is marked to guide the player, so that in no sense can it be called "machine music." The function of the crank is three-fold; first, it serves to wind the roll of music from the reel on to the feed roller; second, it winds up the spring by means of a pinion on the shaft

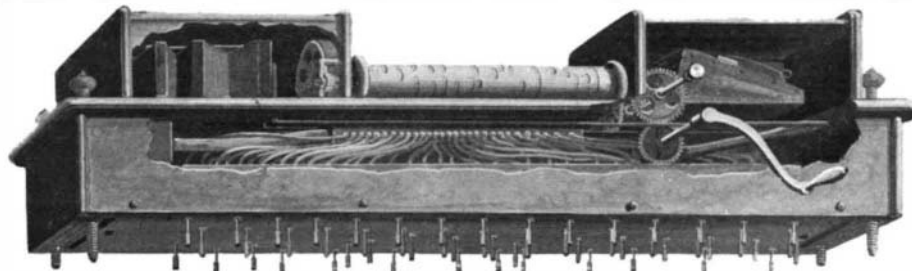

DETAIL OF THE PLAYING MECHANISM.

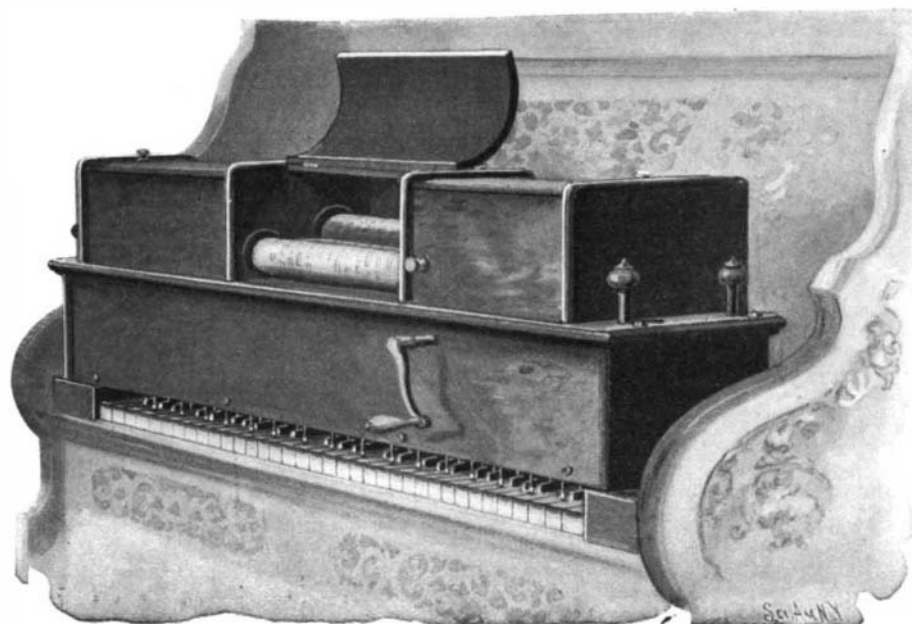

THE "MAESTRO," A SELF-PLAYING ATTACHMENT FOR ORGANS.

of the reel holder, the power stored serving to wind back the music on to its reel after it has been wound on the feed roller as played; and third, it serves to operate the bellows which exhaust the air from the plungers governing the keys.

The "tempo" is also controlled by the speed of the crank. The crank shaft terminates in a miter gear meshing with a similar and larger gear attached to the shaft of the feed roller, serving to actuate it to wind the music from the reel over the bridge which controls the plungers. The roll of music is inserted in the front

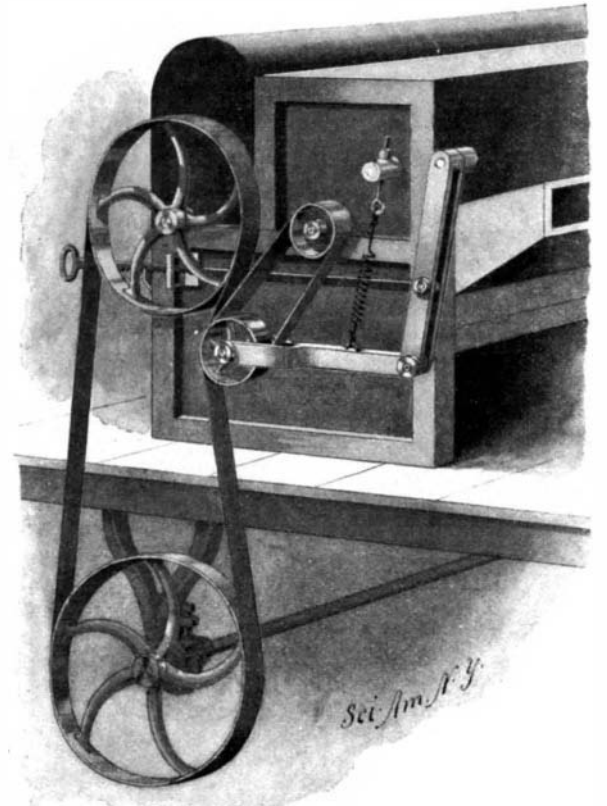

BROWN'S DRIVING MECHANISM FOR GINS.

of the instrument and is unrolled sufficiently to attach it to the feed roller, which winds it up as the music is played. When the piece is finished, the miter gears are thrown out of engagement by means of the pin shown just below the crank and the music is automatically wound on its reel by means of the spring shown on the left, which is wound up by the turning of the reel, the bearing of one end of which is square and adapted to enter a socket in the pinion shaft of the spring train. On the crank shaft is also a toothed wheel which meshes with another wheel to which a pitman is attached. The latter translates the rotary into rectilinear motion and operates the duplex bellows at the left end of the instrument through long sliding connecting rods. The bellows is connected with a reservoir bellows at the right end which serves to equalize the air vacuum.

The bridge consists of a hollow box whose top is perforated by a series of ports which are directly in the path of the dots and dashes in the music strip. A groove extends across the bridge and connects with each air duct by a small aperture; this groove is in turn connected with the vacuum chamber, which is placed at the bottom of the playing mechanism. The vacuum chamber at the bottom is common to all diaphragms which control the plungers. Every note is controlled by a rubber-covered plunger which slides through air-tight nipples and depresses the key, when the proper note is played by means of the music strip. The plungers are connected to diaphragms which move up and down in the body of the lower part of the playing mechanism. The top of each diaphragm is connected with a particular section of the bridge by a small rubber tube. The operation in brief is as follows: A vacuum is constantly kept up by the bellows keeping the plunger out of contact with the keys. This vacuum is constant while the paper passing over the bridge is unbroken, but the instant a perforation opens a port, air is admitted, and as we have already seen, there is also a vacuum at the bottom of the diaphragm by reason of the open passageway which is common to all the diaphragms. Consequently the pressure of air assisted by this vacuum forces the diaphragm down, sounding the proper keys. The mechanism is so simple that it is not likely to get out of order. The construction is very