

# SCIENTIFIC AMERICAN

[Entered at the Post Office of New York, N. Y., as Second Class Matter. Copyright, 1899, by Munn & Co.]

A WEEKLY JOURNAL OF PRACTICAL INFORMATION, ART, SCIENCE, MECHANICS, CHEMISTRY, AND MANUFACTURES.

Vol. LXXX.—No. 2.  
ESTABLISHED 1845.

NEW YORK, JANUARY 14, 1899.

[\$3.00 A YEAR.  
WEEKLY.]



The Facade—Total Length of Station Front, 2,190 Feet.

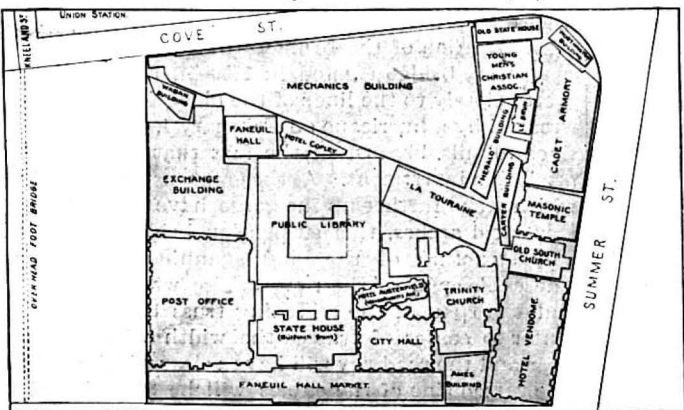

Twenty-four Boston Buildings Included within Station Site.

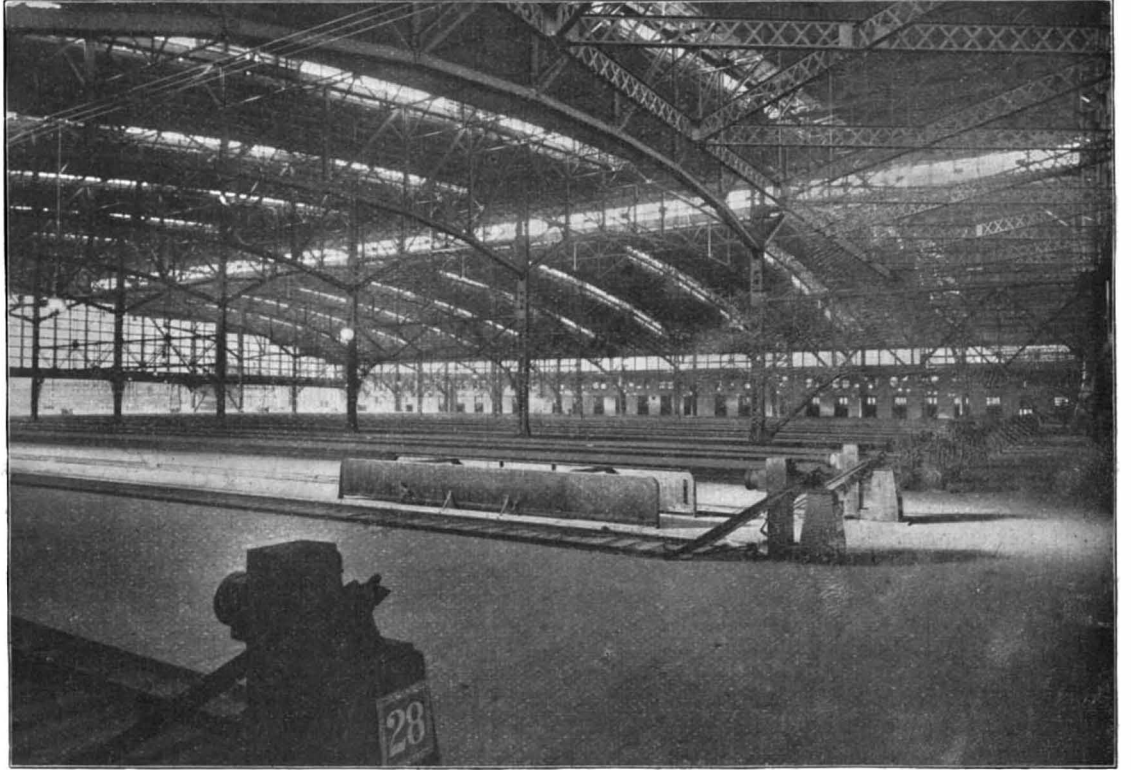

The Great Train Shed, 602 Feet Long by 570 Feet Wide—Twenty-eight Tracks.  
Total Area of Train Shed and Headhouse Site, 13 Acres.

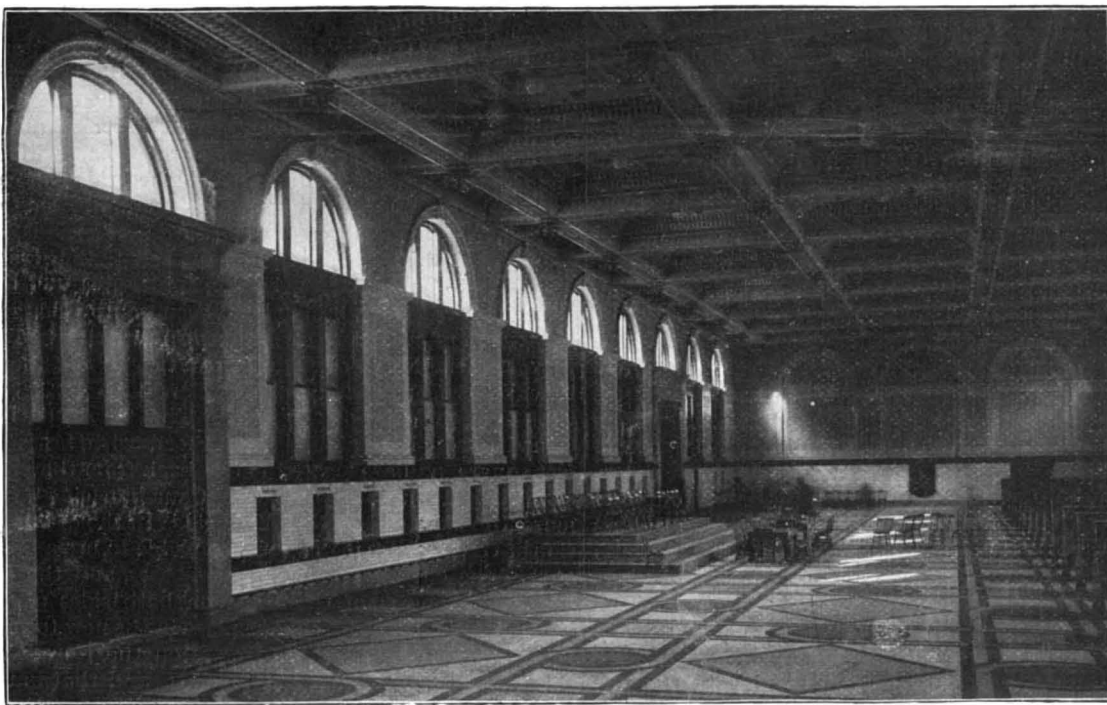

Main Waiting Room, 65 Feet by 225 Feet.



Subway for Suburban Tracks, and the Power Buildings.

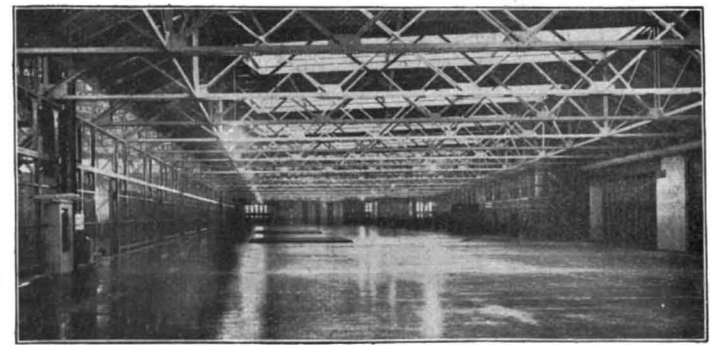

The "Midway" between Waiting Rooms and Tracks.

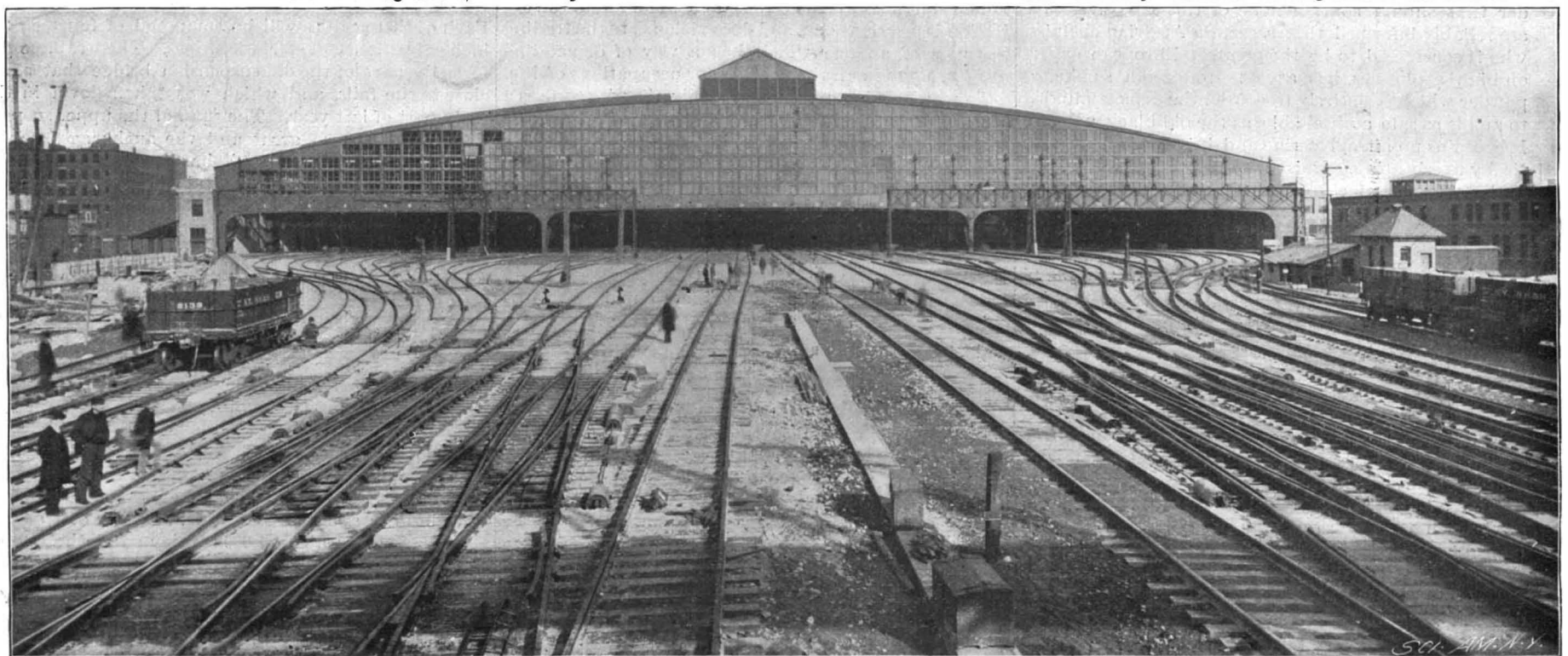

View of the Tracks, Signal Bridges, and Train Shed from the Yard.

THE NEW BOSTON TERMINAL STATION.—[See page 21.]

# Scientific American.

ESTABLISHED 1845.

MUNN &amp; CO., - - - EDITORS AND PROPRIETORS.

PUBLISHED WEEKLY AT

No. 361 BROADWAY, - - NEW YORK.

## TERMS TO SUBSCRIBERS.

One copy, one year, for the United States, Canada, or Mexico ..... \$3.00  
 One copy, one year, to any foreign country, postage prepaid, £0 16s. 5d. 4.00

## THE SCIENTIFIC AMERICAN PUBLICATIONS.

Scientific American (Established 1845).....\$3.00 a year.  
 Scientific American Supplement (Established 1876)..... 5.00 "  
 Scientific American Building Edition (Established 1885)..... 2.50 "  
 Scientific American Export Edition (Established 1873)..... 3.00 "

The combined subscription rates and rates to foreign countries will be furnished upon application.  
 Remit by postal or express money order, or by bank draft or check.

MUNN &amp; CO., 361 Broadway, corner Franklin Street, New York.

NEW YORK, SATURDAY, JANUARY 14, 1899.

## THE IDEAL SMOKELESS POWDER.

Great as are the advantages of the best forms of nitroglycerine and guncotton smokeless powder, there is not one of them that can be called an ideal powder. They all suffer from an inherent and ineradicable defect, due to the presence of the nitroglycerine and the fact that its explosive qualities are affected by changes of temperature. The best of these powders might be considered ideal explosives, provided they were always used at exactly the right temperature; but they never or rarely ever are.

When it is stated that 19.5 pounds of cordite fired behind a 100-pound projectile in a 50-caliber 6-inch gun will produce a muzzle velocity of 2,642 feet a second, the statement is not altogether complete; since one of the elements effecting these results has been omitted—or rather, it is supposed to be understood. Strictly speaking, these results can only be obtained if the powder at the moment of firing is at the normal temperature of the atmosphere. If its temperature is lower, as it would be in the Arctic regions, the velocity will be lower, and if it should be higher, as during an engagement in the tropics, the velocity will be higher. Now between these extremes of cold and heat there will be a difference of velocity which will interfere with the accuracy of the gun; for the sights are adjusted for the velocities due to the powder when fired at normal temperatures.

The pressures, moreover, are even more liable to change than the velocities. It frequently happens that a gun becomes quite hot from firing or from being exposed to the rays of the sun. While in this heated condition a charge may be inserted and, for some reason, allowed to remain for some length of time in the chamber before being fired. The heat of the gun is imparted to the powder, and in this heated condition it is liable to produce abnormally high pressures, and may even detonate and destroy the weapon. It is a fact that in some makes of machine guns serious accidents have resulted from leaving the piece loaded for a few minutes when the gun was overheated.

These troubles are entirely due to the nitroglycerine, and they are inseparable from any powders that include this powerful agent as one of the constituents.

For these reasons several of the European nations have always opposed the use of nitroglycerine in any form, and a vast amount of experimental work has been done in the hope of producing a smokeless powder that should contain none of this explosive. We are reliably informed that a certain Austrian chemist, who is considered to be the greatest European expert on high explosives, has at last produced a smokeless powder which is entirely free from the defects alluded to and is as safe and reliable as the old black powder. It contains no nitroglycerine and it is affected very little by overheating. It is not only very effective, but it can be manufactured much more cheaply than smokeless powder of the ordinary type.

Our informant, who is perhaps the most noted expert in rapid-fire weapons in Europe, states that the discovery has produced a sensation in naval and military circles, and that great expectations are entertained regarding the new explosive, regarding which particulars will be made public early in the year.

## FAILURE OF THE GATLING CAST-STEEL GUN.

The idea that a cast-steel gun can be produced which will have the same ratio of energy to weight of gun as the hooped or wire-wound gun, and stand the test of continued firing, dies hard. The latest attempt to work out a proposition which our artillery experts regard as, in the nature of things, impossible was embodied in the 8-inch cast-steel gun of Dr. Gatling, for the construction of which Congress appropriated \$40,000. As we noted in a recent issue the gun was duly constructed according to the inventor's specifications and sent to the Sandy Hook proving-ground to be tested. A sum of \$18,600 was allotted by the Board of Ordnance and Fortification for this purpose, and it

was the intention to subject the weapon to three hundred rounds in all. These tests are commenced at the standard firing pressure used in the army guns of 37,000 pounds to the square inch, but before they are over it frequently happens that the pressures rise far above this figure, in some cases exceeding it by over 100 per cent. When a gun has stood three hundred rounds, during which the pressure may have risen as high as 82,858 pounds, as actually occurred in the case of the Brown wire gun, the ordnance experts do not hesitate to pass it as being perfectly satisfactory, as far as danger of rupture is concerned.

The Gatling gun had already resisted five rounds with ordinary charges in its first trials. During the second series of trials, which took place on January 4, ten rounds were fired with the same charges and pressures of about 37,000 pounds. At the tenth round of the series, or the fifteenth round for the gun, it failed completely, and is described as flying into many fragments.

On being interviewed, Dr. Gatling stated that the failure did not surprise him, because he was aware that there was a mishap at one stage of the manufacture. He avers that tests of the metal of the gun showed that the breech was considerably weaker than the muzzle of the gun, the defect being due to the fact that the breech was subjected to a high temperature for three days longer than it should have been. As a result, the strength of the breech compared with the muzzle was about as six to ten, the metal at the muzzle representing the strength which was designed to be secured for the whole gun.

If these are the facts, though we confess the statement needs elucidation, it is greatly to be regretted that the weapon was not rejected and another cast. Every one, and none more than ordnance officers, is anxious to know the exact possibilities of cast ordnance. The present failure, notwithstanding the alleged mishap in the manufacture, will tend to strengthen the prejudice which undoubtedly exists against the type.

## EDUCATION BY CORRESPONDENCE.

Elsewhere in our columns will be found a letter from a Russian correspondent, Mr. N. A. Shishkov, giving the rough outline of a new scheme of education which he desires to bring prominently into public notice, with a view to its general circulation and discussion. The writer will doubtless be remembered by many of our readers as the author of an article ("The Horrors of Hunger") describing the great famine in Russia, which appeared in the Nineteenth Century in 1892, and was largely instrumental in arousing the practical sympathy which was shown both in this country and Europe with the distressed Russian peasantry. Speaking broadly of the proposed scheme, without consideration of the difficulties of organization and detail which would be encountered in carrying it out, we think the spirit and purpose of Mr. Shishkov's ideas are to be commended. Work along somewhat the same lines has been started in this country in the schools and colleges of correspondence, which have proved to be so successful, and though their organization differs in important particulars from the present proposal, they are so nearly allied to it in principle as to afford reason to expect that education by correspondence, if carried out on an international scale, might, by the valuable benefits conferred, commend itself to universal favor.

The first and obvious question that will suggest itself to the average overworked and brain-weary citizen in this utilitarian age is: How could any one be expected without adequate compensation to devote valuable time to answering the many questions which such a scheme might bring? To the commercial mind, the objection is a serious one, and does violence to the trading instincts of an age which has a way of demanding *quid pro quo* in all the ventures or occupations of life.

To which it is sufficient to reply that it requires a broad intelligence, a liberal mind, and a progressive spirit to appreciate the actual benefits—should it prove to be practical—of all such schemes as that outlined by Mr. Shishkov.

Another and perhaps more serious difficulty would be that of diversity of language; for, unless the sources of income of the association were more fruitful than we think those suggested by our correspondent would prove to be, it would be impossible to maintain anything like the corps of translators that would be necessary to cope with an international correspondence of the magnitude which this association would presumably carry on. On the other hand, it is probable that one of the best results of the undertaking would be that it would greatly stimulate the mutual study of the three great languages, English, French, and German, adopted for the uses of the association.

It will, moreover, suggest itself to our readers that the need for such a medium of information is probably more apparent in the great country to which our correspondent belongs than in some others. Speaking for the United States, we can say that, in addition to the schools of correspondence above mentioned, there is a splendid field for the mutual exchange of information afforded by the press of the country. In the half century of its existence the SCIENTIFIC AMERICAN has devoted

a column or more of each issue to this form of instruction under the head of "Notes and Queries;" and by this medium and by letter some 5,000 items of information emanate from this office alone each year.

This method of conveying information is practiced in some degree by other journals throughout the country, and it is probable that the items thus secured by correspondence exceed in themselves and far exceed in the numbers of their readers those that would pass to and fro in a system of correspondence between individuals.

At the same time we fully realize that information by correspondence through the press is of a national and therefore somewhat local character; whereas Mr. Shishkov's scheme is formed on the broadest international lines.

## NEW SUSPENSION BRIDGE AT NIAGARA.

During the next three months a large force of men will be at work erecting a new suspension bridge across the Niagara River, a short distance above the village of Lewiston, on the New York side, and the village of Queenston, Ont., on the Canadian side. This bridge is to be built by the New Jersey Steel and Iron Company for the Lewiston Connecting Bridge Company and the Queenston Heights Bridge Company. The consulting engineer is L. L. Buck and the engineer R. S. Buck. James Stewart & Company had the contract for the substructure, which is about completed.

The location of the bridge will be on the site of a suspension bridge erected in 1850-51, and will adhere pretty closely to the lines of the old bridge, which was wrecked by a hurricane on February 1, 1864, and never since rebuilt, because of the fact that it was an unprofitable investment. As the great suspension bridges which stood further up the gorge have given place to new steel arches, this suspension bridge will be the only structure of the kind spanning the Niagara. The cable span of the new bridge will be 1,040 feet and the span of the stiffening truss 800 feet. From center to center of trusses the width will be 28 feet clear and the roadway will have a clear width of 25 feet. The versed sine of the cables will be 87 feet and the height of the superstructure above high water mark will be 65 feet. The height of the bridge above the tracks of the Niagara Falls & Lewiston Electric Road will be about 15 feet. The stiffening truss will extend about 4 feet above the floor and the only railing will be light strips of iron flats reinforced by oak half rounds. The floor will be of 2 inch oak plank laid crosswise. A single track for trolley cars will be laid through the center, the width of the bridge affording ample room for vehicles to pass on either side of the track. There will be no walk for pedestrians, as the point of the bridge's location is such that there is not likely to be much travel on foot.

The towers for the bridge have been completed, and are four in number, two on each side of the river. The towers on the New York side have a height of 26 feet, bases of 13 feet square, and they are located 28 feet back from the edge of the bluff. The towers on the Canadian side have a height of 18 feet, with bases 12 feet square, and are located 15 feet back from the edge of the bluff, the ledge on the Canadian side being more firm than on the New York side. In the construction of these towers it was found possible to use a great part of the old towers in the new bases, and the old inscription stones of the towers on both sides of the river were preserved and have place in the new towers. The new stone used in the towers on the New York side came from the Buffalo quarries, and that in the Canadian towers from the Queenston, Ont., quarries.

Four cables will form the main support of the bridge. Each of these cables will be composed of fourteen 2½ inch galvanized cast steel wire ropes. These cables once formed a part of the old suspension bridge that stood close to the falls, and which was taken down in the early part of last year. The span of the upper suspension bridge was so great and the anchorages so far back from the towers that it has been found possible to cut the old cables in half, and thus use them on the shorter span of this new bridge at Lewiston. However, when so cut they are hardly long enough to fill out the entire span and reach back to the anchorages, and for this reason about 75 feet at each end of the cable span will be made up of eye-bars. The cables will be anchored in solid rock about 150 feet back from the towers, the shafts to be filled with concrete. The suspended span will be connected to the river banks by two approach spans, the one on the New York side to be 34 feet 6 inches long and the one on the Canadian side to have a length of 19 feet 6 inches.

On each side of the river the bridge will have long approaches on which double tracks will be laid for electric cars passing on and off the bridge. These approaches are about 25 feet wide, and the one on the Canadian side is about 1,000 feet long and the one on the New York side about 800 feet long. Both approaches have face walls to prevent the native shale disintegrating under the weather. The approach wall on the New York side runs close beside the tracks of the Niagara Falls & Lewiston Electric Road. Its highest part is about 19 feet, and for 660 feet it drops

at a 1 per cent grade and then for 200 feet at a 2 per cent grade. The high part is laid in cement and the remainder is laid dry. These approach walls form the bridge landings. It is expected that the Niagara Falls & Lewiston Road will connect its tracks with the bridge on the New York side and the Niagara Falls Park & River Railway with the bridge at the Canadian end. This will make it possible for passengers to travel around the beautiful gorge without leaving their seats in the electric cars. Starting from the New York State Reservation, the trip would consist of crossing the river over the magnificent new upper steel arch in a car of the Niagara Falls Park & River Road; passing down that line along the top of the high bank on the Canadian side to Queenston, there crossing on the new suspension bridge to the New York side, where the tracks of the Niagara Falls & Lewiston Road would be taken back along the water's edge and up the bank to the point of starting, thus allowing passengers to view the river and banks from above and below, all forming a most delightful trip.

The capacity of the new suspension bridge is to be such that it will accommodate the heaviest of trolley cars, together with a uniformly distributed load of 40 pounds to the square foot over the entire structure. About 800 tons of metal will be used in its construction, and the cables will weigh about 200 tons. Connection between the cliffs will soon be made, and after the cables are strung, the work of erecting the superstructure will start at the New York State end and progress rapidly until the river is spanned. It is expected that the superstructure can be thrown across the river in sixty days, so that the bridge will be ready for travel next summer.

**THE GROWTH OF OUR OIL TRADE.**  
BY WILLIAM GILBERT IRWIN.

In the oil regions there always has existed and always will exist a speculative fever. The risks, the possibilities, the ebb and flow of fortunes, the periodic frenzies and the fluctuating prices of the product all add to the romance and interest of the oil fields, and help them to create their own atmosphere.

The story of the rise of this great industry has an absorbing interest. During the last half century hundreds of millions of dollars have been expended in opening this vast dormant source of wealth.

The latest available statistics (for 1896) place our annual production of petroleum at 60,960,361 barrels. The foreign product for the same year was 47,552,886 barrels, which makes a grand total production of 108,512,947 barrels. The value of this product is upward of one hundred million dollars, and after having passed through the refining processes and the complex processes of modern chemistry, this crude oil represents a myriad of diversified finished products of industry and its total value is enormous.

Like other similar branches of trade, all this vastness has sprung from the work of some farseeing genius and the work of some few pioneers who lived in the van of their time. Northwestern Pennsylvania can well claim the honor for the inauguration of the oil trade, and 1849 was the year of its birth. The existence of oil in Northwestern Pennsylvania and Western New York was known to the Indians from the earliest days. When first the French came to this region they were shown the oil springs, and the earliest English settlers were aware of the presence of those on Oil Creek. In the year 1819 the presence of petroleum was noticed in salt wells sunk along the Ohio. In the early days of the century a few gallons were occasionally gathered from the surface of springs and taken to Pittsburg by the lumbermen with their rafts, and the product became widely known under such names as "Seneca oil," "British oil," "Genesee oil," etc. In the early forties Samuel Kier began the preparation and sale of the oil, and, bottled and prepared for medicinal purposes, it attained a wide sale. His supply was obtained from an old salt well at Salina, on the Kiskiminetas.

But as yet the product had no real commercial value. The crude oil was not fit for lighting purposes on account of its dark smoke, and its use for heating purposes was also impossible. As a lubricant it was used only in a small way. The first lease of oil lands, with a view to putting down an oil well, ever made in this country, was that of a tract containing an old oil spring, located in Cherrytree Township, Venango County, Pa., and it was made by J. D. Angier to Brewer, Watson & Company, in the year 1853. The lease was for five years.

But this venture was not destined to have an immediate success. In 1854 Dr. F. B. Brewer, a son of the senior member of this pioneer oil firm, went to Hanover, Mass., taking with him a bottle of the oil for medicinal purposes. There Dr. Brewer presented the oil to his relative, Prof. Crosby, of Dartmouth College, and shortly afterward it came to the notice of George H. Bissell, a New York lawyer. A visit to the spring was the result, and Bissell and his partner, Jonathan G. Eveleth, purchased from Watson, Brewer & Company 105 acres of the land they had leased. In the same year (1854) the Pennsylvania Rock Oil Company was incorporated under the laws of the State of New York,

but, owing to legal complications and the prostration of the money markets, which had taken up the stock, the project was delayed for several years.

Up to this time the idea of boring for oil had not been thought of; but in 1856, when Bissell went to see Kier, and learned that his preparation was obtained from a salt well, 400 feet deep, the idea at once came to his mind, and in 1858 Edward Drake, a stockholder in the Pennsylvania Rock Oil Company, was engaged to drill a well. In the meanwhile, the Pennsylvania Rock Oil Company was succeeded by the Seneca Oil Company, of which concern Drake became president.

Saturday, August 28, 1859, is a day justly celebrated in oil country history, for on that day oil was struck in the Drake well at a depth of 70 feet. Two days later the well was producing 20 barrels per day. This was the beginning of the oil excitement, the history of which has scarce a parallel in history. The story that oil was being pumped from the earth as freely as water was at first scouted, then accepted as a curious phenomenon, and finally it came to be believed as a fact.

When it became known a little later that oil gushed from the earth of its own power by the hundreds of barrels, the excitement became a wild mania. The desire to speculate in oil and oil lands became general. The sober farmer who received fabulous prices for his poor farm joined in the frenzy. Fortunes of gigantic proportions were won and lost in a short space of time.

Titusville grew in a few weeks from a town of 100 people to a city of 15,000. The region of the oil excitement extended rapidly, until nearly the entire Northwestern Pennsylvania was one vast oil field. Everywhere towns and cities sprang up as if by magic. While hundreds of these were mushroomlike and have long ago been effaced from the earth, others were stable and remain to this day as memorials to the rise of this great industry. In time great oil fields were opened up close to Pittsburg. Then the Washington and Greene County fields in Southwestern Pennsylvania were brought in, and later the West Virginia fields were opened up. The Lima field of Ohio and the fields of Indiana in their turn were opened up, and other States joined in the procession.

For over a quarter of a century from the time of its opening the New York and Pennsylvania region of the Appalachian field stood alone in the production of petroleum, and there was not a producing oil well outside the Appalachian field until the opening of the Lima field, begun in the year 1885. In 1849 about 2,000 barrels of oil were produced about Titusville, Pennsylvania. The production of that region in the year 1860 was 500,000 barrels, and ten years later Pennsylvania was producing upward of 5,000,000 barrels annually. The production of the New York and Pennsylvania region in the year 1880 was 26,027,631 barrels, and in 1882, when this region produced 30,053,500 barrels, the climax was reached. The production of this region in 1890 was 28,458,208 barrels and in 1896 20,484,421 barrels were produced. Titusville, Oil City, Franklin, Pithole, and other towns have successively been the center of this oil country, and ever since the first well was put down there has been a constant shifting of the center of the industry. Within the last decade the oil territory developed about Pittsburg and in Southwestern Pennsylvania has virtually made Pittsburg the center of the oil business, and the development of the West Virginia region has assisted Pittsburg in retaining her mastery.

While oil in considerable quantities was produced in West Virginia as early as 1875, it was not until the year 1885 that the oil business in that mountain State was really begun in earnest. West Virginia's production in that year was 91,000 barrels. In 1890 that State produced 492,578 barrels, and the next year the Sistriville region was brought in, and the production of that State was increased to 2,406,218 barrels, and the production for 1896 was 10,019,770 barrels. The Southern Ohio region, included in the Appalachian field, was an early oil-producing section. In 1880 it produced 38,490 barrels, and in 1885, when the Lima field was developed, Ohio produced 661,580 barrels. In 1890 Ohio produced 16,124,656 barrels and in 1896 she led all other States, having a production in that year of 23,941,169 barrels. California produced oil as early as 1875. The California field is located in the southern part of that State. Its production in 1880 was 40,552 barrels. In 1890 California produced 307,360 barrels and in 1896 its production was 1,252,777 barrels. The first recorded production of the Colorado field was in 1897, when the production was 76,295 barrels. In 1890 that mountain State produced 368,842 barrels. Its production in 1892 was 824,000 barrels, and in 1896 this had dwindled to 361,450 barrels. The production of Kentucky and Tennessee never was large, and very little oil is now produced in these States. The Indiana part of the Lima field was developed in 1889, and that year Indiana produced 33,375 barrels. New regions were developed in 1893, and Indiana's production in that year was 2,335,293 barrels and in 1896 it produced 4,680,732 barrels.

Thus have we given in detail the opening and pro-

duction of the oil fields of our country and the production of the different States at different periods in the growth and development of the industry. It will be seen that the Lima and Indiana fields now lead all others, having in 1896 produced 33,970,222 barrels, against the 25,255,870 barrels produced in the Appalachian field. It is only when we pause to consider the magnitude of the work required to extract from the bowels of the earth the great latent store of Nature's contribution to modern industry that the magnitude of the oil trade becomes fully settled in the mind. There are to-day not less than 20,000 producing wells in this country, and every year thousands are being added to these. The "dry holes," it must be remembered, far outnumber the producing wells, and in these millions of dollars are lost every year.

America led in the opening of her oil fields. Since the development of the industry in this country oil-producing fields have been developed in foreign countries. More than two thousand years ago petroleum in its crude state was known to the Greeks and Romans, and for centuries the springs and wells of the Rangoon district, on the Irrawaddy, have supplied the entire population of British India. Baku, now the center of the great Russian oil fields, has supplied Persia with artificial light, and for more than two centuries Parma and Modena have furnished Italy with petroleum. The product is found in Trinidad and Cuba, it is to be seen floating upon the surface of the water in the vicinity of volcanoes, and old Vesuvius has her oil springs; but no attempt at the utilization of this fuel product was made in the old world until after it had undergone its early stages in our own country, and even to this day we lead all the world in the production of petroleum. Against our production of 60,960,361 barrels for the year 1896 the entire foreign product was but 47,552,866. Russia leads the foreign countries with 39,882,122 barrels and the production of the other countries for the year 1896 was as follows: Austria-Hungary, 2,443,080; Great Britain, 1,500,000; Canada, 801,725; Japan, 1,324,850; Java, 505,029; Germany, 145,061; India, 371,830; Italy, 20,841; Peru, 15,000; Sumatra, 4,380,000.

The large production of mineral oils in other parts of the world, while it has not reduced our exportation, has probably reduced the prices which our producers and exporters have been able to realize. The exports of oil in the year 1898 were practically double those of 1888 and three times those of 1878, but the money received for them was only about 25 per cent greater than that received either in 1878 or 1888. The total receipts for the 1,034,269,676 gallons of oil exported in 1898 were \$56,126,578, while for the 578,351,638 gallons exported in 1888 the receipts were \$47,042,409, and for the 338,841,303 gallons exported in 1878 the receipts were \$46,574,974. The average export value of refined illuminating oil was, in 1872, 24.9 cents per gallon; in 1878, 14.4 cents per gallon; in 1888, 7.9 cents per gallon; and in 1898, 5.2 cents per gallon; having thus fallen from 24.9 cents to 5.2 cents from 1872 to 1898. Notwithstanding this steady fall, the production and exportation continue to increase, the exports having increased over 60,000,000 gallons in the past year over that of the preceding year, and over 100,000,000 gallons over that of any earlier year, while the production for 1897 was 2,528,067,984 gallons, against 2,033,331,972 in 1894; 1,476,867,546 in 1890; 1,017,174,396 in 1885; 836,394,132 in 1880; and 510,825,588 in 1876. Thus, while the price has been steadily and rapidly falling, the quantity produced and the quantity exported have as steadily and rapidly increased. The production in 1897 was five times that of 1876 and the exportation of last year nearly five times that of 1876. Great as the fall in price has been, the exports of illuminating oil bring over a million dollars a week into the country and have in the past twenty years added a round billion of dollars to our foreign sales.

Our oil products reach every continent and all the principal islands of the earth. They go to every European country, to China, Japan, Australia, Egypt, Transvaal, and Brazil. With every year our trade in oil, both foreign and domestic, is increasing, and, unlike the gas fields, our oil fields are so far from exhaustion that that event has not yet been given a serious consideration.

EVERY farmer of the State of New York may now avail himself of the privileges of the Nixon bill providing for the university extension of agricultural knowledge by addressing the Reading Course, College of Agriculture, Ithaca, N. Y., for plans of the Farmers' Course of Reading during the winter. Several thousand farmers are now following the course. The topics relate to the farmers' occupation. After the reading course a discussion with the College of Agriculture will follow, and suggestions are given for the formation of reading circles. A great deal has been said about the practical nature of scientific agriculture, and in these times of fierce competition the strong are constantly becoming stronger, and no farmer should neglect any chance of improving himself. Under the Nixon bill there is no expense to those taking up this course, as the reading matter is furnished.

### A NEW LINK VALVE-GEAR.

In the accompanying engraving we present a link valve-gear for steam-engines and other machines, which is designed to produce a complete center action by placing the eccentric and valve in a true line at all times, thereby preventing undue friction and pinching of the parts under heavy pressure. Fig. 1 of the annexed illustrations represents the valve-gear in perspective. Fig. 2 is a sectional plan view. The link valve-gear is provided with a yoke formed at its upper end with a pin. This pin is adapted to be engaged by a shifting-lever to move the link either into an uppermost or a lowermost position, according to the desired position of the valve. On the side-arms of the yoke are arranged aligned bearings engaged by trunnions. These trunnions have their plates secured to the outer faces of link-arms, arranged in pairs and fastened together at their lower and upper ends by cross-pieces. The link-arms of each pair are spaced to form the usual segmental slots engaged by sectional boxes. These boxes slide on the link-arms and are engaged by a pin carried by the valve-stem and secured in place by a set-screw. On the forward sides of the link-arms, lugs are formed, which receive pivot-pins for the heads of the two eccentric-rods, thus giving the usual rocking motion to the links in order to actuate the stem and hence the valve. It will be observed that the yoke,

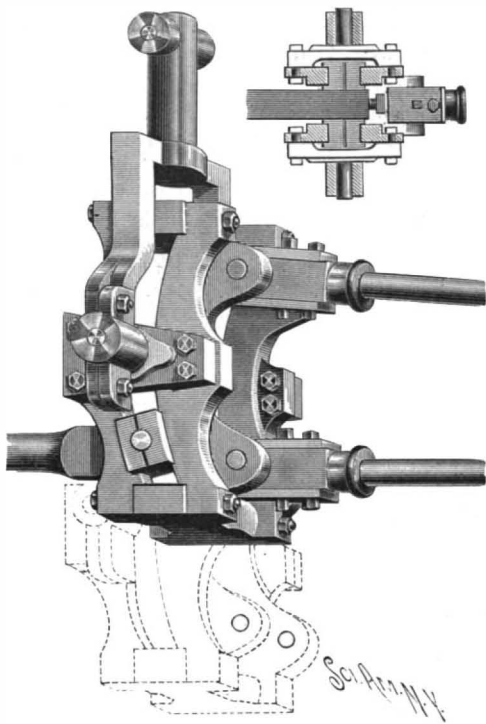

ROST'S LINK VALVE-GEAR.

besides being capable of turning, can be raised or lowered into the position shown in dotted lines in Fig. 1, in order to change the position of the valve as the boxes slide in the link-arms to shift the valve upon rocking the link-arms further. The valve-gear is the invention of John A. Rost, Axtell, Neb.

### Coal for Our War Vessels.

The Navy Department has now decided to keep at all times a stock of about one-half million of tons of the best steaming coal procurable. The war with Spain demonstrated the enormous importance of coal, and the distribution of this vast stock will be done with the advice of the best naval strategists. About 300,000 tons will be kept on the Atlantic and probably 120,000 tons will be used on the Pacific. The expense of purchasing and transporting this vast quantity of coal will be large and the apparatus which will be installed for the expeditious coaling of war vessels will be most elaborate. It has been decided that 25,000 tons of coal will be kept at Manila, 10,000 tons at Guam, 25,000 tons at Honolulu, 10,000 at Pago Pago, 25,000 tons at San Francisco, 25,000 tons at Brewerton, Puget Sound. On the Atlantic coast the coal supply will be approximately as follows: Havana, 25,000 tons; Santiago, 10,000 tons; San Juan, Porto Rico, 25,000 tons; Key West and the Dry Tortugas, 50,000 tons; Port Royal, S. C., 25,000 tons; Norfolk, Va., 5,000 tons; Washington, 1,000 tons; League Island Navy Yard, 5,000 tons; New York Navy Yard, 5,000 tons; New London, Conn., 25,000 tons; Boston, 15,000 tons; Portsmouth, N. H., 10,000 tons; Frenchman's Bay, Me., 15,000 tons. In addition to this vast and judiciously stored supply it is believed that the naval authorities can at any time command 50,000 tons of coal at either New York or Hampton Roads. With this splendid stock of coal the Atlantic coast will be efficiently protected compared with its position before the war.

The government now has seventeen colliers, which will be capable of coaling a fleet which would pass around the South American continent in case neutrality were enforced on countries contiguous to the coast. The entire coaling capacity of the colliers is estimated at about 50,000 tons. As some of the coaling stations are a couple of thousand miles apart, it is little wonder that longing eyes are often cast at comparatively unim-

portant islands which would furnish excellent coaling stations.

### Moosic Mountain to be Tunnled.

Residents along the Delaware and Hudson Canal, who have been greatly depressed over the proposed abandonment of this waterway, are encouraged by the news of the great railway project of the Scranton, Honesdale and Eastern Railway to tunnel the Moosic Mountain a distance of one and three-quarter miles, a coal road to be constructed from the Lackawanna River to the Hudson. The road will start near the station of Frank Hollenbeck and run through the proposed tunnel to Honesdale, Pa., whence it will continue to a point on the Delaware River at or near the aqueduct at Lackawaxen. From there it will follow the line of the canal, with the exception of straightening out the crooked places, to Port Jervis and from there will run to Rondout. The road will be 138 miles long and the grades will be such that they will permit of hauling a long train of coal cars from the coal regions to tidewater or to the New England States without breaking bulk. The road will be down grade all the way.

It is thought that the new enterprise will greatly reduce the selling price of coal to dealers along the Hudson River. A contract for the construction of the Moosic Tunnel has been given to a Chicago firm. The tunnel will be 8,642 feet long and 14 feet high and its width will be 14 feet. It is proposed to complete the tunnel within one year from January 1, 1899, and the cost will be \$421,730. The work will be commenced simultaneously at both ends and four hundred workmen will be employed.

### A NOVEL CHAINLESS BICYCLE.

A chainless bicycle recently made its appearance in Princeton, N. J., which, on account of its novel construction and ingenious driving-mechanism, has attracted no little attention.

From the accompanying illustration it will be seen that the driving-mechanism consists essentially of a small spur pinion mounted on the axis of the rear wheel, and meshing with a large spur-gear pivoted upon the frame of the bicycle. This large spur-gear is connected by means of a driving-rod with one of the pedal-cranks.

The pedal-crank in question is bent and has a pivot-pin for the driving-rod located at a short distance from the pedal-shaft and in a direction from the pedal-shaft substantially at right angles to the direction of the pedal-pin from the shaft. To this pivot-pin is connected the driving-rod, which at its other end is secured to a crank upon the large spur-gear.

The driving-rod, in order to overcome dead centers, and to insure the rotation of the cranks in the proper direction, is provided near its middle with fulcrum rollers having shifting pivotal connection with sockets on the frame. By reason of this construction, the driving-rod acts as a lever when the cranks are on dead centers. When the bicycle is in motion, the pedals will rotate in a forward direction and will carry with them the front end of the driving-rod; the rollers will alternately engage their sockets on the frame; and the rear end of the driving-rod, and consequently the large spur-gear, will rotate backwardly, or in a direction opposite to that of the pedals.

The object of the peculiar construction of the pedal-shaft with which the driving-rod is connected is, that the pedal-cranks and the short cranks connected by the driving-rod shall all be simultaneously on dead centers, from which construction it also follows that the cranks will be in the most favorable position for the transmission of power at the same time.

The driving-rod is formed in two pieces adjustable longitudinally, so that the rod may be varied in its length and accommodated to different bicycles.

The inventor of this mechanism, Mr. William C. Duryea, informs us that the bicycle has been in use for more than a month, and runs with remarkable ease and freedom from noise.

ACCORDING to Lurmann, carborundum (silicium carbide) can be employed as a substitute for ferrous silicium in the production of steel, considerable quantities of carborundum being already used for that purpose.

### AN IMPROVED RAIL-JOINT.

A useful improvement in rail-joints has been patented by William E. Smith and John H. Adams, of Telluride, Col., in which improvement fish-plates are employed, so joined that the contiguous ends of the rails are braced and fastened between the fish-plates.

Of the accompanying illustrations, Fig. 1 is a perspective view of rail-sections joined together by the improved means; Fig. 2 is a perspective view of a fish-

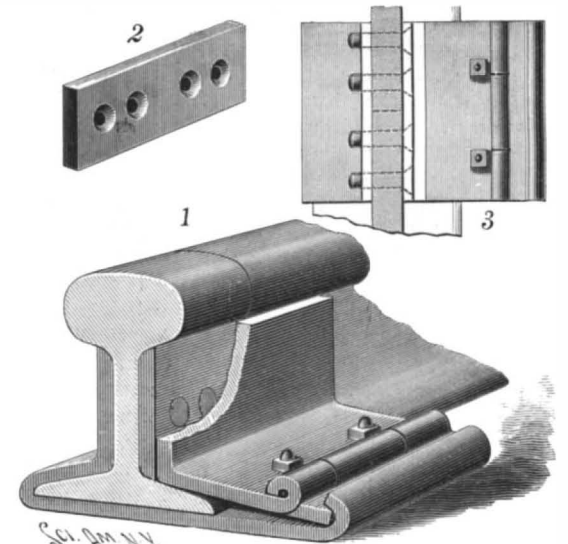

NOVEL RAIL-JOINT.

plate employed; and Fig. 3 is a plan view of the improvement with the rails in section.

Through the rail-sections pins pass, which serve the purpose of the usual bolts and which have their heads seated in openings of the fish-plate countersunk, shown in Fig. 2. The fish-plate lies against one side of the rail with the pins projecting through the rail and through another fish-plate formed by the upturned end of a chair. The chair in question extends beneath the rails, and has at its side edge an upwardly and inwardly turned flange, as shown in Fig. 1.

The pins passing through the rail are held in place by means of a long hinge-section formed with a presser-plate and joined by a pintle to a coacting hinge-section adapted to bear on the chair-flange. Bolts pass through the long hinge-section and the chair and by their means the long hinge-section can be drawn down. By the action of the hinge, which is essentially that of a toggle, the presser-plate is forced against the heads of the pins, to hold the pins from displacement. The presser-plate and the fish-plate on the other side of the rail are forcibly drawn toward each other and the sides firmly clamped, thus making a secure connection.

The improvement, it will be observed, does away with the bolts and nuts ordinarily used on fish-plates.

### Fermentation Without Living Cells.

As a result of the investigations of Prof. Buchner, of Tübingen, another of the fetiches of old chemistry is destroyed, namely, that living cells are necessary to fermentation. Prof. Buchner, according to Science, grinds yeast with quartz sand in order to disrupt the cells, and submits the moist mass to a pressure of 500 atmospheres. The liquid contents of the cells are entirely removed and the cells totally disrupted. The



A NOVEL BICYCLE DRIVING-GEAR.

filtered liquid is of a clear or slightly opalescent, yellowish color, retains the odor of yeast, contains considerable carbon dioxide and some albumen. Most interesting is the behavior of the yeast juice toward sugars, fermentation being set up much more quickly than by yeast, and proceeding much faster. The gas evolved is almost pure carbon dioxide. When carefully dried at a low temperature, the fermenting principle is not destroyed, and it is possible that, when desiccated, the activity of the ferments may be preserved indefinitely.

**THE NEW BOSTON TERMINAL STATION.**

With the commencement of the present year the huge terminal station which has been built to accommodate the many and important railroads which enter the city of Boston from the south was thrown open

Although the trainshed is 570 feet wide and capable of accommodating over thirty tracks, if they should be laid in the usual manner, the engineers foresaw that the estimated total of between two and three thousand trains a day could not be run into and out of the sta-

and the latter upon two loop lines which should be laid some 17 feet below the level of the main platform. This is the plan of the station as finally adopted and built. The long distance and express trains are handled upon 28 parallel tracks on the main floor, the trains being switched into and out of the station in the usual manner. The suburban traffic enters and leaves the station by an inclined subway (see illustration), which leads down beneath the main floor, where the tracks form a couple of separate loops, swinging around underneath the main platform and leaving by the same incline as that by which they enter. Two other important features are the use of separate platforms for baggage and express matter and the use of some other motive power than that of steam

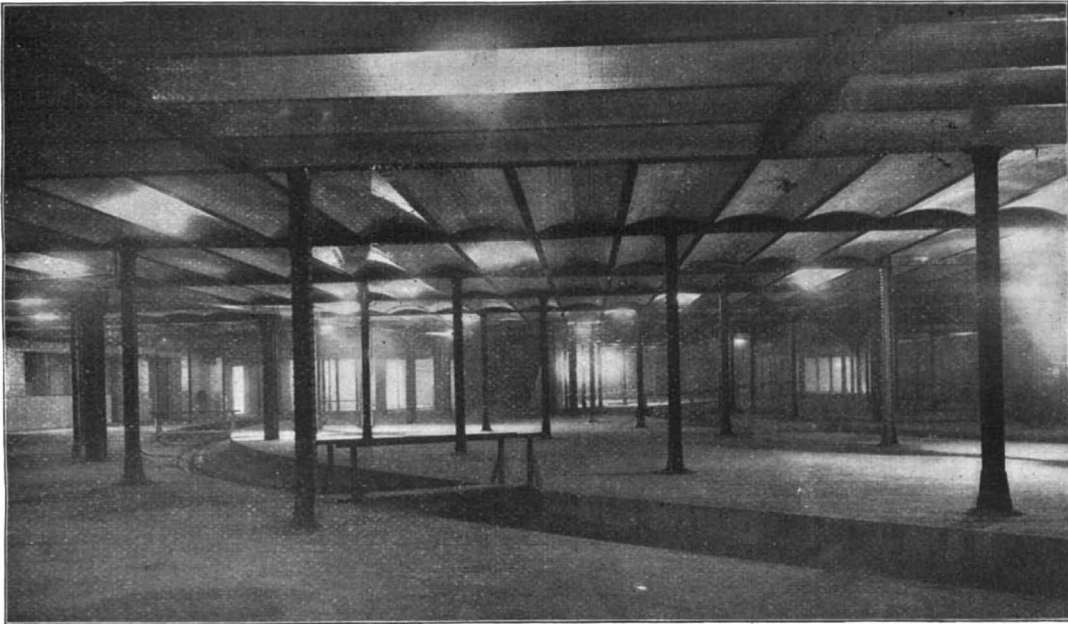

**THE SUB-STATION FOR DEPRESSED SUBURBAN TRACKS, BOSTON TERMINAL STATION.**  
Long distance tracks are on the main floor above.

for service, and the city can now boast of possessing a railroad station which is not only by far the largest structure of its kind in the world (its capacity being indeed fully double that of any other station), but which possesses many radical and improved features that are entirely novel in a building of this kind.

Upon the railroad routes within 50 miles of Boston, about 50,000,000 passengers are carried to and from the city every year, the total being about equally divided between the stations in the northern and the southern sections of the city. The approximate population within the suburban or 50-mile limit of the city is 2,392,000. Within the same limit around Philadelphia it is 2,289,000; around Chicago, 1,188,000; and around New York, 4,754,000; New York being the only city that exceeds Boston in this respect.

The express and suburban traffic that enters Boston on the south has hitherto been carried by four systems: The Providence division of the New York, New Haven and Hartford, the Old Colony, the New England, and the Boston and Albany. This traffic, which as we have stated amounts to one-half of the 50,000,000 passengers annually carried to and from Boston, has been handled in the four stations of the roads above mentioned.

The Boston Terminal Station has been built for the purpose of bringing all of this traffic into the heart of the city over one set of tracks and handling it in one mammoth depot. The convenience and economies resulting from such an arrangement are too obvious to need recapitulation here.

It was realized at the outset, when the engineers were engaged upon the preliminary plans and estimates, that, large as was the section of land appropriated for the new station, it would be quite impossible to accommodate the heavy traffic which would have to be dealt with if the ordinary methods were adopted.

tion with the expedition that would be necessary to enable the trains to keep their schedule time. They accordingly hit upon the bold and original plan of

building a double-deck station, separating the trains broadly into two classes, express and suburban, and handling the former on the upper deck of the station

known Nantasket experiment, now of nearly five years' standing, which has been so far successful as to warrant an extension of the system to some of the other suburban lines. The incorporation of that motive power into the plan of the new station may justly be considered the most decisive advancement that electricity has ever made in steam railroading.

Although at first glance it would hardly seem possible that two looped tracks could take the place of the twenty-eight stub tracks on the main floor above, as a matter of fact the switching problem, which is really the element that determines the capacity of a stub track terminal station, is practically disposed of, and the platforms are made of sufficient length to accommodate at one time several three or four car trains. By using alternate tracks it will be possible to dispatch a train every minute—a head way which would enable upward of two thousand trains to be handled during each working day of eighteen hours on these two tracks alone. This is about five times as many trains as are at present running in suburban service. The suburban tracks enter the station at one side of the steam tracks, and, as they enter, they spread apart, so as to provide a large platform between the tracks. The central platform lies immediately below the midway on the main floor, and it is connected with it and with the main waiting room by stairs. This inner platform is the loading platform, and the unloading will take place on the two outer platforms. The total platform area on this floor will accommodate twenty-five thousand people at one time. As the platform is four feet above the tracks, it will only be thirteen feet by the stairway to the main floor above. Long distance traffic on the main floor is handled upon twenty-eight stub tracks. They are arranged in pairs, with a passenger platform to each pair, and between the pairs are seven platforms devoted exclusively to the trucking of baggage and ex-



**TEST OF PILES—60 TONS OF PIG IRON ON THREE PILES; NO SETTLEMENT.**

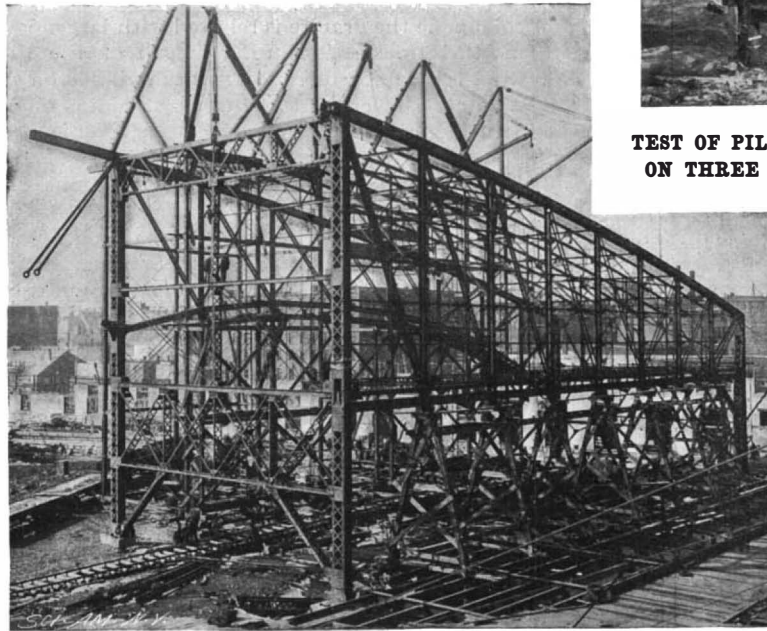

**ERECTING THE OUTER SPANS OF THE 570-FOOT, CANTILEVER, ROOF TRUSSES.**

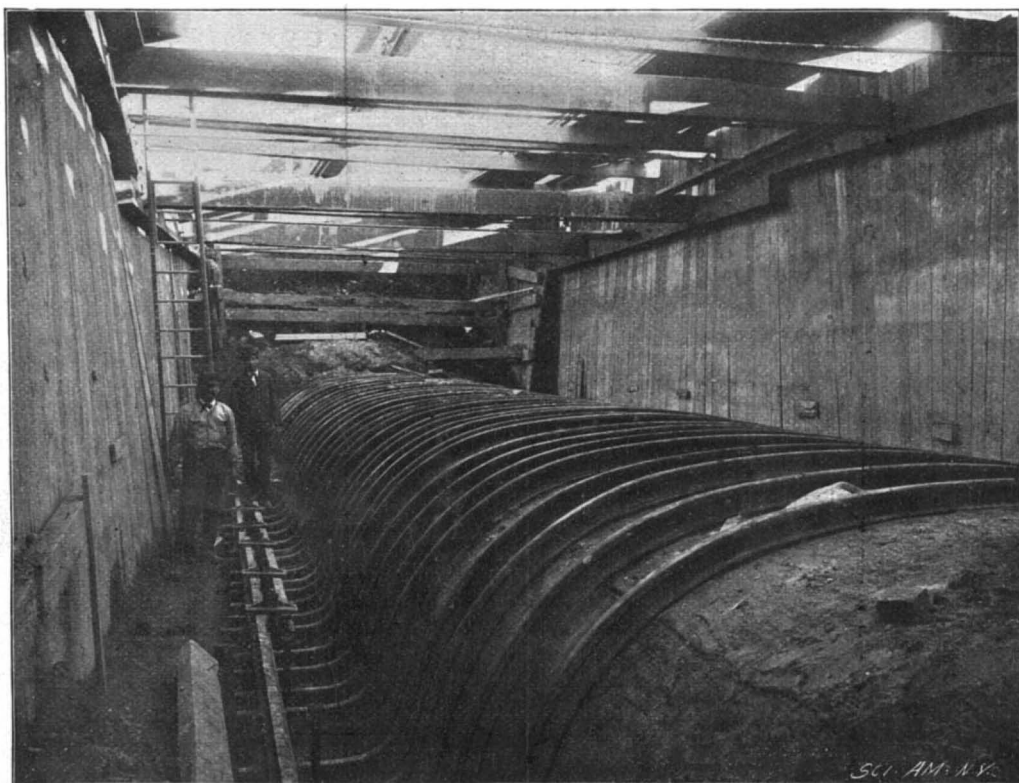

**FLATTENED PORTION OF SEWER BENEATH TRACKS OF BOSTON TERMINAL STATION.**  
This portion of sewer is below high tide level and subject to hydraulic pressure. Hence it is strengthened as shown by straps formed of railroad iron.

press matter. The trainshed, which is 602 feet long by 570 feet wide, is covered by a curved roof supported on huge cantilever trusses, the trusses being supported on two lines of columns which extend down the full length of the station. The extreme height of the trainshed is 112 feet. The middle span is 228 feet wide; the two side spans are 171 feet wide.

In order to exhibit the immensity of the undertaking, the engineers prepared a diagram (see illustration) showing how twenty-four of the prominent buildings of Boston could be founded within the area covered by the main structure. The study of this diagram, which is herewith reproduced, will be of considerable interest to the reader. The total area of the terminal site is about thirty-five acres, and thirteen acres of this is covered by the building itself. The maximum length of the main station is 850 feet; its maximum width, 725 feet; the area of the main station is 506,430 square feet; the area of the awnings outside of the building is 46,000 square feet.

The location of the site is at the confluence of Summer and Federal Streets and Atlantic Avenue, and it lies on the west bank of Fort Point Channel, covering the ground formerly occupied by the New England station. As the ground on which the building stands was originally overflowed by the ocean and was later covered with docks, wharves, and buildings founded on cribs, piles, and rubbish, it can be well understood that an enormous amount of work had to be done in preparing the foundations for such a large and important building. The whole of the structure necessarily stands on piles, of which there were driven about 26,000, and as the lower tracks were designed to lie 17 feet below the main floor and 7 feet below high tide, it was necessary to practically inclose the whole area with a huge cofferdam and introduce some system of waterproofing to keep the lower station dry. A large amount of work had to be done also by the engineers in readjusting the existing sewers, water pipes, and telephone and electric light wires to the new conditions. A continuous watertight cofferdam was driven around the site, at a cost of \$75,000, and a complete permanent waterproofing sheet, consisting of ten layers of tar paper, swabbed together with hot coal-tar pitch, was placed beneath the whole lower floor. This waterproofing, covering upward of ten acres, is laid, where horizontal, upon a smooth concrete base. Where it is on the vertical walls it is backed up with 8 inches of brickwork.

The power plant is contained in a well designed and well lighted building 460 feet long by 40 feet wide, situated on the easterly side of the yard. The total horse power of the plant is at present about 2,000, and room has been provided for an increase of about 50 per cent. It is from this plant that all the light and heat and refrigeration and power are distributed. It contains ten large boilers, two economizers, and 1,500 horse power Westinghouse compound engine direct connected to four Westinghouse multipolar dynamos. The interesting features in the boiler room are the mechanical stokers and the forced draught, the latter being produced by a pair of large slow-running exhaust fans. In addition to providing for the exten-

The main entrance is opposite the end of Federal Street, at the intersection of Summer Street and Atlantic Avenue. The building extends from the entrance south along Atlantic Avenue for 798 feet and east on Summer Street 672 feet. The central portion of the building, as seen from Federal Street, is five stories in height; the first story is given to station uses, and the other four stories are used as offices. The central curved portion is 228 feet in length. Two stories form a strong base in which are three great entrance arches, and the upper three stories are treated as a colonnade, the columns of which are 4½ feet in diameter and 43 feet high. Above the colonnade the entablature and parapet carry the façade to a height of 105 feet above the sidewalk. All the curved portion of the building is of Stony Creek granite and nearly all of the remaining front is of this stone, except that on each side of the

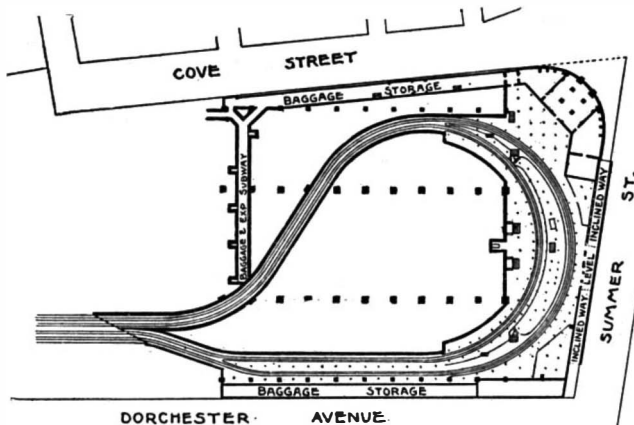

PLAN OF DEPRESSED SUBURBAN TRACKS, BOSTON TERMINAL STATION.

colonnade the granite is relieved with large, dark buff, mottled bricks. The total length of the five-story front is 875 feet; of the two-story building on Atlantic Avenue, 356 feet; of the two-story building on Summer Street, 234 feet, while on Dorchester Avenue the building continues 725 feet; this portion being two stories in height. The total length of the front on three streets is 2,190 feet.

Entering the station by a broad passageway, 92 feet in width, which is lined with polished Stony Creek granite, and has its roof carried on four great columns of polished Milton granite, we reach the "midway," as the space between the waiting rooms and offices and the gates leading to the several tracks is called. On the left are the lavatories, telegraph and telephone offices, ticket office, with eleven sales windows opening toward the midway and sixteen opening on the opposite side into the waiting room. The main waiting room is 65 feet wide by 225 feet long. The floor is of marble mosaic, while the walls have a polished granite base and a high dado of enameled brick. Opening out of one corner of the waiting room is the women's room, 34 x 44 feet. Another notable room is the lunchroom, measuring 67 x 70 feet. The east side of the trainshed is flanked by a room for inward baggage 507 feet long by 26 feet wide. The building above the first story is used for officers and employees. The archi-

of tracks entering the station is thirty-two, and their total length amounts to about fifteen miles, of which four miles is contained under the great trainshed roof. The total weight of rail used is 25,000 tons; there are 37 double slip switches, 252 switches, 233 frogs, 150 semaphore signals, 200 signal lamps and 9 signal bridges. In connection with the station there are 235 arc lights, 6,000 incandescent lights, 25 electric elevators and 215 office rooms.

The materials of construction include 43,000 spruce piles, 16,000,000 bricks, 15,000 tons of steel, 200,000 cubic feet of cut stone, 75,000 barrels of Portland cement and 20,000 barrels of Rosendale cement, 5,000,000 cubic feet of yellow pine timber, 10 acres of gravel roofing, 150,000 square feet of wire glass, and 20,000 tons of putty wherewith to set the same. Finally it should be mentioned that to paint the building required 200 acres of painting estimated as a single coat.

For the particulars and many of the illustrations we are indebted to the courtesy of Mr. George B. Francis, the resident engineer of the Boston Terminal Company.

#### Mortality Statistics of the Prisons During the Civil War.

Surgeon-General C. M. Tebault, of the United Confederate Veterans, issued a circular to the survivors of the medical corps of the army and navy of the Confederate States, calling on them to attend the eighth annual reunion of the United Confederate Veterans, at Atlanta, Ga., which met July 20 to 23. In it he said:

"The destruction by fire of the medical and surgical records of the Confederate States, deposited in the Surgeon-General's office in Richmond, Va., in April, 1865, renders the roster of the medical corps somewhat imperfect, hence the need of concerted action on the part of the survivors to bridge this hiatus. The official list of the paroled officers and men of the Army of Northern Virginia, surrendered by General R. E. Lee, April 9, 1865, furnished 310 surgeons and assistant surgeons. In the first report, presented at the Richmond reunion, I showed that the medical roster for the Army of Tennessee has been preserved in duplicate. I shall offer in a more detailed report data to prove indisputably important facts relating to the prisoners of war upon both sides, with the purpose of establishing the death-rate responsibility in the premises. It will suffice to mention here that the report of Mr. Stanton, as Secretary of War, on the 19th of July, 1866, exhibits the fact that of the Federal prisoners in Confederate hands during the war only 22,570 died; while of the Confederate prisoners in Federal hands 26,436 died. This report does not set forth the exact number of prisoners held by each side respectively. These facts were given more in detail in a subsequent report by Surgeon-General Barnes, of the United States Army. That the whole number of Federal prisoners captured by the Confederates and held in Southern prisons from first to last during the war was in round numbers 270,000, while the whole number of Confederates captured and held in prisons by the Federals was in like round numbers only 220,000. From these two reports it appears that with 50,000 more prisoners in

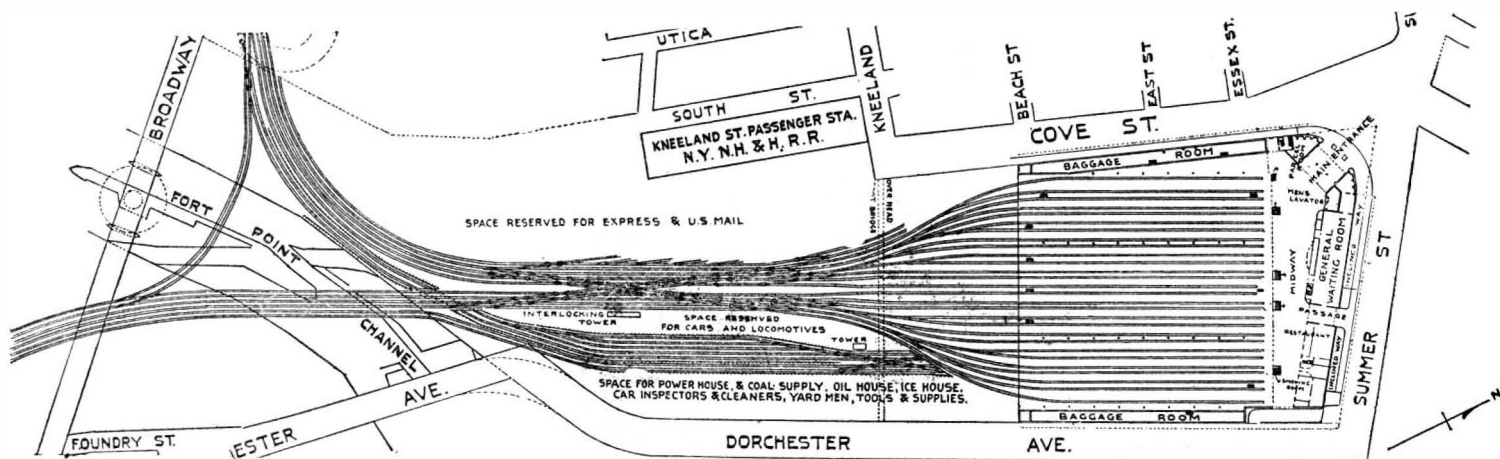

PLAN SHOWING ARRANGEMENT OF TRACKS IN YARD AND SHED OF THE BOSTON TERMINAL STATION.

sive electric arc and incandescent lighting, the electric current is used for operating all the elevators and baggage lifts. There are in all nineteen of these electric elevators, five of which are for passenger service, two for freight, and twelve for the handling of baggage between the upper and lower levels. Provision has also to be made for heating and ventilating the 5,000,000 cubic feet of space included in the headhouse and baggage rooms. This is carried out by several different methods. One of the most interesting features is the ice making and the refrigerating plant, in which twenty tons of diamond ice will be made each day. An extensive system of steam and compressed air piping has been distributed through the yard and trainshed for warming the cars while standing on the track in cold weather and to supply compressed air for the air brakes prior to the departure of the train.

jects of the headhouse are Messrs. Shepley, Rutan & Coolidge.

It should be mentioned that the switching and signaling system, which for a station of this unprecedented size is necessarily very extensive and complex, includes an elaborate installation of Westinghouse electro-pneumatic interlocking apparatus for handling all the trains of the four tenant railroads to and from the main trainshed, and for handling the frequent trains of the suburban service, which are to use the track in the depressed suburban loop. We hope to give full details and illustrations of this plant in a later issue.

In concluding a notice of this, in some respects, the most remarkable building in the world, it will be of interest to give some further statistics of its size and the materials used in its erection. The total number

Southern stockades or other modes of confinement, the deaths were nearly 4,000 less. According to these figures, the percentum of Federal deaths in Southern prisons was under nine; while the percentum of Confederate deaths in Northern prisons was over twelve. These mortuary statistics are of no small weight in determining on which side there was the most neglect, cruelty and inhumanity, proclaiming as they do a loss by death of more than three per cent of Confederates over Federals in prisons, while the Federals had an unstinted command of everything."

BICYCLERS will have a new toe clip which is hinged to the side of the pedal and has extensions on the front and rear which spring the clip into place when touched by the foot, the pedal always being balanced for use either side up.

Correspondence.

Three Eras of Our National Growth.

To the Editor of the SCIENTIFIC AMERICAN :

I renew my subscription again for the SCIENTIFIC AMERICAN. Since I became acquainted with the SCIENTIFIC AMERICAN in its childhood of 1845, we have passed three marked eras national in character, two of which have made an indelible impression upon our people and country.

First—The great gold discoveries in California which gave the first impetus to our railroad building and settling of the great West. (I am an "old forty-niner," and helped to do it.)

Second—The war of 1861-65, which set free 4,000,000 of slaves, and brought about an entirely new order of things in the Southern States.

Third—Last and greatest of all, our almost bloodless war with Spain. Greatest, because it brings the new tenet of humanity, added to the old creeds of Christendom, and will be the brightest jewel in the diadem of American liberty. The two first-mentioned eras have marked unprecedented success in the arts, science, agriculture, and business; but the third, with its world-wide expansion of love and humanity, will excel them all.

When I read of some of our prominent men, political leaders, talking of "imperialism," I hang my head in shame. The word imperialism ought to be eliminated from our American language.

"Then let us pray, that come it may,  
As come it will, for a' that,  
That man to man the world o'er  
Shall brothers be for a' that."

Bedford Springs, Va.

J. R. M.

Type of Coast Steamboats.

To the Editor of the SCIENTIFIC AMERICAN :

The loss of the steamer "Portland" still interests and excites the people of the Eastern States. It also brings up the question of the best type of vessel for the short coast routes. The "Portland" may be taken as a typical ship. She was heavily built, diagonally fastened with iron, and was considered a strong boat. The freeboard was greater than usual. This feature, together with the fact that she had a vertical beam engine and paddlewheels, made her a very easy sea boat. The guards, which are usually dangerous in river boats when they go outside, were in this case sponged out and tightly planked, so that they were not a serious disadvantage to her. They tapered out very quickly forward, so that for a long distance they presented no obstruction to the bow in entering a wave. The houses on the main deck went all the way forward, so that when the gangways were closed the whole vessel was closed to the upper deck.

This type, with slight modifications, has been used on the Eastern coast for fifty years. The fundamental reasons are found in the following facts: These are the easiest sea boats that ever floated. They resist both rolling and pitching in a remarkable way: This is partly due to the position of the machinery and partly to the paddlewheels. The latter greatly steady a vessel, stopping a regular roll even more effectually than a bilge keel. In the second place, carrying the freight on the main deck makes them easy in a heavy sea, while it also makes loading and unloading rapid and inexpensive.

Boats of this class have been exceedingly safe. The loss of one by foundering is almost unheard of. The last case that the writer calls to mind was that of the "Governor." She went down off Cape Hatteras in 1862 or 1863. The gale on that occasion was of phenomenal severity. Such boats make far better weather in a heavy sea than any propeller.

Having just returned from Boston, and having had good facilities for judging of the storm and the wreck, the following facts may prove of interest in forming a conclusion in regard to boats of this class. It will, of course, be borne in mind that they are river boats only in appearance.

The storm itself appears to have been more severe than any which has visited the coast since the first settlers landed. One example of the power of the sea was shown at one place when the keel of a wrecked coal barge was left 50 feet above high water mark and 200 feet inland. Destruction of property along shore was almost beyond account and quite beyond imagination.

What happened to the "Portland" seems to me to have been this: Finding that he could not run away from the gale, i. e., keep ahead of it, the captain put her nose straight into the wind and worked off shore. The boat made as easy weather of it as possible under low steam, barely keeping steerage way. She probably crawled off in this way till well to windward of the cape. Then she got the weight of the sea, and her upper works began to be smashed by the waves. Then commenced the fight for life. As the light houses which form the hurricane deck began to go, the water would go down on the main deck, breaking the freight loose and probably knocking out the sides of the main

house or main deck sides. In a word, the sea battered the vessel to pieces above the main deck and sent such volumes of water below that the pumps could not handle it. In this way, with upper works broken in or washed away, but still "head on," she probably went down, having been gradually drifting to leeward for some hours.

This hypothesis is confirmed by the condition of the wreckage, of the bodies found, and of the freight. The whole cape seems to be covered with the debris of the steamer. But there is nothing except the light upper works and the freight.

The lesson seems to be directed against the very light superstructure which is usually placed above very sturdy hulls. The seagoing qualities cannot be much improved. I mean the behavior in seaway. As freight boats or passenger steamers, they are satisfactory. But to surmount a diagonally fastened wooden hull, or one of iron, with two stories of bandboxes, with only inch siding to keep out the sea, is not quite consistent. The upper works of many of these vessels are also structurally weak. They are not properly supported and tied to the hull itself.

The remedy is simple: Carry the hull to the upper deck; make the upper or saloon deck a structural portion of the hull; build the sponsons and guards in as part of the framing of the hull. Had the "Portland's" hull been thus carried up, she might have lost her pilot house and officers' rooms, and even the saloon and staterooms, but she would have come into port with her cargo and probably all her passengers.

Philadelphia, Pa., January 2, 1899.

E. F. C.

A New Plan of Education.

To the Editor of the SCIENTIFIC AMERICAN :

Few people, if any, have not experienced the trouble of receiving correct and speedy information, when the business or pleasures of their everyday life demanded a knowledge of some fact or other not connected with their immediate surroundings.

What is the price of such or such an article in Paris? Where can I get the latest statistics of the American lumber trade? What is the cost of life in Cairo or Norway? How many days do I need for a trip to Moscow? Which is the cheapest technical school in Germany, and where can I get all the particulars about it? Hundreds of such questions must have occurred in every one's life, and when it was indispensable to get an answer, we all know what a bother and often what an expense it was to get it. If such troubles often beset an inhabitant of such great centers of intelligence as London, Paris, or New York, how vastly are they multiplied in the case of a resident in the country or in some far-off colonial settlement! The difficulties are then usually so great as to be quite insuperable, and the seeker for information has to put up with this unpleasant discovery.

We think the time has come to put an end to this state of things, and also that there is a simple and easy way of doing so.

Suppose you were offered the privilege of having your own "special correspondents" in all parts of the world, who would undertake to give you correct information on every possible topic, at the cost of a prepaid postal card, on the sole condition that you would also consent to answer such questions on subjects indicated by yourself, and costing you neither trouble nor expense—would you refuse that privilege? The question seems hardly worth putting!

Let us now try and explain how that can be done. Imagine to yourself a central committee or bureau, situated in one of the central cities of Europe, say Geneva. This bureau elaborates and circulates in all the cities of Europe, America, and the colonies a systematically arranged programme of useful information and a general invitation to all who would like to become members of the "International Association for Mutual Information" to send their names and address to the central bureau, stating the language (preferably English, French, or German) in which they could correspond and the topics (general or special, universal or local) on which they were ready to give useful information. On receipt of the answers to its circular, the bureau would then compile a series of lists, one for each department of its programme, containing the names and addresses of all the correspondents willing to reply to questions on the subjects of such a department, together with the necessary indications as to the scope of their information, the languages they used, etc. These lists printed, the bureau would then forward them to all its correspondents, in accordance with their demands. (We presume that nobody would demand the lists of correspondents on subjects of no possible interest to him; the more so, that in case of an unforeseen necessity for such information, a simple note to the bureau would immediately bring the required supplementary list.)

From the day that the members of such an association received their lists, they could enter into direct relations with their correspondents all over the world, taking care only to prepay the expected answers. It is self-evident that no sense of personal obligation would trammel such a correspondence, for every one would

remember his readiness to render the same service to other correspondents.

Henceforward, the business of the central bureau would consist in the annual or semi-annual revision and correction of the lists, in attending to the wants of members, in managing the general business of the association, and in organizing local offices and agencies in all countries. These local agencies would assist the central bureau in its general work, serve as interpreter between members writing different languages, publish periodical papers of general information for the benefit of the association etc.

Wishing to state our plan as briefly as possible, we shall not pause to describe in detail our ideas of the way in which these offices should be organized, of the rules which members of the society should observe; neither shall we consider here the probable developments of this scheme, should it meet with general acceptance; many of these developments will easily suggest themselves to the majority of our readers.

We cannot refrain, however, from indicating one of the immediate consequences of such an association, because of its extraordinary practical value. Consider the case of travelers for business, health, or pleasure: in every town all over the world they can expect advice and assistance from resident members of their own association; nowhere will they feel themselves complete strangers; a card, signed by the central bureau and bearing the owner's name and number, would thus become an introduction to friends all over the world. The inestimable value of such a result should alone suffice to induce all thoughtful men to join the proposed association, letting alone the loftier consideration of international peace and good-will that nothing can promote to such a degree as mutual assistance and friendliness.

A few words now about the means necessary to meet the working expenses. We believe that all the expenses of printing and distributing the programmes, circulars and lists of the association can be easily covered by fixing a certain price on these lists. The price may be exceedingly moderate, considering the vast number of copies, and yet be quite sufficient. A small sum—say one shilling—might also be demanded as an entrance fee to the association, in exchange for a card of membership under the sign and seal of the central bureau. A very considerable fund for working expenses can be collected by issuing special post cards with prepaid blanks for answers, at a price barely exceeding the value of postage. Advertisements in the society's periodicals would surely also become an important source of revenue.

The programme of information that we mentioned as the first work of the central office should embrace all the departments of human knowledge and business. Perhaps the following headings may serve to illustrate our meaning more clearly, not that we ourselves consider such a plan even approximately sufficient. 1. Religion, philosophy, ethics. 2. Education—physical, mental, and moral. 3. Science: (a) Sociology, ethnology, philology; (b) Biology, physiology, psychology; (c) History, archeology, paleontology; (d) Geology, paleontology, etc., etc. 4. Art and artistic industries. 5. Literature, books, and the periodical press. 6. Government and its branches. 7. Law and the courts of justice. 8. Finance. 9. Agriculture and its branches. 10. Technology. 11. Manufacture. 12. Mining. 13. Engineering and machinery. 14. Commerce. 15. Traffic. 16. Travel. 17. Colonization. 18. Correspondence (post, telegraph, etc.) 19. Housekeeping. 20. Hunting, fishing, and sports generally. 21. General information for subjects not otherwise specified.

To conclude. If the readers of this new proposal have anything to say against the desirability or practical possibility of the scheme, we shall be glad to give their opinions our most earnest attention. We think the plan too interesting to wreck it at the outset by any haste or mismanagement.

If, on the contrary, the scheme, as here outlined, should meet with a general approval, we shall apply all our energies to promote its universal acceptance and speedy practical fulfillment. Every one will perceive that this is a matter of public interest, and that its future depends entirely on public opinion. All remarks and letters can be addressed to the undersigned.

N. A. SHISHKOV.

Simbirsk, Russia.

An interesting German invention provides for instantaneous soda water in siphons. The device is called "sodor." It consists of a siphon provided with a wicker covering. The top is of peculiar construction and admits of the insertion of a pear-shaped, thin iron capsule, filled with liquid carbon dioxide gas. The top of the siphon is hinged, and after it is swung into place a lever is pushed down which forces a piercing pin through the "sodor" capsule. The gas then forces its way out through special channels into the top of the siphon and impregnates the water in the siphon. The thick walls of the bottle are not readily broken by the pressure of the gas. This device will undoubtedly prove of considerable interest to those who live at a distance from bottling establishments.

**THE BIOGRAPH IN THE VATICAN.**

Upon the announcement of the recent illness of Pope Leo XIII., it was found that with one exception no authentic photograph of the Pope had been taken during the past six years. Within a few months

in the United States, and by special permission of the Pope he secured nine series for the "Biograph" and "Mutoscope," and these scenes were exhibited on December 14, at Carnegie Music Hall, New York city, in the presence of Archbishop Corrigan and other

can Mutoscope Company, we are enabled to show a view of the Pope seated upon a rustic bench bestowing his benediction while he was being photographed by the Biograph camera. The views certainly bring us into a more intimate relation with one of the great

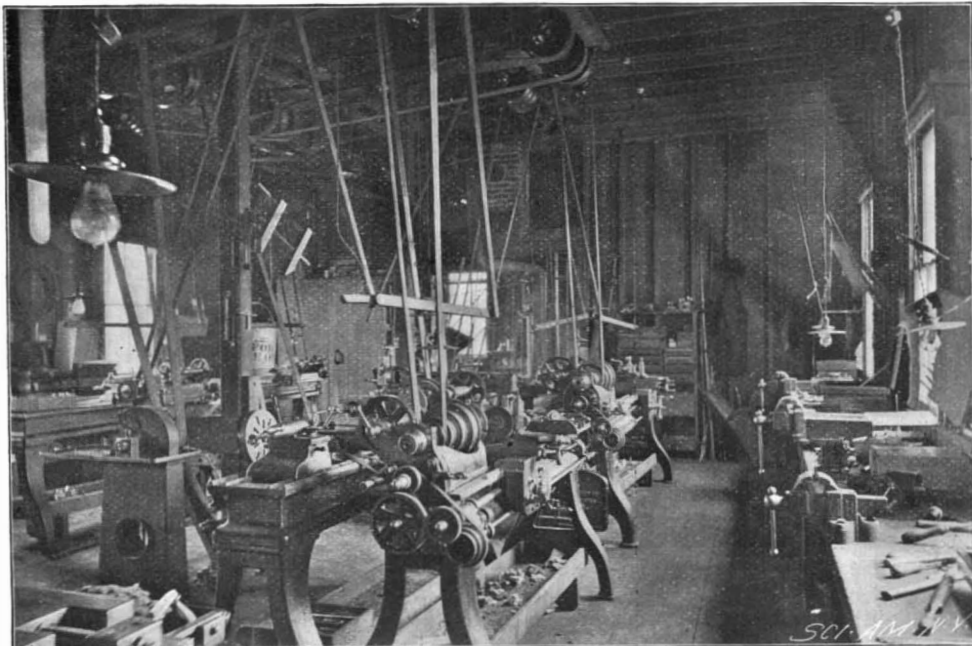

VIEW IN LABORATORY OF INTERNATIONAL MUTOSCOPE AND BIOGRAPH SYNDICATE.

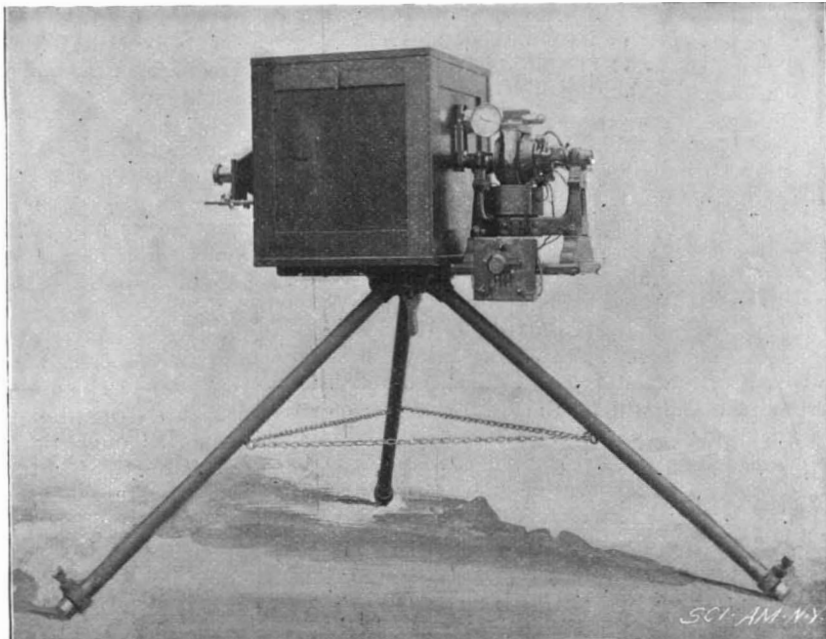

THE PERFECTED MUTOGRAPH, OR BIOGRAPH CAMERA.

however no less than 17,000 photographs of the Pope have been taken with his sanction. These photographs were taken in the loggia and gardens of the Vatican with the aid of the "Biograph" camera.

Mr. William Kennedy-Laurie Dickson, representing the Mutoscope and Biograph Syndicate, Limited, of London, England, the English connection of the American Mutoscope Company, went to Rome for the purpose of obtaining moving photographs of the Pope. He had credentials from Cardinal Gibbons, Monsignor Martinelli, Archbishop Ireland, and other noted prelates

distinguished clergymen of the Roman Catholic faith. They had previously been shown to Monsignor Martinelli in Washington and given his approval.

The moving views show the Holy Father walking and riding in his carriage and sedan chair about the halls and gardens of the Vatican, and in some of these scenes the Pope is seen bestowing his blessing upon the bystanders. He is also seen walking about the garden and sitting on a rustic bench surrounded by some of the chief members of his official household and the Garde Nobili. Through the courtesy of the Ameri-

figures of the closing years of the nineteenth century. When Mr. Dickson was taking the photographs, the Pope asked for an explanation of the apparatus. A copy of the SCIENTIFIC AMERICAN containing an article on the American Mutoscope and Biograph, published in our issue of April 17, 1897, was shown him. His Holiness became much interested in the paper.

The laboratory of the International Mutoscope and Biograph Syndicate, where all of the moving picture apparatus is developed and prepared for the market, is at Canastota, New York. At this laboratory there

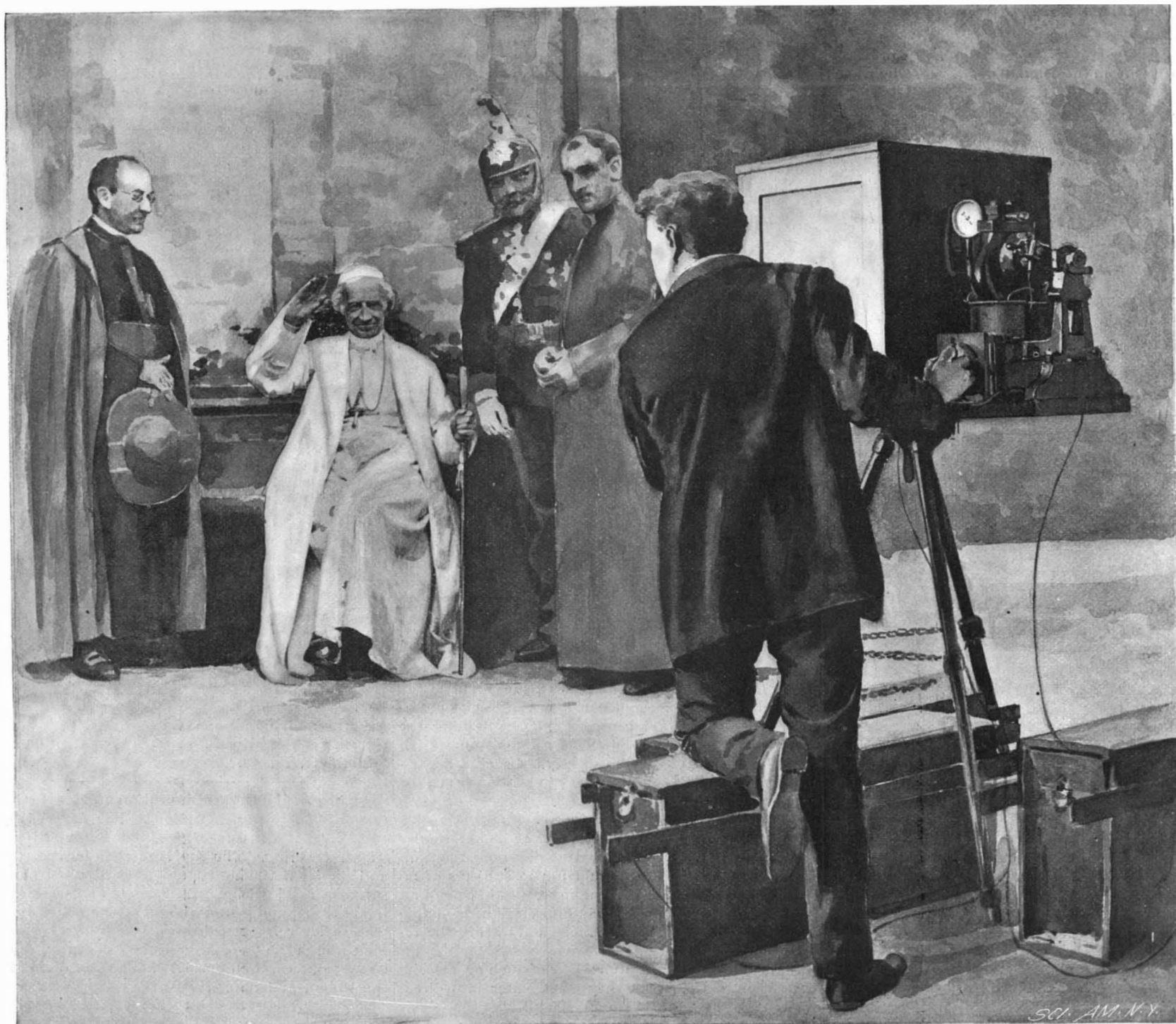

Copyrighted, 1898, by American Mutoscope Company.

PHOTOGRAPHING HIS HOLINESS POPE LEO XIII. IN THE GARDENS OF THE VATICAN WITH THE BIOGRAPH CAMERA.



are employed a large force of inventors and mechanical experts under the direction of Messrs. Marvin and Casler, and constant efforts are being made to develop new and improved forms of moving picture apparatus and to discover new methods of taking and exhibiting moving picture views. All the intricate and special machinery involved in the process of reproducing these views with marvelous exactness is designed and built at this laboratory, and this work requires great mechanical skill and the most perfect tools and appliances known to the mechanical art. The accuracy of this class of apparatus will be better appreciated when one considers

the enormous magnification at which these views are projected upon the screen and the rapidity with which successive views must follow each other in perfect registration. Imagine a sequence of two thousand pictures, each two inches by two and a half inches in size, following each other in turn through the projecting lantern of the biograph every minute, each picture being magnified on the screen to a size of twenty by twenty-five feet, and think how perfect must be the registration of each succeeding picture, in order that the result of the image upon the screen may not appear to dance about and vibrate, but may appear as one continuous set picture! Not only is precision in projecting required, but also in the printing of the positives from the original negative. The negative prints taken by the original camera do not always

follow each other at equal distances upon the strip of film; consequently, in printing the positives the printing machine must be able to correct this imperfect spacing and produce a band of positive prints printed perfectly equidistant. The printing machine must

liar, since it is the workshop for busy brains throughout England and the Continent.

**GUNBOATS AND RAILWAYS IN THE SOUDAN CAMPAIGN.**

It is a fact which is pretty well understood that the remarkable success of the recent campaign under General Kitchener in the Soudan was largely due to the excellent judgment and forethought shown in carrying out what might be called the engineering features of the expedition. The distinguished soldier who more than anyone else was responsible for the planning and execution of the campaign, combined the training and experience of the engineer

and the soldier in one, having been, we believe, in the earlier stages of his military career in the Royal Engineers. As distinguished from the unsatisfactory and barren expedition under Lord Wolseley in the previous decade, the present expedition undoubtedly owes its success to the completeness with which the whole problem was thought out, and the deliberation and accuracy with which each step of the advance up the Nile was made and each important position occupied and strengthened as a base from which to execute the next forward movement. Undoubtedly the most vital elements to the success of the British advance were the military railroads which were constructed through the deserts and the fleet of specially designed gunboats which operated in the upper reaches of the River Nile. The railroads were built largely for the purpose of convey-

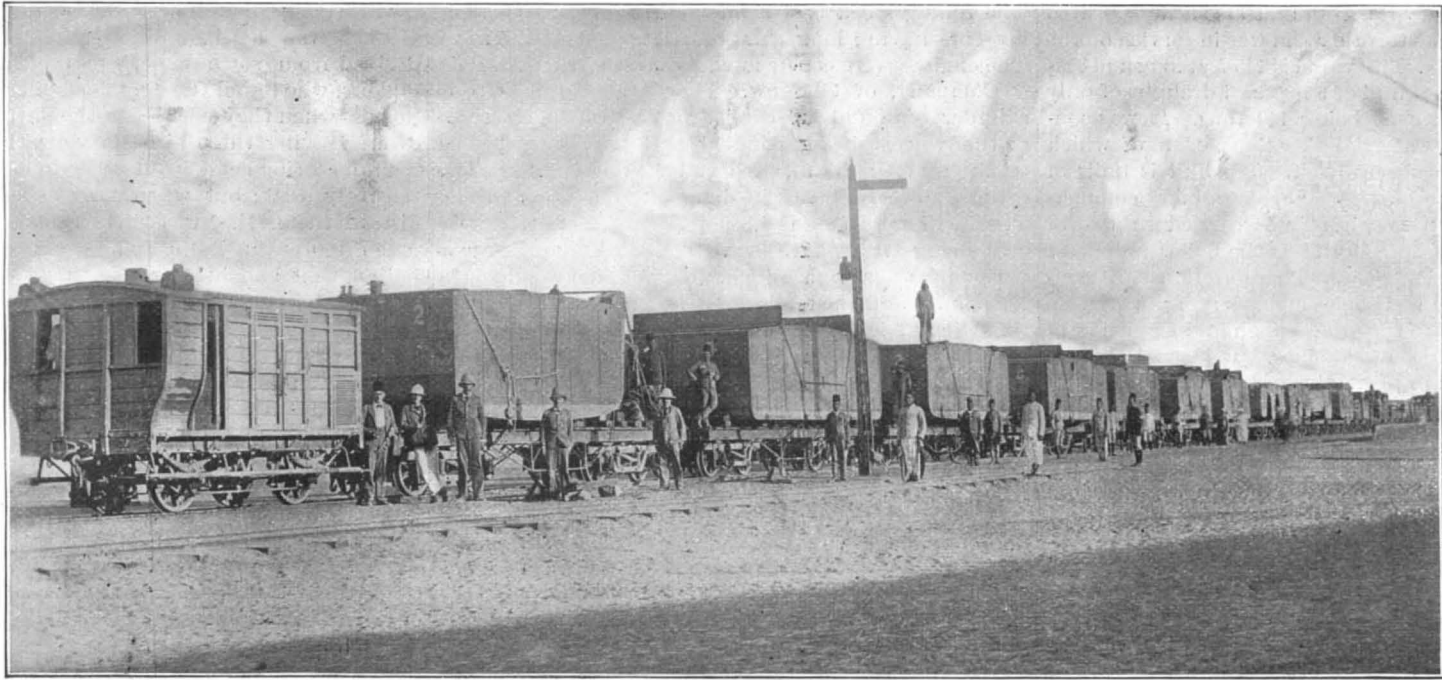

**NILE GUNBOAT "MELIK" BEING CONVEYED BY RAIL, IN SECTIONS, ACROSS THE DESERT.**

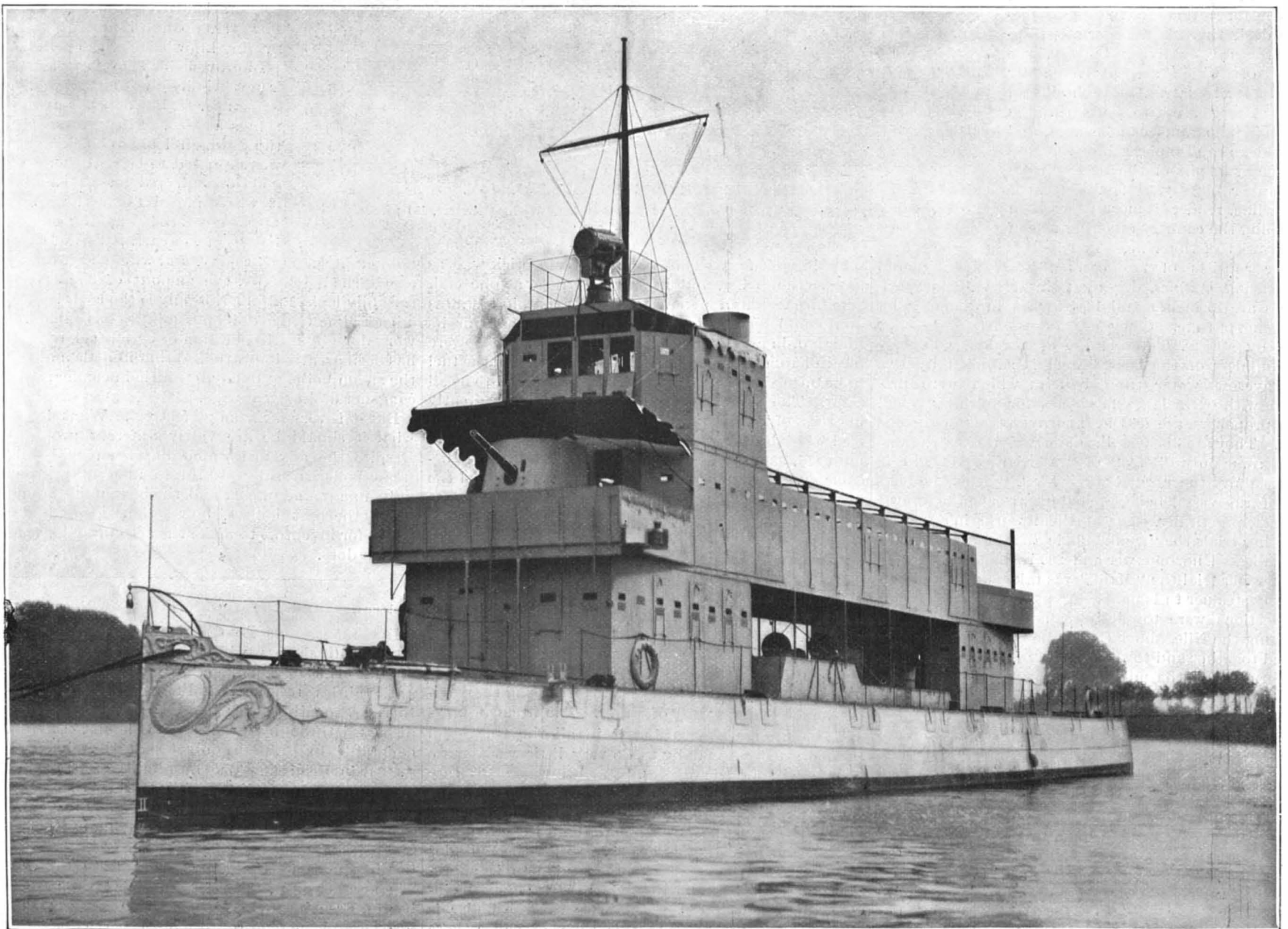

**LIGHT-DRAUGHT THORNYCROFT GUNBOAT "MELIK" USED IN THE SOUDAN CAMPAIGN.**

Length, 145 feet. Beam, 34½ feet. Draught, 2 feet. Speed, 12 knots. Protection: Chrome-steel plating. Armament: Two 3-inch 12-pounder rapid-fire guns; eight 0.45 Maxims; 110 loop-holes for rifle-fire.

ing the gunboats around the impassable rapids of the river to a point at which they might be floated and proceed under their own steam up to the objective points off Khartoum and Omdurman.

In the accompanying illustration we show one of these gunboats, the "Melik," in course of transportation over the military railroad, and also as it appeared after it had been put together and was in service on the Nile above Dongola. The vessel is 145 feet long and 34½ feet wide, with a depth of hull of 6 feet and draught of only 2 feet, the displacement being 140 tons. It was constructed in eleven watertight sections, each of which was capable of floating by itself. The hull is built of two materials—chrome steel and the ordinary commercial mild steel. The machinery is carried in two of these compartments, one forming the boiler room and the other the engine room. These sections are constructed of ¾ inch chrome steel, having a tensile strength of 95 tons to the square inch and extension of 5 per cent on a length of 2 inches. Thin as they are, these plates equal in protective quality ½ inch of ordinary mild steel and they will stop a bullet fired point blank at twenty paces. The use of this material, which of course secures its great hardness at the expense of the toughness and ductility which characterize ordinary steel, provides a remarkably light, bullet-proof construction, and Sir William White deserves every credit for the success of a suggestion which is original, we believe, with him.

The superstructure consists of two deck-houses built of chrome steel, ½ of an inch in thickness. They will resist bullets at a distance of twenty-two yards when striking at an angle of 60°. These two houses are loopholed for musketry fire and they are connected by a bridge deck with chrome-steel bulwarks, above which are movable protective shields, loopholed for small-arm fire. The deck of this bridge is 13 feet wide by 79 feet long. Here the crew are berthed, underneath an awning, and it should be mentioned that the officers are quartered in the forward deck-house below and the engineers in the after deck-house. At each end of the bridge deck are two 3-inch 12-pounder rapid-firing guns, which are protected by shields and carried upon an extension of the bridge deck beyond the deck-houses. Upon this deck amidships there are also two 0.45 inch Maxim automatic guns on each broadside, or four in all. At the forward end of the superstructure deck there is another raised superstructure or flying battery, the sides of which are protected by chrome-steel plate. On each side of this battery are two ports through which Maxim guns can be fired, and the sides are also pierced for rifle fire. The great height of the firing line of the upper battery, 21 feet above the water line, renders it most effective in sweeping the country on either side of the banks of the Nile. The motive

power consists of two pairs of vertical compound condensing engines, driving twin screws. The cylinders are 12 inches and 19½ inches in diameter by 11 inches stroke. They are of the standard type used by Messrs. Thornycroft, of London, who were the builders of the boat. Steel is supplied by two Thornycroft water tube boilers, which were provided with extra large fire-boxes for burning wood. The propellers are of the Thornycroft screw-turbine type. They are 3½ feet in diameter, and, as the vessel draws only 2 feet of water, they extend 18 inches above the normal water level, the bottom plating of the vessel being arched over above the screws, so that, practically, each of them works in a tunnel.

On her trials the "Melik" made about 12 knots, with 460 indicated horse power and 280 revolutions.

After her trial the "Melik" was taken apart and carried by steamer to Ismailia, Egypt. From that point the sections were towed by canal to the Nile. On reaching the Nile, above Cairo, the vessel was roughly bolted together and towed to Wady Halfa, the northern terminus of the military railroad. Here the sections were unbolted and transferred to flat cars, and the whole train, carrying the hull with its machinery, armament, and fittings, was drawn to a point on the Upper Nile above the cataracts, where the vessel was finally riveted together and proceeded under her own steam to Khartoum.

In company with the other gunboats which took part in the battle of Omdurman, this unique vessel did excellent service by directing a heavy fire upon the Dervishes who had passed between MacDonal's division and the river and were endeavoring to surround it. The diversion they created was of great service at that critical moment and greatly assisted in determining the fortunes of the day.

The Sudan military railway, extending from Wady Halfa to Dongola, a distance of about 200 miles, and

from Wady Halfa to Khartoum, a distance of about 600 miles, is of 3 feet 6 inches gage. It was constructed with great rapidity; in some stretches of the road as much as 2 miles of track per day being laid down. The rails weighed 50 pounds to the yard. They are of the American T-pattern, bolted directly to the ties. The rolling stock is of a modified American type, the flat cars having long trussed bodies and end trucks. The engines were constructed by Messrs. Neilson, Reid & Company, of Glasgow. They are of the outside cylinder type and are carried on twelve wheels, eight of the wheels being coupled and the four-wheeled truck carrying the forward end of the engine. The cylinders are 17 inches in diameter by 23-inch stroke. The heating surface is 1,095½ square feet, the grate area being 17½ square feet. The working pressure is 160 pounds per square inch. The engine weighs 104,384 pounds and the tender 75,936 pounds.

Particular interest attaches to this railroad from the fact that it will probably form a portion of the great all-rail route from Cairo to Cape Town, which is destined to be constructed before the twentieth century is many years old.

#### Evaporation of Modern Steam Boilers.

BY EGBERT P. WATSON.

It has been remarked that, while the steam engine has been greatly improved in the past fifty years, the boiler has remained nearly stationary, and that the evaporation has not materially improved. This is erroneous; there has been a great change for the better.

Fifty years ago the boiler in general use was the cylinder boiler, which, as its name implies, was a mere tube of varying lengths, seldom less than 20 feet, and

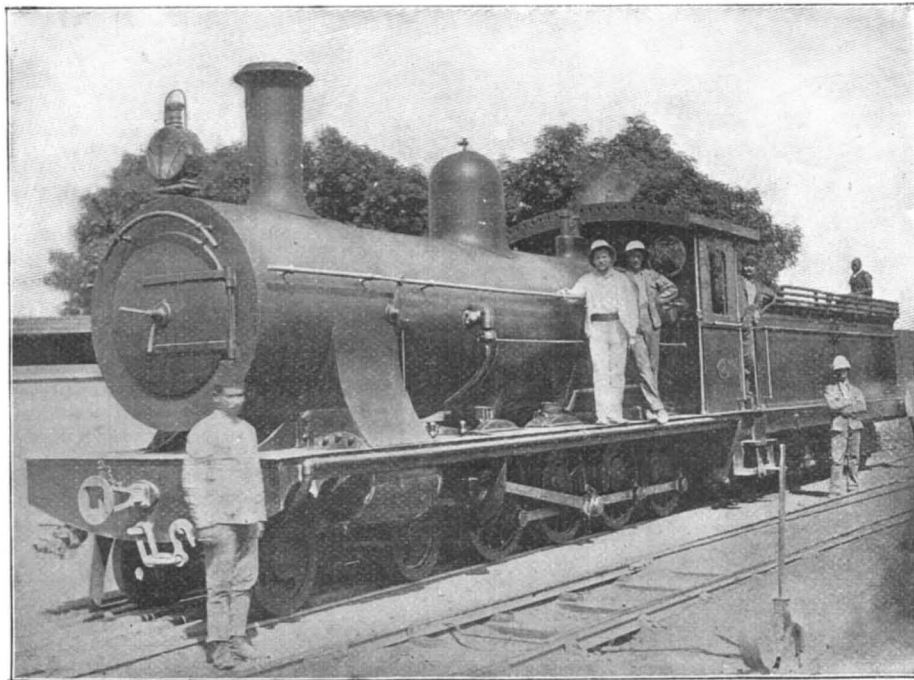

LOCOMOTIVE FOR THE SOUDAN RAILWAY.

Cylinders, 17 by 23 inches. Heating surface, 1,095½ square feet. Working pressure, 160 pounds. Weight, 104,384 pounds.

sometimes 40 feet. This was set over a brick wall as long as the boiler, and having a furnace at one end. The furnace was a mere fireplace; for that, in fact, was all it could be called. It was much too small for its function, in a majority of cases, and the grates were put in haphazard. So long as they would hold the fuel to be burned upon them, they were considered to be all right. The amount of air they admitted was greatly in excess of that required for proper combustion, and feed water heaters were unknown. Bridge walls were not used, as a rule, but, when coal was burned, it became necessary to have some obstacle at the end of the furnace to prevent it from being thrown over the grate into the space beyond it. The writer distinctly remembers opening the furnace doors of old time cylinder boilers and seeing nothing at the end of the furnace but a vast cavern which yawned the whole length of the boiler proper. In a few words, the old cylinder boiler was a mere tubular pot beneath which a fire was kindled. Where wood was plentiful and coal was dear, the former was used in four-foot lengths; and, from the fact that it made a great blaze, and looked as though it made a hot fire, it was supposed to be causing the evaporation of a great deal of water. The firemen, however, had to keep throwing it in all the time, and burned many cords daily to do very little work, as we now understand the subject.

With no circulation whatever, and the effective fire surface only a narrow zone, or comparatively small area of the actual surface exposed (half the circumferential length), it is not surprising that the cylinder boiler did very little work in proportion to its superficial area and its weight, in which latter must be included the weight of the setting, since the boiler is inoperative without it. In this type of boiler there was a vast difference between the temperatures of the front and back ends, particularly as the latter was occasionally stuck through the building for want of room

inside. The average evaporation was not over four pounds of water per pound of fuel burned with natural draught, although it must be admitted that owing to the fact that fifty years ago no one paid much attention to this aspect of steam using, it is very difficult now to find authentic logs of actual performance. If there are any records, they have not been made public, to the writer's knowledge, and the statement made above is derived from some experiences of a firm of boiler makers, who found the cylinder boiler a formidable opponent when they undertook the introduction of their own. Having this object in view, they visited large manufacturing centers where cylinder boilers were extensively used; but when they asked steam users to discard them, the water tube men were considered much too enthusiastic. The idea of throwing out boilers that had been in use thirty years, and looked as though they would last thirty more, to install a "new-fangled" evaporator in their place, was not to be entertained for a moment, and some of these conservative men are still holding on to their old cylinder boilers.

Although modern boilers are a great advance upon the crude evaporator of fifty years ago, the changes made have been gradual. Engineers, seeing the sluggish action of the cylinder boiler, put in two flues running the entire length of it; and finding that no disasters occurred, as had been predicted by some timid souls, they went further and made the tubulous boiler, or return tube boiler, which is to-day in general use. It is a boiler which is easy to make and is cheap, for the reason that it is all machine work, but it requires a more or less cumbrous brick setting, so the ultimate cost is but a little less, if any, than other types. Return tubular boilers when properly set and carefully managed will show excellent evaporative efficiency; nine and ten pounds of water per pound of coal is not unusual, although this is higher than the average rate. Add to this that repairs are light if oil is kept out of the boiler and we have cogent reasons for its popularity.

In well-managed plants, where skilled engineers are employed, the average evaporation is more than double what it was fifty years ago; but in other places, where the boilers are foul with scale, where the air leaks badly through the brickwork, where the boilers are looked after only semi-occasionally by youths or laborers, the evaporation is very low. Such places, however, do not represent the engineering knowledge of the period.

Improved efficiency in steam boilers is not wholly due to improvements in boilers per se, but depends upon other things as well. Fifty years ago anything which looked black and hard was supposed to be coal, at all events good enough coal for a steam boiler; it was dumped upon the consumer pretty much as it was dug out of the bowels of the earth. Steam users will

not accept such fuel to-day, and where large quantities are burned annually, the amount of combustible is carefully looked after. Not only is the coal cleaner, but a better knowledge of its possibilities has enhanced the work done by it. In addition to better fuel, the furnace has been greatly improved, so that in little and in gross the steam boiler of to-day has little in common with its congener of fifty years ago.

But it is very far from perfect yet. What it is and what it should be are vastly different propositions. Despite the advance which has been achieved, the steam boiler is still wasteful in many ways, the heat units in a pound of coal and the heat units accounted for by the best boilers show serious losses, and it remains for inventors to make the account balance closer than it does.

#### France and the Immigration of Foreigners.

In France, says Le Chasseur Français, there are 1,130,241 foreigners, while in foreign countries there are but 517,000 Frenchmen. The Europeans of various nationalities residing in France number 1,112,072; there are, on the other hand, but 217,000 Frenchmen dispersed through Europe. Of Belgians, 465,870 have emigrated to France; only 52,000 Frenchmen have settled in Belgium. The hospitality of France is accorded to 286,042 Italians, while in Italy there are only 11,000 Frenchmen. Of Germans there are in France 83,333; the number of Frenchmen living in Germany is 24,000. France has within its borders 14,337 Russians; but in Russia itself there are but 5,200 Frenchmen. The number of Austrians in France is 12,000; the number of Frenchmen in Austria, 3,000. For Spain and Switzerland the figures are more nearly equal. There are 77,000 Spaniards in France and 25,000 Frenchmen in Spain; 83,117 Swiss in France and 54,000 Frenchmen in Switzerland.

**DAMAGE BY SPANISH SHELLS ON THE CRUISER "BROOKLYN."**

Whatever may be said about Admiral Schley as a tactician, there is one significant fact in the naval campaign in the West Indies which his detractors would do well to keep in mind, a fact of a kind which is popularly supposed to bring more glory to him whom it concerns than do any other of the happenings of battle.

Admiral Schley's ship, the "Brooklyn," came out of the campaign carrying more of the scars of battle than were left by the war upon any other ship in the whole American navy. After the Santiago fight she showed more shot holes than the "Oregon," "Indiana," "Iowa," "Texas," "Gloucester," and "New York" combined, and in the number of separate hits recorded she was exceeded by only one of the Spanish cruisers, the "Almirante Oquendo."

When the Spanish fleet left the harbor and turned to the westward, the "Brooklyn" was the only ship that stood directly in their way, and, in accordance with a prearranged plan, the fire of the Spaniards was concentrated upon her in the hope of "winging" our fastest vessel, and so enabling the fleet to escape. She was thus exposed to the united attack of the Spanish ships at the only period of the fight when they seemed to have had the range of our vessels; that is to say, during the first exchange of shots. For it is a curious and very significant fact that when our men went aboard the Spanish cruisers after the surrender the sights on their guns were found to be still set at the 4,000 to 5,000 yards range at which the enemy opened fire. It is evident that the excitable Spanish gunners completely lost their heads, and failed to make the necessary changes in the sights as the ships closed in on each other.

This error on the part of the gunners, coupled with their own statement that the "Brooklyn" was the object of their first and concentrated attack, goes far to explain the severe punishment of this vessel compared with the comparative immunity of the other ships of our fleet. When Schley saw the "Vizcaya" alter her course so as to head directly for his ship, he naturally supposed that it was the intention of the Spaniards to close in and sink him with the rana (a matter easy of accomplishment where it is a case of four vessels against one), and with excellent judgment he swung his vessel to starboard, making a complete half turn, and took up a position for a running fight down the coast with the flying Spanish vessels.

Now, if the reader who is interested in the subject will turn to a table published in our issue of September 10, in which we analyzed the gun fire of our ships at Santiago, he will find that in the larger rapid-fire calibers the greatest number of hits was made by the 5-inch gun, the "Teresa" being hit by 3, the "Oquendo" by 3, the "Colon" by 2, and the "Vizcaya" by 7 5-inch shells. As the "Brooklyn" was the only ship that carried this caliber, these hits must have been made by her gunners.

This, then, is the record of Admiral Schley's ship in that four hour engagement: She was the first under fire, she was the leading ship in the chase, she made the best practice with her guns, and she carried more of the honorable scars of battle out of the fight than were to be found on all the other ships of the squadron combined.

We think that the gallant admiral may well rest on his laurels as a fighter, and treat the criticisms of his tactics with the dignified silence which has characterized his bearing throughout the war.

The accompanying illustration of a group of mutilated plates that were cut out of the ship at the Brooklyn navy yard speaks for itself. Some of the holes were made by the shells themselves at the point where they first struck the ship and others were made by the flying fragments after the shells exploded. The general testimony of our officers is that the Spanish shells burst with great efficiency, flying into numerous frag-

ments, each of which cut its way destructively through the partitions, bulkheads, etc., of our ships. Our own shells, owing to the excellent quality of the steel, did not burst effectively, that is to say, the steel was too strong for the powder to fracture it into small pieces. This will be remedied in the future.

The fragments numbered 11, 15, 16, 18, 19, and 20 were taken out of the smokestack casing on the berth deck. This casing is built of 1/4-inch steel and extends from the protective to the berth deck. In the event of the protective deck being flooded, it would prevent the water from flowing down into the boiler room. The holes were made by the fragments of a 4'7" or a 6-inch shell which passed through the side of the ship and burst on the slope of the protective deck, the fragments

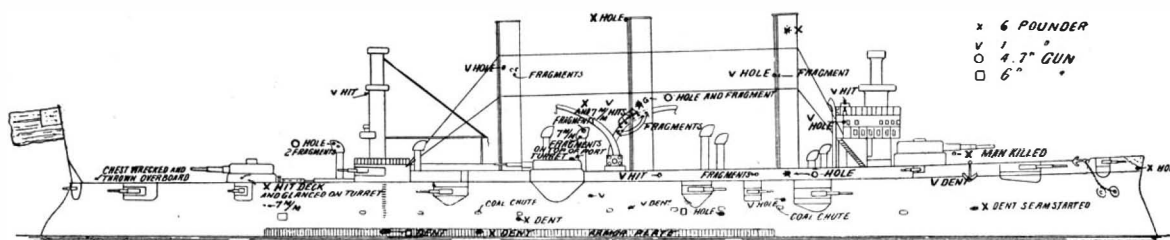

**DIAGRAM SHOWING LOCATION AND NUMBER OF HITS RECEIVED BY THE "BROOKLYN" IN THE SANTIAGO ENGAGEMENT.**

being deflected upward and tearing their way through the casing.

No. 12 is a portion of an engine room ventilator which stood on the quarter deck. No. 14 shows the effect of a little 6-pounder shell which struck and passed through the 3/8-inch plates of the hammock netting. No. 17 is a portion of one of the beams of the berth deck on the

**The Vatican.**  
The assemblage of buildings called by the name of "The Vatican," and which extends in an oblong, irregular mass north of St. Peter's as far as the town walls, consists mainly of (1) the Papal palace, (2) the court and garden of Belvedere, (3) the Library, (4) the Museum. The Papal palace contains, among other remarkable objects, the Sistine and Pauline chapels, painted by Michelangelo. The Sistine Chapel contains the painting of the "Last Judgment;" the four "stanze," or apartments, painted by Raphael; and the "logge," or open galleries, painted by Raphael's pupils under his direction. There are numerous other apartments, with paintings and other objects worthy of notice, which are described in the guide-

books. The principal stair case, made by Bernini, is a splendid work of art. The Vatican is said to contain altogether eight great staircases, more than twenty courts, twelve great halls, and several thousand apartments large and small. A corridor, about 1,000 feet long, joins the Papal palace to the building called "Belvedere," which serves as a museum.

About half way up this corridor is the entrance to the Vatican library, which was built by the architect Fontana, under Sixtus V. Pope Nicholas V. was the founder of the Vatican library, which has been increased by many popes. The libraries of the Duke of Urbino, of the Elector Palatine, of Christina of Sweden, of the family Ottoboni, and others, have been added to it. It contains 80,000 printed volumes and 24,000 MSS., of which 5,000 are in Greek, 16,000 in Latin, and 3,000 in the Oriental languages. Partial catalogues of this great store of learning have been published by Asemanni, Marini, Mai, and other librarians. The museum or collection of works of art, mostly of ancient sculpture, was begun by Clement XIII. and Clement XIV., and greatly increased by Pius VI., who was a man of taste, and who gave it the name of "Museo Pio Clementino." It was illustrated by Gio. Batta Visconti and his son, Ennio L. Visconti, in seven volumes folio, with plates, Rome, 1782. Pius VII., during his troubled pontificate, began a new collection, to which has been given the name of "Museo Chiaramonti." The two together, which are distributed along the court, garden and palace of Belvedere, constitute the richest museum in Europe. Another and more extensive garden belonging to the Pope is annexed to the Vatican palace, and extends along the brow of the hill.—The Architect.

**The Current Supplement.**

The current SUPPLEMENT contains many articles of more than usual interest. "A Design for an Electric Launch Motor," by C. T. Child, is an important paper, accompanied by nineteen illustrations and working drawings. With the aid of these working drawings any mechanic can make and fit up an electric motor for a launch. "The Tactical Applicability of the Maxim Machine Gun" is an interesting and important paper by Lieut.-Gen. A. v. Boguslawski, of the German army. "The Saint Gobain Plate Glass Manufactory" describes a great French industry. "Sodor" describes and illustrates a siphon for the instantaneous preparation of soda water. Sir Joseph Norman Lockyer's "A Short History of Scientific Instruction" is concluded.

**Contents.**

(Illustrated articles are marked with an asterisk.)

Bicycle, chainless*.....	20	Inventions recently patented.....	23
Biograph in the Vatican*.....	24	Mortality statistics, present.....	22
Boilers, evaporation of modern.....	26	Mutoscope*.....	24
Book notices.....	25	National growth, areas of.....	23
Boston station*.....	17, 21	Oil trade, growth of our.....	19
Bridge, suspension, at Niagara.....	18	Powder, ideal smokeless.....	18
"Brooklyn," damage of, by Spanish shells*.....	27	Rail joint*.....	20
Education by correspondence.....	15	Soudan, railways and gunboats in the*.....	25
Education, new plan of.....	23	Station, Boston*.....	17, 21
Fermentation.....	20	Steamboats, types of.....	23
France and immigration of foreign*.....	26	Supplement, current.....	27
Guns, failure of cast steel.....	18	Tunnel, Moosic Mountain.....	20
Inventions, index of.....	29	Valve gear*.....	20
		Vatican, the.....	27

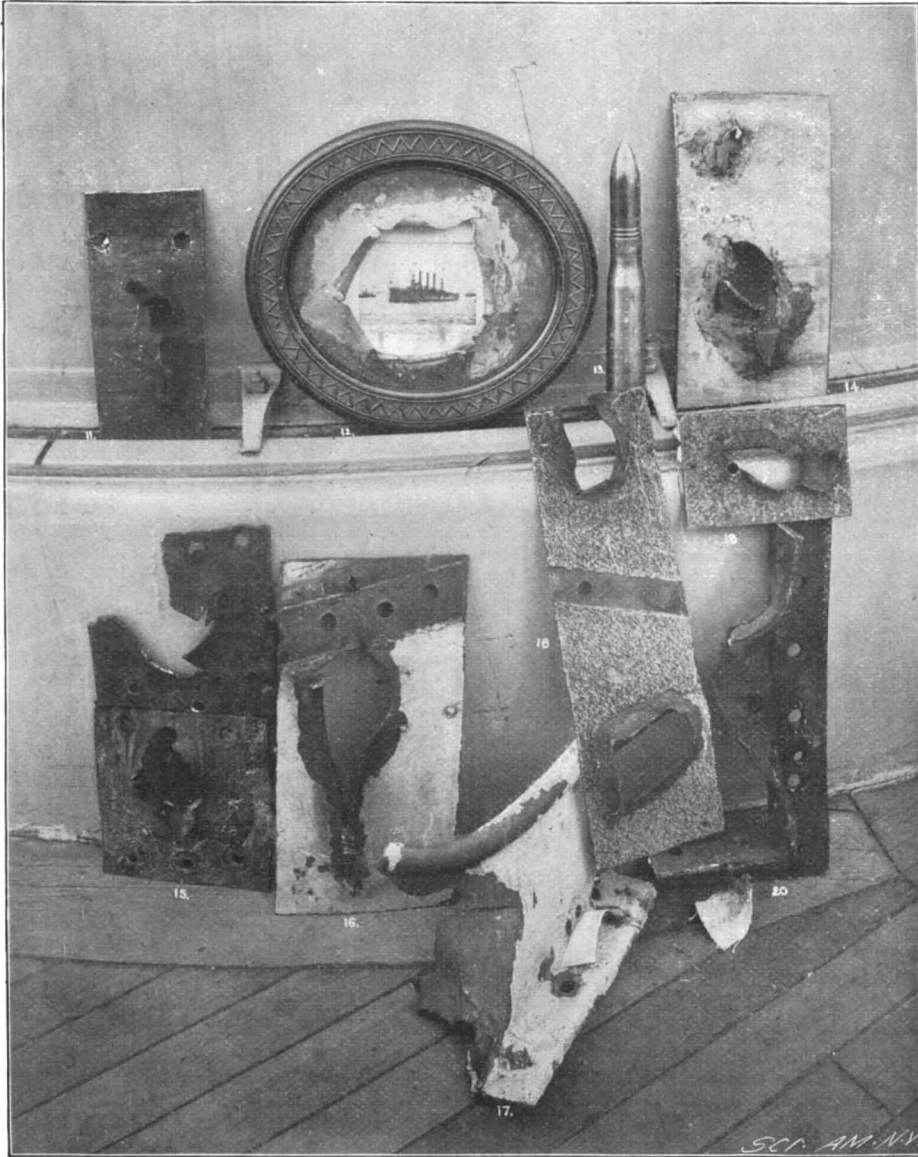

12, engine room ventilator; 13, Spanish 6-pounder shell from "Reina Mercedes"; 14, plate from hammock netting, penetrated by 6-pounder shell; 17, portion of deck beam on berth deck; 11, 15, 16, 18, 19, 20, smokestack casing on berth deck, pierced by fragments of 4'7-inch shell.

**EFFECT OF SPANISH SHELLS UPON THE "BROOKLYN."**

starboard side of the ship, the metal of which was from 3/8 to 1/2 inch in thickness.

The "Brooklyn" was placed in dry dock soon after her arrival at New York, where all the injured plates and other scars of active service were removed or else covered up by a new coat of paint. When she left the yard not a trace of the 47 wounds and scratches she received could be noticed by the casual observer.

THE Spanish vessels "Isla de Cuba" and "Isla de Luzon," sunk in the battle of Manila on May 1, have been raised and will be put into serviceable condition. The "Isla de Cuba," a vessel of 1,030 tons displacement and 2,200 indicated horse power, reached Hong Kong under her own steam.



Business and Personal.

The charge for insertion under this head is One Dollar a line for each insertion: about eight words to a line.

- Marine Iron Works. Chicago. Catalogue free.
For logging engines. J. S. Mundy, Newark, N. J.
"U. S." Metal Polish. Indianapolis. Samples free.

Notes & Queries

HINTS TO CORRESPONDENTS.

Names and Address must accompany all letters or no attention will be paid thereto. This is for our information and not for publication.

(7542) J. D. asks: How many pounds of compression is required to the inch to make liquefied air?

(7543) Q. writes: I have a battery composed of four Edison-Lalande cells. What charge should be used in the cells?

(7544) C. T. P. asks: 1. Would good Lowmoor iron forgings be better for the field magnets of the simple electric motor described in SCIENTIFIC AMERICAN SUPPLEMENT, No. 641, than the Russian iron and have them jointed at each end?

(7545) F. B. F. writes: 1. I have a motor made from the drawings and specifications in the SUPPLEMENT, No. 641, which I wish to convert into a dynamo.

No. 641, into a dynamo is one thing, to build a dynamo from the sketch inclosed is quite another thing. First, to convert the motor, connect to some source of power and run it up to full speed.

(7546) J. E. D. writes: 1. Treating on the velocity of falling bodies, Avery's "Physics," on page 107, example 53, statement is made as follows: "From an upper window drop simultaneously, from each hand, an iron and a wooden ball, both of same size, but varying in weight, and observe that both reach the ground practically at the same time."

(7547) W. J. K. asks: 1. What kind of lead is used for storage battery plates, cast or rolled? A. The plates of accumulator are of cast lead.

(7548) G. H. F. asks: Will the heater described in SUPPLEMENT No. 1112 work on alternating current? A. Certainly. One sort of electric current may be transformed into heat as well as another.

(7549) J. R. C. writes: Please give something of the construction of a repeating coil. Such as used in connecting a ground circuit with metallic telephone circuit.

(7550) C. O. H. writes: 1. I am about to make a new armature of the drum type for motor 641, as I think it will have double the efficiency with the same amount of wire.

the purpose with projections making grooves into which the coils are wound. These disks are about 3/8 inch thick. The armature will then be built as shown in SUPPLEMENT No. 600, price 10 cents.

(7551) T. E. says: 1. I intend to make a storage battery of six cells, having a capacity of 100 ampere hours to each cell. They will be made on the Faure system. What would be the highest amperage that could be used in charging them (without injury)?

(7552) W. M. P. asks: 1. How can I change the current of a small magneto (10,000 ohms) so as to get an even and smooth current as from batteries? A. By running it so fast that the impulses of the current are as rapid as those from the battery, which, we hardly need to say, cannot be done.

(7553) E. F. S. writes: For reply to question how to make an electric heater, you give me amount and size of wire to connect to arc light circuit.

(7554) W. B. B. writes: 1. I am building the simple motor described in SUPPLEMENT No. 641. Where shall I connect the battery to the machine, Fig. 9?

(7555) M. L. asks: What is the meaning or derivation of the word "Breguet," used in describing certain watch movements—as "Breguet half spring." The word is, of course, French, and cannot be found in dictionaries.

(7556) A. C. S. writes: In your issue of November 12, under Notes and Queries in answer to H. J. L., you stated that the alternating current taken

from the street line can be changed into a direct current by the use of a rotary transformer. Will you please publish in your paper for the benefit of the readers how such a transformer can be made?

(7557) J. L. B. asks: 1. Can you furnish me with a process of cutting an oval-shaped hole from a plate of double thickness glass, without boring? A. A hole is first to be drilled through the glass with a corner of a file wet with camphor dissolved in turpentine.

TO INVENTORS.

An experience of fifty years, and the preparation of more than one hundred thousand applications for patents at home and abroad, enable us to understand the laws and practice on both continents, and to possess unequalled facilities for procuring patents everywhere.

INDEX OF INVENTIONS

For which Letters Patent of the United States were Granted

JANUARY 3, 1899,

AND EACH BEARING THAT DATE.

[See note at end of list about copies of these patents.]

Table with 2 columns: Invention Name and Patent Number. Includes entries like Advertising apparatus, C. A. Rollason et al. 616,975; Air purifying and ventilating system, W. E. Whitney 616,977; Air tight lid, F. W. Forster 616,910; Alarm, See Bicycle alarm; Animal trap, J. H. Hoover 617,160; Auger, earth, Isgrig & Phares 616,928; Back pedaling brake, V. E. Doremus 616,907; Baking pan, cake, V. D. Allen 616,871; Bale tie making machine, Manville & Weeks 617,253; Barrel pitching machine, E. Rau 617,185; Battery, See Storage battery; Bearing, ball, O. C. Kulp 616,941; Bearing for wheels for agricultural machines, E. J. Corser 617,143; Beating apparatus, R. A. Gipple 617,063; Bed bottom, spring, E. J. Antoni 616,874; Bell, bicycle, A. W. Barton 617,220; Bell, bicycle, W. A. Butler 616,933; Bell clamp, bicycle, G. W. Eddy 617,240; Bending machine, C. Seymour 617,195; Bicycle, F. P. Bemis 617,273; Bicycle, M. L. Nichols 616,957; Bicycle alarm, G. F. Hall 617,013; Bicycle brake, A. M. Cushing 616,906; Bicycle brake, Meier & Turner 617,037; Bicycle driving gear, A. Gower 617,096; Bicycle folding basket attachment, McDonald & Norton 617,117; Bicycle fork crown, C. H. Smith 616,980; Bicycle parasol attachment, Harrison & Brown 617,096; Bicycle saddle, T. E. Beck 617,140; Bicycle safety attachment, Wilkins & Moore 617,136; Bicycle support, E. Koehler 617,028; Bicycle support, J. Leach 617,171; Bicycle valve, C. W. Beman 617,232; Billiard cue chalker, C. A. W. & D. Devore 617,271; Billiard cue holder, E. Beattie 617,221; Binder, temporary, Watters & Gould 617,035; Bldg. clover or flax attachment for self, W. Bauer 617,073; Bitumen from sand, method of and apparatus for extracting, A. S. Cooper 617,226; Boiler, See Steam boiler; Bolt holder, D. Shumate 617,129; Bone black, reactivating, C. Catlett 617,080; Bone black substituting and method of manufacture, C. Catlett 617,079; Bottle, S. E. Wharton 616,996; Bottle, non-refillable, J. R. Lavender 616,944; Bottle stopper, C. O. Roskoten 617,125; Box, See Clothes pin box; Brace, See Mining brace; Bracket, F. S. Jewett 617,164; Brake, See Back pedaling brake, Bicycle brake; Brake, Electromagnetic brake, Wagon brake; Brake apparatus, J. J. Kennelly 616,933; Bridge, movable, C. L. Strobel 617,201; Bridle bit holder, G. Schneider 617,300; Buckle, J. Polka 617,180; Buoy, electric, E. W. G. Hoffmann (reissue) 617,706; Burner, structure, H. M. Hunter 617,161; Burner, See Gas burner; Burner, W. R. Jeavons 617,291; Burner, Lannert & Jeavons 617,243; Burner attachment, B. Strauss 617,200; Button loop, J. Blumenthal 617,074; Calculating machine, H. Goldman 617,034; Calipers, J. H. Culver 617,082; Camera, magazine, A. L. Adams 617,268; Camera, magazine, A. Angel 617,255; Can opener, A. Fass 617,217; Cans, pitchers, etc., closing device for, J. Gawron 616,913; Cane wagon, sugar, M. R. Spelman 617,138; Canopy, head, S. Crocker 616,903; Car, air storage motor, R. Hardie 616,922; Car brake, S. Stitts 617,159; Car coupling, M. M. Bishop 616,881; Car coupling, E. C. Washburn 617,134; Car roof, double, C. H. Hutchins 617,284; Carding engine dividing apparatus, A. Lejeune 616,946; Carriage top storm curtain, J. T. Lawless 617,240; Case, See Show case; Casein with lithium salts, composition of, G. Wendt 617,214; Cement, treating blast furnace slag for, A. D. Eilers 617,241; Centrifugal machine, T. Henderson 617,158; Chair, See Wheeled chair; Chuck, E. Marcellie 617,113; Cigar band, A. E. Morris 617,245; Circuit closer, J. D. Garlock 617,287; Clamp, See Bell clamp, Cultivator shovel clamp, Jointing clamp; Clevis for regulating plow furrows, J. H. Nelson 616,955; Clevis, singletree, G. Thorsen 617,251; Clock bell, alarm, W. E. Porter 617,017; Clothes drier, J. H. Beardsworth 616,880; Clothes line reeler, W. Gilson 617,155; Clothes pin box or holder, R. C. Darner 617,284; Clutch, friction, H. W. Hill 617,088; Compass, beam, F. A. Hannah 617,011; Concrete breaking machine, Fairchild & Wilton 617,310; Cone and ball bearing, King & Egan 616,937



Founded by Mathew Carey, 1785.

HENRY CAREY BAIRD & CO. INDUSTRIAL PUBLISHERS, BOOKSELLERS & IMPORTERS 810 Walnut St., Philadelphia, Pa., U. S. A.

Our New and Enlarged Catalogue of Practical and Scientific Books, 92 pages, 8vo., a New Catalogue of Books on Steam, the Steam Engine, etc., and our other Catalogues, the whole covering every branch of Science applied to the arts, sent free and free of postage to any one in any part of the world who will furnish us with his address.



PURE WATER The RALSTON STILL placed upon your kitchen range will supply the family liberally with sparkling distilled water.

Queen Transits and Levels High Grade Instruments with the Latest Improvements. 160 page Engineering Catalogue on application.

The Typewriter Exchange 1 1/2 Barclay St., NEW YORK 156 Adams St., CHICAGO 38 Bromfield St., BOSTON 817 Wyandotte St., KANSAS CITY, MO.

TYPEWRITERS HALF PRICE We will sell you any typewriter made for one half regular price, many for one quarter.

National Health Club FREE MEMBERSHIP FOR 30 DAYS. Advantages Gained.

Health Appliances at Wholesale Prices. People are becoming educated in the use of many health appliances, such as Rubber Goods, Exercisers, Batteries, Massage Rollers, Vapor Bath Cabinets and many other devices.

WELL DRILLING Machines Over 70 sizes and styles for drilling either deep or shallow wells in any kind of soil or rock.

DON'T LEAVE YOUR KEYS in the front door. Fasten them to the pocket or waist-band with a key chain secured by the Improved Washburn Patent Fastener.

A.W. FABER Factory Established 1761. LEAD PENCILS, COLORED PENCILS, SLATE PENCILS, WRITING SLATES, STEEL PENS, GOLD PENS, INKS, PENCIL CASES IN SILVER AND IN GOLD, STATIONERS' RUBBER GOODS, RULERS, COLORS AND ARTISTS' MATERIALS.

PURE WATER is distilled water. Nothing but distillation will eliminate both organic and inorganic impurities. An ordinary cook stove is all you need with THE SANITARY STILL to give you plenty of pure, sparkling water, sweetened with sterilized air. Free booklet. Our \$10.00 STILL has twice the capacity of others. Write at once for particulars.

Table listing various mechanical parts and their prices, including items like 'Trousers hanger', 'Truck, piano', 'Tubes from metallic ingots', etc.

Table listing various designs and their prices, including items like 'Badge, Greenwood & Helmuth', 'Bicycle frame, J. L. Knoll', 'Bicycle saddle base, B. F. Wheeler', etc.

Table listing various trade marks and their prices, including items like 'Antidote to cocaine or any of its compounds', 'Bicycles and parts thereof', 'Bonbons, Walter M. Lowney Company', etc.

Table listing various labels and their prices, including items like 'Anglo-Saxon Brand Peaches', 'Catton, Bell & Company', 'Guarded Spring', etc.

PRINTS. "Fit Reform Clothing," for clothing, Saks & Company. "Fit Reform Garmets," for clothing, Saks & Company. "The Elgin Shirt," for shirts, Cutter & Crossette.

CAN I BECOME AN ELECTRICAL ENGINEER?

For our Free, handsomely illustrated book entitled "Can I Become an Electrical Engineer?" Address THE ELECTRICAL ENGINEER INSTITUTE OF CORRESPONDENCE INSTRUCTION, Dept. A.

WE WILL DOUBLE YOUR SALARY if you will study at home in spare time. Courses in Electrical, Mechanical, Civil and Mining Engineering, Mechanical Drawing and Machine Design, Architecture, etc.

METAL CHECKS, BADGES and PLATES OF ALL KINDS. A. WIEBKING, 603 Mildred Ave., Chicago.

FOR SALE One 24 light dynamo, one-eighth horse fan motor and one Burts Solar Compass with tripod complete.

DYNAMO AND MOTOR CASTINGS from 1/2 to 1 horse power. Send for Catalogue. Book telling how to make a 2 light dynamo, 10 cents.

TALKING MACHINES A SPECIALTY. MAGIC Lanterns Wanted and FOR SALE HARBACH & CO., 809 Fifth St., Phila., Pa.

DIES AND DIE MAKING Written for shop and tool-room use. 96 illustrations. Sent postpaid for \$1. J. L. Lucas, 10 Fuller St., Prov., R.I.

HANSON HYDRAULIC RAM. Brass delivery valve seat with leather washer. Superior air-sniff. Pumps at rate 1 ft. head to 30 ft. elevation; least head 2 feet.

A Well Known Firm in Russian Poland desires to represent business, preferably dealers in Sewing Machines and similar branches.

DORMAN'S VULGANIZERS are used all over the world. Exclusive Manufacturers of Steam Machines for Rubber Stamps.

THE J. F. W. DORMAN CO. 121 E. Fayette St., Baltimore, Md., U. S. A.

GOLD, SILVER, NICKEL AND METAL PLATING

NEW QUICK PROCESS. MODERN METHODS. PROFITS IMMENSE. You can positively make \$5 to \$15 a day, at home or traveling, doing Plating and selling Prof. Gray's Plating Outfits, Dynamos, etc.

Big Four Route

Chicago, Peoria, Cleveland, Indianapolis, to all FLORIDA POINTS. CHOICE OF ROUTES from CINCINNATI or LOUISVILLE.

POULTRY ROMANCE would make a good title for our 228-page BOOK ON POULTRY, for it reads like a romance.

The Wooden Hen A faultless hatching machine for 50 eggs. Price \$7. Heat and moisture regulation and ventilation, absolutely perfect.

WANTED.

GENERAL AGENCY or control for Pac. Coast of patented articles. W. H. Menkel & Co., San Francisco.

REFRIGERATION One to 25 tons daily capacity. Challoner's Sons, Oskosh, Wis.

ICE MACHINES, Corliss Engines, Brewers' and Bottlers' Machinery. THE VILVER MFG. CO., 899 Clinton Street, Milwaukee, Wis.

Electrical and Mechanical Model Work. M. E. SANGER, 62 Cortlandt St., New York.

FILMS & MACHINES FOR ANIMATED PHOTOGRAPHS

TURBINES Send for Catalogue "M." JAS. LEFFEL & CO., Springfield, Ohio, U. S. A.

EXPORT TO GERMANY We desire to represent manufacturers of Tools for metal working, Lathe, Drills, Grinding and Polishing Machinery, also wrought Iron Pipes and Fittings.

GAS AND GASOLINE ENGINES WATER MOTORS BACKUS WATER MOTOR CO. NEWARK N. J. U. S. A.

New Catechism of the Steam Engine For Engineers, Firemen, Mechanics and Amateurs. 480 pages, 325 illustrations.

AMERICAN DESK \$33.33 DELIVERED EAST OF THE MISSISSIPPI 60 inches long SEND FOR CATALOGUE

PRICES \$3.50-\$12.50 A FREE BOOK. How to get well and how to keep well, and look well. 90 per cent. of sickness can be avoided.

LOOK OUT! for fake affairs that pull over the head. Don't buy any cabinet before seeing it. We send on approval. Others dare not.

WE WANT LIVE AGENTS! 10,000 Cabinets sold in past 8 months by agents. Send this ad. and get FREE BOOK.

\$3 a Day Sure Send your address and we will show you how to make \$3 a day absolutely sure; we furnish the work and teach you free; you work in the locality where you live.

THE CYPHERS Incubator and Brooder The Only Practical System of Incubation. Moisture Self-Supplied and Regulation Absolute.

**THOROUGH INSPECTIONS**  
 AND INSURANCE AGAINST LOSS OR DAMAGE TO PROPERTY AND LOSS OF LIFE AND INJURY TO PERSONS CAUSED BY  
**STEAM-BOILER EXPLOSIONS**  
 J. M. ALLEN, PRESIDENT  
 J. B. PIERCE, SECRETARY  
 L. B. BRANNEN, ASST. TRES.  
 W. B. FRANKLIN, VICE PRESIDENT  
 F. B. ALLEN, 2ND VICE PRESIDENT  
 L. F. MIDDLEBROOK, ASST. SECT.

**A Happy New Year**



will be yours to enjoy as you never have before, if you are the happy owner of a  
**WINTON MOTOR CARRIAGE**

We have more than doubled our facilities, but it will be necessary to order early to secure delivery. Ours is the hydro-carbon system. Variable speed motor. One-half cent per mile. Write for information.  
 Price \$1,000. No Agents.  
**THE WINTON MOTOR CARRIAGE CO.,** Cleveland, Ohio.

**Emery Grinds--Carborundum Cuts**  
 That is why Carborundum does so much Faster and Cleaner work.  
**THE CARBORUNDUM CO.,** NIAGARA FALLS, N. Y.

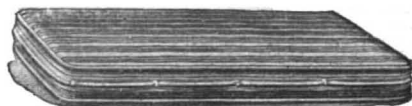

"Perfection" Yacht Mattresses and Cushions. Every yachtman knows what it is to have wet bedding on a yacht. "Perfection" Mattresses are moisture resisting, non-absorbent, and vermin proof. We make to order any size or shape of mattresses and cushions. Write for catalogue. Send measurements for estimates.  
**MECHANICAL FABRIC CO.,** Providence, R. I., U. S. A.

**FOR FIRE PROTECTION,** which means Cheap Insurance, put in a  
**CALDWELL TANK AND TOWER**  
 Endorsed by the leading Insurance Companies.  
**W. E. Caldwell Co.,** 217 E. Main Street, LOUISVILLE, KY.

**FREE** to Manufacturers. West Shore R. R. Shops (brick buildings 75x200 feet) R. R. tracks run into buildings, also sites on line of W. S. and C. & E. Railroads and Erie Canal. J. H. McCartney, Frankfort, N. Y.

**WE HAVE FOR SALE**  
**ONE POWER PUMP**  
 BUILT BY THE  
**WATERBURY FARREL FOUNDRY AND MACHINE CO.**

This pump is built with separate valve chambers and four single-stroke cylinders, 5 in. in diameter by 12 in. stroke, driven through gears designed to give the pump a normal speed of about fifty revolutions per minute, with a delivery of about 200 gallons per minute. The pump is capable of pumping against a pressure of 1000 lbs. per square inch.

- All the pressure parts are made of air furnace gun iron, which have been used but little.
- The extra parts for the above include:—
- 4 cylins extra complete.
- 4 plungers and outside rods to connect same.
- 2 cross heads and connecting rods complete.
- 2 slides for cross heads.
- 2 babbitted bearings for driving shaft.
- 2 caps for main bearings, with bolts and adjusting screws.
- 1 four-branch discharge fitting, finished complete.
- 1 planed, not drilled.
- 4 valve chambers complete.
- 2 valve seat castings, finished.
- 1 valve bonnet casting, rough.
- 4 glands, finished (brass).
- 1 gland, rough (brass).
- 1 3 inch Frazz & Gady valve.
- 1 piece of shafting, 4 15-16 in. diameter, with pinion attached.
- 1 coupling for above.
- 1 large gear, same pitch as above.

We have also for sale an accumulator, formerly working in connection with the above. This accumulator has a plunger 12 in. in diameter by 12 ft. stroke.

- Included with the above are:—
- 2 special valves.
- 2 safety valves.
- 3 sets of cushioning springs.
- 2 boiler iron supply tanks, 5 feet in diameter by 7 feet deep.
- Regulating attachment for working by-pass direct from the accumulator.
- Cast iron weights for the accumulator amount to 45 tons, 104 pieces weighing 881 lbs. each, and 8 pieces weighing 415 lbs. each.

**MOTOR CARRIAGE DEPT.,**  
**POPE MFG. CO.,** HARTFORD, CONN.

**GUNDLACH OPTICAL CO.**  
 761 765 S. CLINTON ST.  
 ROCHESTER, N. Y.  
 MANUFACTURERS OF  
**PHOTOGRAPHIC APPARATUS**  
 OUR NEW CYCLE OUTFIT CAN'T BE BEATEN FOR QUALITY OR PRICE.

A First-Class  
**MICROSCOPE**  
 And Outfit for Work for  
**\$16.00**  
 A Reliable Scientific Instrument  
 Just the Thing for Winter Evenings as well as Summer Afternoons  
 An inexhaustible mine of amusement and information for young and old. Easy to use. Perfect optical results. One may use the microscope a lifetime and never look at the same thing twice.  
 Outfit consists of microscope as shown, twelve prepared objects, such as fly's wing, foot of insect, etc., book describing and illustrating 1,000 common microscopic objects, glass slides, and covers for mounting objects, forceps, etc.  
 Microscopes, all prices, up to \$500.00  
**BAUSCH & LOMB OPTICAL CO.**  
 Rochester, N. Y.  
 NEW YORK CITY CHICAGO  
 Magnifies 180 diameters (32,400 times).

"Universal" Kneading and Mixing Machines  
 Over 6200 in use. Over 300 varieties in 155 different industries. Patented in all countries.  
**WERNER & PFLIEDERER**  
 Saginaw, Mich. Builders of all kinds of Chemical Machinery, also at Cannstatt, London, Vienna, Berlin, Paris and Moscow. 83 Highest International Awards.

**AUTOMATIC MICROTOME**  
 An instrument for cutting minute sections down to the ten-thousandth of an inch. Cuts clean, quick and automatically by the touch of a lever. In use throughout the world. Manufactured by **JOSEPH ZENTMAYER**, 211 So. 11th St., Phila., Pa. Fine Instrument Making and Repairing.

**AUSTIN SEPARATOR**  
 Unequaled for DELIVERING DRY STEAM by eliminating moisture and condensation from LIVE STEAM. Also EXTRACTING OIL, GREASE, and other impurities from Exhaust Steam. Manufactured by **AUSTIN SEPARATOR CO.**, 27 Woodbridge Street West, Detroit, Mich.

**MAGIC LANTERNS**  
 and STEREOPTICONS—all sizes, all prices. VIEWS illustrating all timely subjects—latest War Scenes, etc. Fine thing for Church Entertainments and for illustrating sermons. Men with small capital make money giving Public Exhibitions. 256 page catalogue Free. **McALLISTER, Mfg. Optician**, 49 Nassau St., N. Y.

**You Can Build This Engine**  
 with castings, outfit and instruction drawings. This is the best of practical mechanical training. This set for 1/4 H. P. \$3.00; 1/2 H. P. \$5.00. Send stamp for free illus. list No. 834 of tool bargains showing how you can save up to 50%.  
**The Frasse Company, 21 Warren Street, New York.**

**TIME RECORDER**  
 The Rochester Card System keeps the record for a full week on a small card. See Illustrated Editorial Sect. AMER., Dec. 24, 1888.  
**WILLARD & FRICK MANUFACTURING CO.** ROCHESTER, N. Y.

**THE CHARTER GAS AND GASOLINE ENGINE**  
 SAFE, CLEAN, NEAT, SIMPLE, RELIABLE, COMPACT.  
 NO FIRE, NO COAL, NO BOILER, STEAM OR SMOKE, NO DANGER.  
**CHARTER GAS ENGINE COMPANY,** BOX 148, STERLING, ILL.

**Scales**  
 All varieties at lowest prices. Best Railroad Track and Wagon or Stock Scales made. Also 1000 useful articles, including Safes, Sewing Machines, Bicycles, Tools, etc. Save Money. Lists Free. **CHICAGO SCALE CO.,** Chicago, Ill.

**Blodgett**  
 Comb, twist drill, thread pitch, center and top drill gauge.  
 Price, \$1.50 each.  
 Gauge and 510 page catalog sent postpaid for \$1.40 or catalog alone for 25c.  
**MONTGOMERY & CO., TOOL MAKERS,** 105 FULTON STREET, NEW YORK CITY.

**MARINE & STATIONERY ENGINES**  
 \$200 & OVER  
**GRAND RAPIDS**  
 GAS ENGINE & YACHT HORSE POWER  
 BRANCH 12 EXCHANGE PLACE, NEW ORLEANS, LA. CC 1-2-3- CYLINDER

"TRADE MARK"  
**"PEGAMOID" ENAMELETTE.**  
 A waterproof composition not affected by petroleum, kerosene, benzine, turpentine, linseed, cottonseed or castor oils, salt air, water or atmospheric influences. Unequaled for tanks, barrels, tunnels, machinery in damp places, hulls of vessels, cottages near the ocean, interior work and decoration. In all colors. Samples by mail for 25 cents.  
**THE AMERICAN PEGAMOID CO., 348 B'way, New York.**

**RUST PREVENTOR**  
 ON GUNS TOOLS & BICYCLES  
**PREVENTOR**  
 C. M. SLY & CO. CHICAGO ILL. U.S.A.  
**THE CELEBRATED GRANGER BOOT**  
 The very best heavy boot that can be made, the product of fifty years of boot making skill. First class in every respect. Old fashioned bench work. French kip uppers, double, oak-tanned sole. Suitable for Prospectors and Engineers. Circulars free.  
**M. A. SMITH & SON, Boot Makers** for all uses, Dress, Riding and Hunting, 25 & 27 North 13th St., Philadelphia.

**MIETZ & WEISS KEROSENE ENGINE.**  
 The most economical power known. Absolutely safe and reliable. Runs with common kerosene. Perfectly automatic. Patented 1897, U. S. and European countries.  
 128-132 Mott St., New York.

**Power? Power? Power!**  
**RACINE GAS AND GASOLINE ENGINES.**  
 LOCAL ENGINE AGENTS WANTED  
 Racine Steam and Vapor Launches. Racine Row and Sail Boats. Send stamps for Catalogue. Specify one wanted.  
**CARSE BROS. CO.,** 64-66 Wabash Ave., Chicago.

This beats Wind, Steam, or Horse Power. We offer the **WEBSTER 2 1/2** actual horse power **GAS ENGINE** for \$150, less 10% discount for cash. Built on interchangeable plan. Built of best material. Made in lots of 100 therefore we can make the price. Boxed for shipment, weight 800 pounds. Made for Gas or Gasoline. Also Horizontal Engines, 4 to 30 horse power.  
 Write for Special Catalogue.  
**WEBSTER MFG. CO., 1074 West 15th St., CHICAGO**  
 Eastern Branch, 38-D Dey Street, New York City.

**GAS and GASOLINE ENGINES.**  
 Using Natural Gas, Coal Gas, Producer Gas, and Gasoline direct from the tank. 1 to 40 H. P., actual.  
**The Springfield Gas Engine Co., 21 W. Washington St. Springfield, O.**

**SECTORLESS WIMSHURST MACHINE.**  
 This article gives directions for making a 4 illustration. SCIENTIFIC AMERICAN SUPPLEMENT, 1131. Price 10 cents. For sale by Munn & Co. and all new-dealers. Send for new catalogue.

**A WONDER IN WHEELS**  
 Bicyclists who desire safety under all conditions, who are fond of coasting, but like to have their machine under complete control in every emergency, should try the  
**ECLIPSE BICYCLE** with Morrow Automatic COASTER AND BRAKE  
 The rear sprocket has an Automatic Clutch which is thrown out of gear by holding pedals still. You COAST with feet on pedals. Back pressure upon them instantly applies brake, forward pressure as quickly releases it. Simple, Safe, Sure. Write at once for particulars and prices to  
**ECLIPSE BICYCLE COMPANY, Box X, ELMIRA, N. Y.**

**HIGH GRADE FOOT POWER LATHES**  
 W. F. DAVIS, ROCHESTER, N. Y.  
**Practical and Reliable Motor Carriages**  
 Two, Four and Six Passenger Pleasure Carriages, Doctors' Carriages, Business and Delivery Wagons. No trouble, no vibration. Strong Power. Will go any distance over any road at any speed. Easily managed, durable and convenient. Our 1898 designs will be ready after January 1st. If you want a Motor Carriage for spring delivery, get your order in now. Send ten cents for our beautifully illustrated and descriptive catalogue.  
**THE HAYNES-APPERSON CO.,** Kokomo, Ind., U. S. A.

**Criborne Bicycles**  
**\$50.00 and Upward.**  
  
**THE BEST IN THE WORLD.**  
 Handsome illustrated catalogue describing our full line of twenty-three models mailed free.  
**The Black Mfg. Co., Erie, Pa.**

**Calcium King Lamp.**  
 BURNS ACETYLENE GAS. No Oil, Wick, Dirt or Smoke. Get the Best. Price \$3.50. Agents wanted in every town.  
**CALCIUM KING LAMP CO.,** Waterbury, Conn.

**"American-Hunnings" TELEPHONES.**  
 Transmitters, Magneto Bells and Telephone Switchboards. Over 200,000 of our telephones in successful operation. Used by War and Navy Departments. In ordering state length of line, whether single line or metallic circuit and number of telephones to be used on one line. Send for catalogue "S. A."  
**AMERICAN ELECTRIC TELEPHONE CO.,** 173 South Canal St., Chicago, Ill.

**Buy Telephones**  
 THAT ARE GOOD—NOT "CHEAP THINGS." The difference in cost is little. We guarantee our apparatus and guarantee our customers against loss by patent suits. Our guarantee and instruments are both good.  
**WESTERN TELEPHONE CONSTRUCTION CO.** 250-254 South Clinton St., Chicago.  
 Largest Manufacturers of Telephones exclusively in the United States.

**"AN INTRUDER"**  
 will think a long while if he knows there is a **SMITH & WESSON** Revolver in the house.  
 All calibers; long or short barrel.  
 Write for Descriptive Catalogue.  
**SMITH & WESSON,** 14 Stockbridge St., Springfield, Mass.

**HOISTING ENGINES**  
 operating on GASOLINE, DISTILLATE OR CRUDE OIL. Both Friction and Geared Hoist, from 10 to 50 H. P., for Mines, Quarries, Docks, etc. Great Savings over steam, especially where wood, coal or water are scarce. Send for catalog. Guaranteed fully. State size wanted. Address **Weber Gas and Gasoline Engine Co., 402 S. W. Boulevard** Kansas City, Mo.

**GEO. H. GERE YACHT AND LAUNCH WORKS.**  
 FINE CABIN AND GRAND RAPIDS WORKS  
 OPEN LAUNCHES  
 Genl. U. S. Canada Sales Agt. for **MONITOR GASOLINE VAPOR ENGINES**  
**JESSOP'S STEEL** THE VERY BEST FOR TOOLS, SAWS ETC.  
**WM JESSOP & SONS** 91 JOHN ST. NEW YORK  
**PRINTING INKS**  
 The SCIENTIFIC AMERICAN is printed with CHAS. ENEU JOHNSON & CO.'S INK, Tenth and Lombard Sts., Philadelphia, and 47 Rose St., opp. Duane, New York