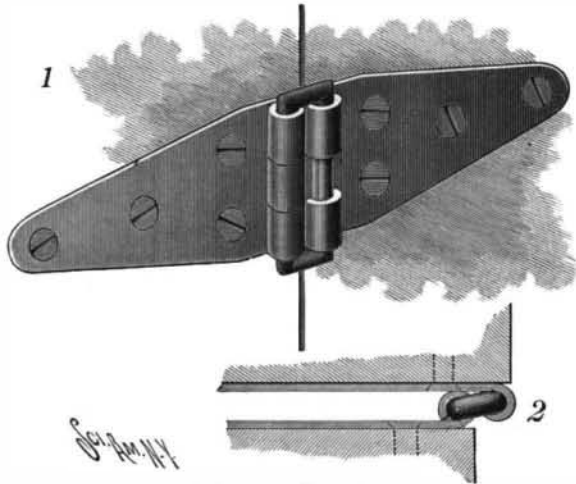

A NOVEL HINGE.

Of the accompanying illustrations, Fig. 1 represents a perspective view and Fig. 2 a broken plan view of a recently patented improvement in strap or butt hinges which embodies an advantage in the direction of strength while preserving simplicity of construction without appreciably increasing the cost. By this invention each strap or butt has a plurality of knuckles, a double pin being employed, each leg of which has its complement of aligning knuckles. The cut shows a strap hinge embodying the improvement. One strap

**FARRAR'S HINGE.**

is provided with three knuckles, the middle one extending beyond the other two. The companion strap has an upper and a lower knuckle, which, when the parts of the hinge are assembled, receive between them and align with the central projecting knuckle of the other strap. The legs of a double or link-pintle pass through the registering knuckles of both straps or butts. With this construction each strap has virtually an independent pintle and a plurality of knuckles; yet both straps are so connected by the same pintle that they will work freely. By thus distributing the strain at the knuckles, it is claimed, greater strength will result without increasing the bulk or cost. The center of the hinge shifts around when the door swings, and by making the knuckles perfectly round, the straps can fold back closely together.

The invention has been patented by John J. Farrar, of Rapid City, South Dakota.

A NOVEL WEIGHING AND DELIVERING MACHINE.

An ingenious weighing machine, designed to weigh and deliver accurately and automatically powdered, granular or similar material, such as flour, sugar, coffee and the like, and, at the same time, to register the amount thus weighed, has been devised and patented by Prof. Shanker Abaji Bhise, F.S.Sc., President of the Bombay Scientific Club, of 2 and 4 Cathedral Street, Ramwadi Market Post, Bombay, India.

The machine, as shown in our illustration, comprises

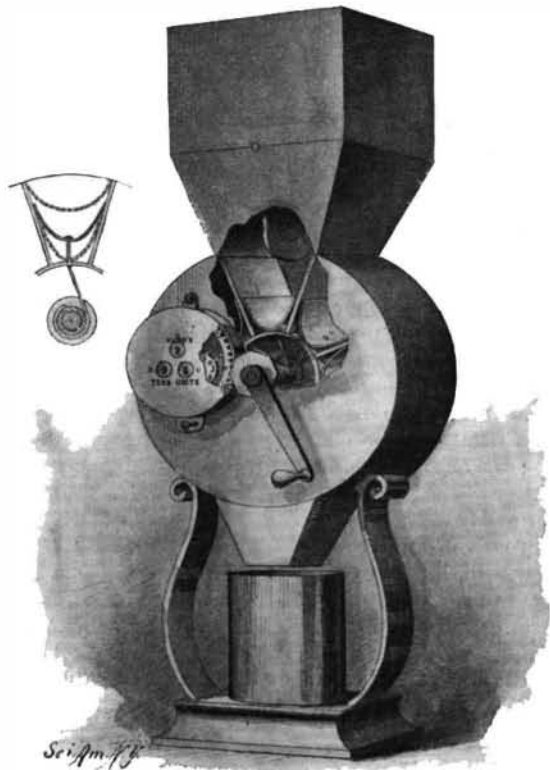
**BHISE'S IMPROVED WEIGHING AND DELIVERING MACHINE.**

a suitably supported cylindrical casing having a feed hopper adapted to receive the material to be weighed. The measurer is carried in the casing and consists of a series of radially arranged receivers mounted on a suitably driven horizontal shaft. While the material is pouring into the uppermost receiver, the lowermost receiver is discharging. Means are provided whereby differences of weight per cubic inch are compensated for. This is accomplished by providing each compart-

ment with a false elastic bottom bent so as to enable it to be introduced in the receiver, which bottom, owing to its resilience, normally tends to rise and expand at its ends to reduce the size of the receiver. Each elastic bottom has a flexible strand or chain secured to its center and extending to a rotatably adjustable sleeve on the shaft. A rotatable movement of the sleeve thus adjusts the positions of all the bottoms simultaneously.

A registering mechanism is provided, whereby the amount of material weighed may be quickly ascertained. A pinion on the shaft of the measuring cylinder meshes with a main spur gear, and a series of registering wheels are provided with spaced radial projections which are engaged by a series of changeable, spaced, radial pins projectable from the spur gear. The frequency of the impulses given to the unit wheel, and by it to the other registering wheels, may be increased or diminished by increasing or diminishing the number of projecting pins.

Prof. Bhise informs us that he invented the machine in response to a call in *The Inventor's Review and Scientific Record*, London, and in competition with several inventors won the prize which was offered.

Railroad Mileage of Europe.

At the beginning of the year 1897, there were, in all Europe, 159,025 miles of railroads in operation, this being an increase during the year 1896 of 3,144 miles, says Consul Du Bois, of St. Gall. Of this increase, Austria-Hungary had 806 miles, of which Hungary had 579 miles. In Russia, there was an increase of 555 miles. This, of course, does not include the great transsiberian and transcaucasian lines, with their 2,883 miles, a large portion of which has recently been opened to traffic. Germany increased her railroad mileage 579 miles—the same as Hungary—the kingdom of Prussia receiving 387 miles.

The countries of Europe now having the most railroads in operation, according to their areas, are, in their order: Belgium, 3,582 miles; Great Britain and Ireland, 21,217 miles; Germany, 29,355 miles; Switzerland, 2,209 miles; Holland, 1,608 miles; France, 25,089 miles. The other countries of Europe have the following railroad mileages: Austria, 18,951; Denmark, 1,605; Spain, 7,615; Greece, 590; Italy, 9,349; Luxemburg, 269; Portugal, 1,451; Roumania, 1,784; Russia proper, 22,455; Finland, 1,484; Servia, 335; Sweden, 6,073; Norway, 1,201; Turkey and Bulgaria, 1,507; the islands of Jersey, Malta and Man, 68 miles.

THE "OLIVE" BICYCLE.

We present herewith sectional views of the crank hanger arrangement and seat-post adjusting devices which, in conjunction with other features, are distinguishing characteristics of the "Olive" wheel, manufactured by the Olive Wheel Co., of Syracuse, N. Y.

Referring to our illustration, it will be seen that the V-shaped end of a boss formed integrally with the sprocket-wheel fits into a similarly shaped recess in the axle, on the opposite end of which is integrally formed one of the pedal cranks. The other pedal crank is placed against the outer face of the sprocket wheel. A threaded bolt passes through this separately formed pedal crank into the sprocket wheel and its boss, and enters the axle at its recessed end. A collar fitting over the boss inwardly from its V-shaped end forms the cone bearing at the sprocket-wheel side of the hanger. The other cone bearing is formed by a threaded sleeve on the opposite end of the axle. The simplicity of this construction readily permits the various parts to be removed and cleaned, merely by unscrewing the connecting bolt.

Turning now to our other illustrations, it is seen that the saddle-post telescopes into the usual seat-mast and is provided at its front portion with orifices. The triangular space left between the post and the top tube receives a wedge-shaped block having projections adapted to fit into the orifices of the post. When it is desired to alter the position of the saddle, the post and its block are raised and the block made to engage the desired orifices to give the required adjustment; the post is then lowered until the block meets the frame. A transverse fastening device engages the block and frame and prevents the accidental displacement of the several parts. By this simple adjustment, the use of nuts, screws, bolts and wrenches is dispensed with so far as this portion of the bicycle is concerned.

The University of Paris has been authorized to borrow \$340,000 for the construction on the Rue Cuvier of buildings and laboratories for instruction in the sciences preparatory to the study of medicine, and for the completion of the laboratory of physiological botany at Fontainebleau.

AN IMPROVED CUTTER BAR.

The illustrations which we present herewith represent an improvement in cutter bars recently patented by Charles E. Frye, of Wilton, New Hampshire. Mr. Frye's cutter bar is so constructed that each blade will be contained in an independent pocket, means being provided by which a single cap will lock all the blades in position. Of our illustrations, Fig. 1 is a perspective view showing a short portion of the cutter bar, Fig. 2 presents a longitudinal vertical section, Fig. 3 a partial plan view with the cap removed, and Fig. 4 a bottom plan view of the cap. The cutter bar is provided at intervals with blocks or projections, each wider at one end than at the other to form a projecting flange at the back and front edges. The under side of the wide end of the block is recessed to produce an overhanging lip which projects toward the inner end of the cutter bar. Blades formed with T shanks are so proportioned as to enable the shanks to enter the spaces between opposing blocks and to lie partly beneath the previously mentioned flanges and lip. A

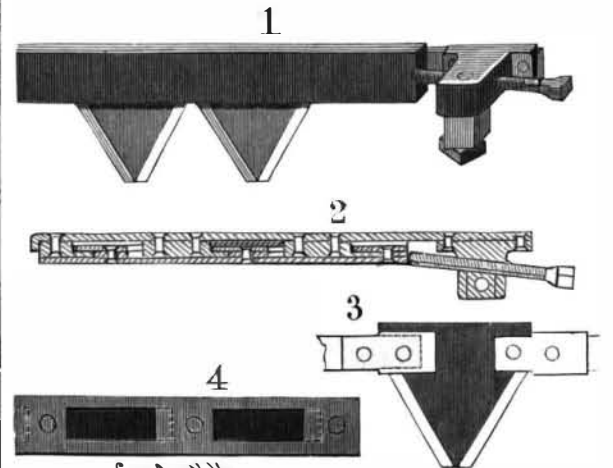
**FRYE'S CUTTER BAR.**

retaining cap is provided with depressions from which end recesses extend. The cap is thus made to fit over the blades, the depressions receiving the bodies of the blocks and the end recesses receiving the lips of the respective blocks.

In assembling the parts, one edge of a blade is entered beneath the lip of a block until the blade can seat itself on the bar. The extended portions of the T shanks prevent transverse movement. The retaining cap is now fitted over the blocks so as to cause each end recess to receive the lip of the corresponding block, and the set screw shown in our first two illustrations locks the cap tightly into place, preventing all independent movement of the parts.

Sensation of Hanging.

A captain who was rescued from the gibbet at the intercession of Viscount Turenne, after being partially hanged, related that, having lost all pain in an instant, by being rescued he had been snatched from a glorious light, the charm of which defied all description. All victims of partial hanging agree that the uneasiness is quite momentary; that a pleasant feeling succeeds, and that various colors start before the sight, casting everything else in oblivion. The mind, averted from reality, is engaged in scenes most remote from

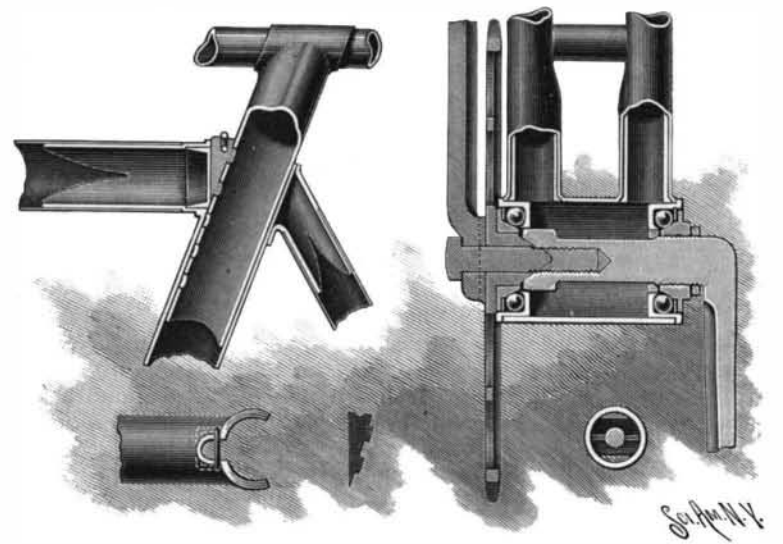
**THE "OLIVE" BICYCLE FRAME.**

that which fills the eye of the spectator—the hideous gallows and the struggling form.

[The above from *The Medical Council* may be comforting to some one. An acquaintance related to the writer similar pleasant sensations he experienced when so near drowning he had lost all consciousness, and was, with great difficulty, resuscitated.—Ed.]

DR. JULES MARCOU, the geologist, died on April 17, at the age of seventy-five years.