

AN ANGULAR BIT STOCK.

An extremely convenient form of holder for a chuck or head for small drills or other boring tools, enabling the drill to be placed and locked at any angle to the shank of the holder, or the stem communicating power to the drill, is shown in the accompanying illustration. The device has been patented and is manufactured by C. A. Meister, of No. 726 Union Street, Allentown, Pennsylvania. The device comprises pivotally con-

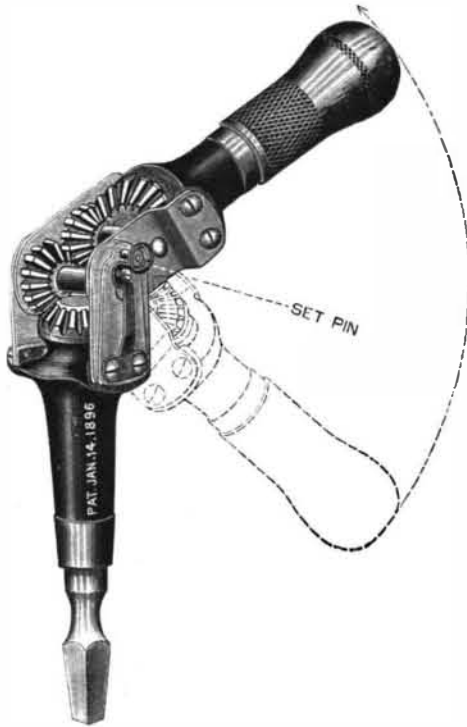

MEISTER'S ANGULAR BIT STOCK.

needed frame sections, one section consisting of a sleeve having a fork at one of its ends, and the other section having side pieces, a transverse shaft pivotally connecting the side pieces of one section with the fork of the other section. This shaft has a gear wheel meshing with a bevel gear on a driving shaft in the sleeve of the forked section, whereby motion is communicated to an intermediate and a bevel gear of the tool-carrying section. By means of a set pin, shown in the illustration, the tool-carrying chuck may be carried around, as indicated by the dotted lines, and set and locked at any desired angle to the bit brace. The gear attached to the chuck is $1\frac{1}{2}$ inches in diameter, while the other gears are only 1 inch, giving more power to the bit than if the gears were all of one size.

Food Lost in Cooking.

Experts connected with the experiment stations of the United States Department of Agriculture have been making some interesting tests showing the losses in the boiling of vegetables and the composition and digestibility of potatoes and eggs, says The New York Sun. A. C. True, director of these experiment stations, remarks that, although the greater part of the food of man is prepared for use by cooking, yet the changes which various foods undergo during the process and the losses which are brought about by cooking have been little studied. Prof. H. Snyder, Dr. Almah J. Frisby and Dr. A. P. Bryant have just completed some investigations on the loss of nutrients in boiling potatoes, carrots and cabbages; also on the composition and digestibility of potatoes and eggs.

Few persons know that in 100 pounds of uncooked cabbage there are but $7\frac{1}{2}$ pounds of dry matter, and of this dry matter from $2\frac{1}{4}$ to 3 pounds are lost in the process of cooking. This loss seems to be unavoidable, unless the cabbage is cooked in such a manner that the water in which it is boiled is also used. This is frequently the case when cabbage is cooked with corned beef. In the experiments made at the government stations, potatoes, carrots and cabbages were selected as being the best representatives of tubers, roots and pot herbs.

The conclusions drawn from the experiments with potatoes are substantially as follows: First.—In order to obtain the highest food value, potatoes should not be peeled before cooking. Second.—When the potatoes are peeled before cooking, the least loss is sustained by putting them directly into hot water and boiling as rapidly as possible. Even then the loss is very considerable. Third.—If potatoes are peeled and soaked in cold water before boiling, the loss of nutrients is very great, being one-fourth of all the albuminoid matter. In a bushel of potatoes the loss would be equivalent to a pound of sirloin steak.

Although carrots contain less nitrogen than potatoes, they are found to contain relatively more albuminoid nitrogen, and therefore to furnish more matter available for building muscular tissue. From the experiments with carrots the following conclusions are deduced: In order to retain the greatest amount of nutrients in the cooking of carrots, the pieces should be large rather than small; the boiling should be rapid, in order to give less time for the solvent action

of the water to act upon the food ingredients; as little water as possible should be used, and if the matter extracted be used as food along with the carrots, instead of being thrown away, the loss of 20 to 30 per cent or even more of the total food value may be prevented.

Experiments analogous to those with potatoes and carrots were made with cabbages, to determine the loss of food material during the process of preparation for the table. Cabbages represent the class of pot herbs in which the leaves are the edible portion. They expose more surface to the action of the water than do tubers or roots. The kind of water used has more effect on the loss of nutrients in cooking cabbage than the temperature of the water at which the cooking is started. In any case the loss is large.

The purpose of these experiments just completed is to learn what actually takes place in the process of preparing food by the common methods. The losses which occur in the cooking of potatoes, carrots and cabbages vary with the different methods of boiling followed. While the net loss is not so great as to render it imperative that people in comfortable circumstances should abandon methods of preparing these foods which they consider make them most palatable, there are believed to be many persons who cannot afford to permit even the comparatively small waste of food observed in these experiments.

In the tests with eggs, it was shown that, while the method of cooking has some effect upon the rate of digestibility, it does not materially affect the total digestibility. Rubner, in an experiment with man, found that 79.1 per cent of the nitrogen of hard-boiled eggs was digested.

AN IMPROVED DIFFERENTIAL BICYCLE GEAR.

The accompanying illustration represents improvements in bicycle gear designed to allow a rider to readily and conveniently change from a low gear to a high gear, and vice versa, the construction being strong, simple and comparatively inexpensive, and the arrangement being such that the friction is reduced to a minimum. Figs. 1 and 2 show the invention as most recently improved, and Fig. 3 represents the gear according to a patent granted some weeks ago, the inventor being Mr. Guy R. Balloch, of Centerville, New Brunswick, Canada. As represented in Fig. 3, the hollow hub of the drivewheel turns at its sides on ball bearings, one bearing being supported from a hollow axle and the other being carried by the sprocket wheel supported from the hollow axle, so that the hub and the sprocket wheel turn independently of one another. On the inner faces of the sides of the hub are bevel gear wheels of different diameters, adapted to be alternately engaged by two inner gear wheels, forming a double gear rotating on ball bearings on a disk eccentric to the hollow axle. The double gear wheel is adapted to slide laterally in the hub and is rotated from the sprocket wheel. The lateral movement of the double gear wheel, to engage either of the hub differential gears, is effected by means of a spring-pressed hand lever extending under the handle bar, in convenient reach of the rider, and by means of a high and low gear can be made use of whenever desired. The entire device is completely inclosed within the hollow hub, and hence is thoroughly protected from dust and is not liable to get out of order. According to the improvement represented in Figs. 1 and 2, the hollow drive wheel hub is provided with a gear wheel and clutch teeth, a gear wheel being mounted to turn with and held to slide on the hub of the sprocket wheel, the slidable gear wheel being provided with clutch wheel for engagement with the hub clutch teeth. There is a double gear wheel eccentric to the slidable gear wheel and the hub gear wheel, one of the gear wheels of the double gear wheel being in mesh with the hub gear wheel, and the other gear wheel of the double gear wheel being adapted to be engaged by the slidable gear wheel at the time the clutch teeth of the latter are out of mesh with the hub clutch teeth. The entire device is completely inclosed within the hollow hub, and the change of gear is similarly effected by a lever extending up under the handle bar.

PREVENTIVE medicine as a science has wholly arisen during the reign of Queen Victoria, says The Independent, and it is a curious fact that the only sanitary law on the statute book—the Quarantine Act of 1825—was, on the eve of the Diamond Jubilee, erased from the statute book as a vexatious measure no longer to

be tolerated. The first step in modern sanitation was the registration of vital statistics, which began in the first year of Victoria.

AN INVISIBLE BRAKE FOR BICYCLES.

All tourists' bicycles are not provided with a brake, although all ought to possess one, even though it might have to be used only on very rare occasions. One of the reasons (a bad but strong one, like all bad reasons) for the disfavor in which the brake is held by a large number of bicyclists is that it spoils the appearance of the machine. As an answer to this, it might be said that safety should be considered before elegance; but to make such an assertion would be a waste of time. Another fault found with the brake (chiefly by women) is that, in a lengthy descent, the necessity of holding it tightly tires the right hand.

A brake that was invisible and that kept up the desired degree of friction indefinitely would, therefore, prove welcome by setting at naught the two principal objections that we have just formulated.

Such a brake has been in existence for the last two years. It was devised by an Englishman, Mr. Alfred



INVISIBLE BRAKE FOR BICYCLES.

Williams, and a representation of it is given in the accompanying figure.

The block of this brake, which is concealed beneath the crown of the fork, is mounted upon a rod, which is itself concealed in the steering head. This rod terminates above in a rack, with which engages a small pinion that may be revolved in one direction or the other by turning the right hand grip. The transmission of the revolution of the grip to the pinion is effected through the intermedium of a series of joints arranged in the interior of the right hand branch of the handle bar. The friction of all these joints in the handle bar is sufficient to keep the pinion firmly in place in the position that is transmitted to it in acting upon the grip. In this way, owing to such ingenious

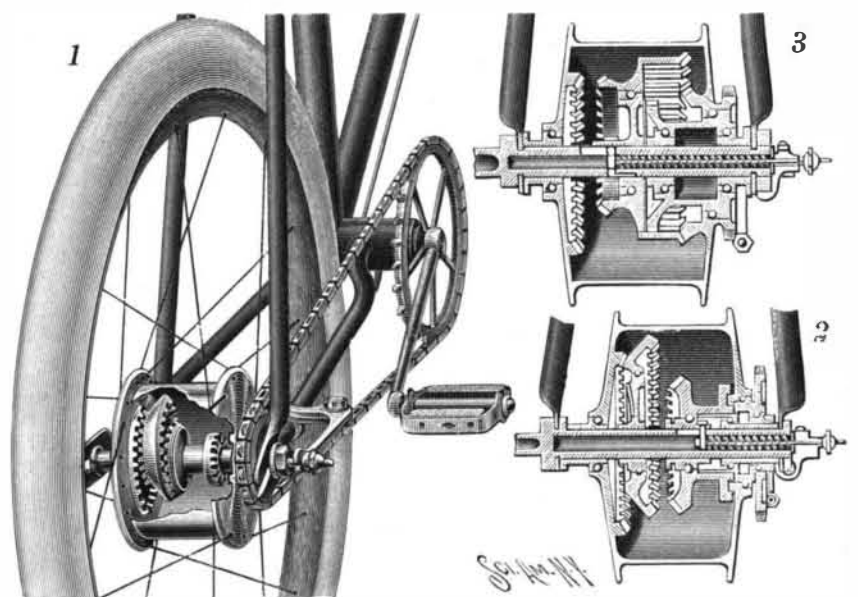

BALLOCH'S DIFFERENTIAL BICYCLE GEAR.

arrangement, there is obtained an invisible brake, which may be tightened to the desired degree at will through a slight turn of the grip without any fatigue to the bicyclist. A slight turn in the opposite direction at once loosens the brake either partially or totally.

The brush with which the brake block is provided has the effect of cleaning the pneumatic tire before it comes into contact with the rubbing part, thus sensibly reducing the wear of the tire.

We are indebted to La Nature for cuts and copy.