

Curious Error in a Trade Mark.

An amusing piece of ignorance is shown in the case of a trade mark recently issued for rye whisky. The proprietors of the trade mark have shown a greater knowledge of art than of history. The design represents, in martial attire, the bust of the unfortunate General Braddock. The hair is arranged artistically with the conventional queue, the bristling stock and the shimmering epaulets are elaborately displayed, but the specification describes the general as depicted in the uniform of an officer of the Continental army. General Braddock would surely be a little startled to learn that he had been deprived of his rank as an officer in the British army and had been adopted willy nilly into the American army. He would, however, be still more puzzled to know how he could be translated into the ranks of an army which did not exist until twenty years after his death. We advise our friends of the "still" to brush up their history and to turn the poor unfortunate back into his regulation red coat.

AN IMPROVED ROCK DRILL.

The illustration represents a head for rock drill cylinders in which the packing is placed at the base of the head, or close to its connection with the cylinder, whereby lateral pressure on the drill rod or piston rod will have no perceptible effect on the packing, thus preventing escape of the motive agent and prolonging the usefulness of the drill head. The improvement has been patented by Warren Wood, and is being introduced by the McKiernan Drill Company, of No. 120 Liberty Street, New York City. Fig. 1 shows the improved head connected with the cylinder, Fig. 2 being a sectional view. The head comprises a casing made in two separable sections secured together by transverse bolts, the casing sections having perforated lugs by which the head may be bolted to the drill cylinder, and within the bore of the casing is a bearing sleeve made of two longitudinally separated sections, one edge of each section having a projection engaging the edge of

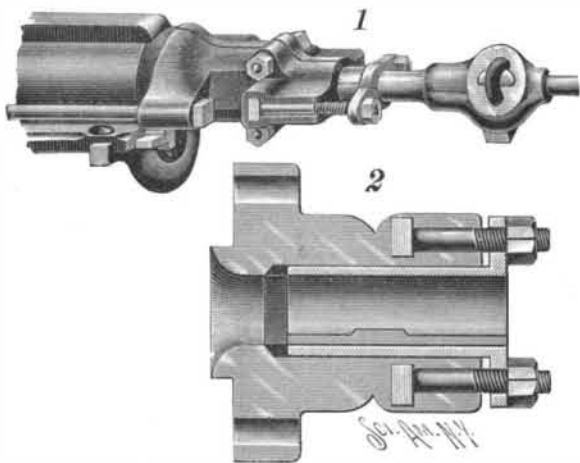

THE MCKIERNAN ROCK DRILL.

the other section. The joints between the sections of the casing and of the bearing sleeve respectively are out of line, to prevent any escape of the motive agent. The inner end of the sleeve rests on the packing and at the outer end of each sleeve section is a lateral perforated lug to receive tie bolts by which the sleeve may be forced tightly against the packing. When a drill works at an acute angle it is frequently the case that a new stuffing box or gland will have to be often supplied—a difficulty which this invention is designed to overcome.

Coal Production of the United States.

The compilation of the statistics of coal production in the United States in 1896, which has just been completed by Statistician E. W. Parker, of the United States Geological Survey, shows that the product in 1896 was 190,639,959 short tons, valued at \$195,557,649, against 193,117,530 short tons, valued at \$197,799,043, in 1895, a decrease of 2,477,571 short tons in amount and of \$2,241,394 in value. The decrease in product was entirely in that of Pennsylvania anthracite. The output of bituminous coal shows an increase of about one and three-quarters million tons. The anthracite product of Pennsylvania decreased nearly four and one-quarter million tons. It is a notable feature, however, that there was a decrease in the value of the bituminous product of over \$1,600,000, notwithstanding the increased output, and that there was a comparative increase in the value of anthracite, although, on account of the smaller production, it did not equal the value in 1895. The average price obtained for anthracite at the mines increased from \$1.41 in 1895 to \$1.51 in 1896. The average price for bituminous declined from 86 cents to 83 cents.

Among the important bituminous coal producing States, Pennsylvania, of course, stands first, with an output of nearly 50,000,000 tons. Illinois is an easy second with nearly 20,000,000 tons, or more than 75 per cent of the combined product of West Virginia and Ohio, which come third and fourth respectively. The race between Ohio and West Virginia was very close in

1896, there being but one thousand tons difference, and the output of each nearly 13,000,000 tons. These four States yield about 70 per cent of the total bituminous production.

Pennsylvania's bituminous product was a little more than one million tons less than in 1895. Ohio lost 480,000 tons. West Virginia increased her output about 1,500,000 tons and Illinois about 2,000,000 tons. The other important States showing increased production were Alabama, Arkansas, Colorado, Indian Territory, Kentucky, Maryland, and Texas, while Indiana, Iowa, Kansas, Missouri, Montana, New Mexico, Tennessee, Utah, Virginia, Washington, and Wyoming showed decreased production. West Virginia had the most important increase among the Appalachian States, Illinois in the Middle West, and Colorado was the only State in the Rocky Mountain region whose production increased.

The production by States is shown in the following table:

COAL PRODUCT OF UNITED STATES IN 1896 BY STATES.

States.	Total Production, Short Tons.	Total Value.
Alabama.....	5,745,617	\$5,171,055
Arkansas.....	669,374	743,577
California and Alaska.....	93,776	220,523
Colorado.....	3,139,078	3,630,632
Georgia and North Carolina.....	246,359	179,770
Illinois.....	19,786,626	15,809,736
Indiana.....	3,905,779	3,261,737
Indian Territory.....	1,366,646	1,918,115
Iowa.....	3,954,028	4,628,022
Kansas.....	2,764,801	3,175,032
Kentucky.....	3,183,478	2,496,806
Maryland.....	4,143,936	3,299,928
Michigan.....	92,882	150,631
Missouri.....	2,331,542	2,518,194
Montana.....	1,484,445	2,176,422
New Mexico.....	622,626	930,381
North Dakota.....	78,050	84,908
Ohio.....	12,875,202	10,253,461
Oregon.....	101,721	294,564
Pennsylvania—		
Bituminous.....	49,101,148	35,024,918
Anthracite.....	53,771,890	81,415,785
Tennessee.....	2,658,606	2,276,795
Texas.....	544,015	896,251
Utah.....	418,627	500,547
Virginia.....	1,254,723	848,851
Washington.....	1,195,504	2,396,078
West Virginia.....	12,875,202	8,336,685
Wyoming and Nebraska.....	2,233,184	2,918,225
Total.....	190,639,959	\$195,557,649

Effect on Bridges of Motive Power at High Speeds.

This subject, having been brought under the consideration of the Association of Railway Superintendents of Bridges and Buildings, was referred to a committee consisting of Messrs. George W. Andrews, J. E. Grenier, and Walter G. Berg, which made its report at the recent meeting of the association in Chicago. The report is published in the Canadian Engineer for December, and doubtless will be disappointing to some who were active in initiating the investigation, if a mere compilation of facts and experience previously gained by others can properly be called an investigation, says the Engineering Magazine.

In sum, the committee report that up to the present time no positive law of the mechanical action and resultant effects upon bridge structures of motive power at high speeds has been formulated, and that it is impossible to even approximately indicate the injurious effects of quickly moving loads on bridges.

The committee, in effect, confesses ignorance of the quantitative values of increased strains to which bridges are thus subjected. At the same time it expresses the full belief that these effects can be measured, and that instruments can be made that will register them. This assertion, however, is accompanied with the opinion that in so broad a field no one committee can ever arrive at conclusions of great value. These statements are made the justification for the compilation embodied in the report as a substitute for the original matter which, the committee seems to think, was expected, since it solicits the indulgence of the association for the deficiency. Classifying attempted determinations of impacts into (a) purely theoretical, (b) those directed to measurement of the stretch of bridge members during the passage of trains, and (c) those directed to the measurement of the deflections of bridge structures as a whole, the committee declares that the theoretical determinations have no interest to the association. Those in class b include tests practically limited to European investigations on riveted bridges, which have shown that impacts on such structures decrease, as spans increase, "in a rather uncertain and erratic manner," and that "the impacts in the various members of the same span are a vague function of the moving load required to cause maximum strain in the member considered."

The instrument invented by Prof. S. W. Robinson for accurately measuring center deflections is favorably spoken of as one means of obtaining accurate information in a general investigation of the subject. Members of the committee made about one hundred tests of the kind included in class b. The results are not included in the report, as they are said not to have

been "sufficiently positive." The report well indicates the present imperfect knowledge of effects of impacts of moving loads on bridges.

A CONVENIENT DRILL CASE.

A case in which to keep drills, so that it will always be easy to find just the drill wanted, is shown in the



THE WEISS DRILL CASE.

accompanying illustration. It is manufactured by Louis T. Weiss, Nos. 291 and 293 Graham Street, Brooklyn, N. Y. It has 60 round-bottomed receptacles, from No. 1 to No. 60, No. 1 holding sixteen and No. 60 about two hundred drills. On the raised edge opposite each receptacle is sunk a hardened and accurately ground bushing, forming a drill gage for that receptacle, as shown more plainly in the small figure, the size of each drill appearing in decimals opposite each bushing, and also the size of tap for which the drill is suited. One can see at a glance every drill in the case, and no time need be lost in hunting for a drill or drill gage. The case is made of cast iron, and the cover, when thrown down, will not slam, the hinge bar being a spring, and raising the cover at a touch of the finger.

IMPROVED BINDING FOR BLANK BOOKS.

A binding especially adapted for record books is shown in the accompanying illustration, the binding permitting the convenient removal and replacing of any of the leaves, for the making of entries by means of a typewriter instead of with pen and ink. A patent for the improvement has been issued to Edward M. Wallen (Mrs. Mary B. Wallen, administratrix), Box 43, New Decatur, Ala. Fig. 1 illustrates, in the broken away portion near the back of the cover, the application of the improvement. Embedded in the covers, near the point where they connect with the back, are plates, the top ones resting upon flanges at the bottom of tapering thimbles, and a chain passed through a flexible tube extends from each of the thimbles to an opening in the bottom plate, where it terminates in a head. At the upper end of each chain is a screw extension received by a screw-threaded plug, shown in Fig. 4, the plugs fitting the tapering thimbles, and Fig. 3 shows a plug without a handle, to be substituted

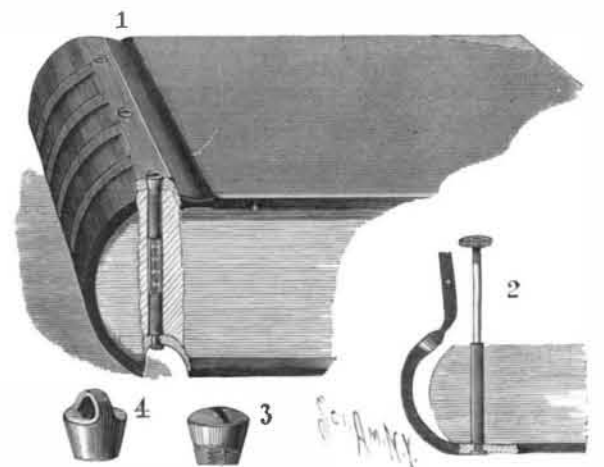

WALLEN'S IMPROVED BOOKBINDING.

for the other variety when the record is completed and the book is to be filed away. To remove a leaf, the plugs are removed, and the cover, with its thimbles, opened back, when rods are screwed on the threaded extensions of the chains, as shown in Fig. 2, the leaves being then passed upward on the rods until the leaf to be removed is obtained, the rods being detached and the plugs restored after the leaves have been returned to their normal position in the book.