

AN AUTOMATIC FEED HAND DRILL.

In the tool shown in the illustration the feeding of the drill spindle is automatically regulated, according to the nature of the metal being operated on, and a universal adjustment of the drilling tool is obtained. The improvement has been patented by James McSweeney, and is being introduced by the E. D. Jones & Sons Company, of Pittsfield, Mass. Fig. 1 represents the tool complete and Figs. 2, 3 and 4 are transverse

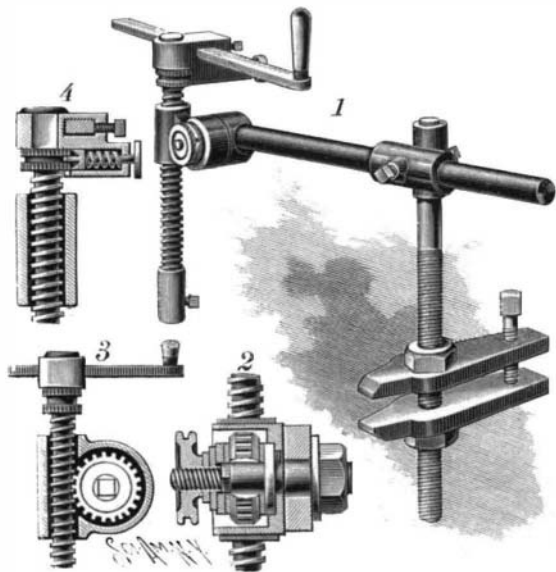

MCSWEENEY'S HAND DRILL.

sectional and side views. It is fastened to a table or other support by a suitable clamp, and has a threaded post engaging with its upper reduced end a collar forming part of a head having a second collar extending at right angles to receive a supporting rod, both the head and the rod being conveniently adjustable. On the outer end of the rod is a transverse bolt provided with a collar fitting into a recess of a casing, the bolt also having a lug engaging another recess preventing the casing from turning on the bolt, but permitting the latter with the casing to turn in the rod on slackening a nut. The casing has a bearing for a spindle having a drill socket at its lower end and handle at its upper end, the spindle being provided with a worm thread in mesh with a worm wheel turning loosely on the bolt within the casing, as indicated in Fig. 2. The inner and outer faces of the worm wheel abut against washers of fibrous wood or leather, which may be screwed up with more or less force to retard the turning of the worm wheel and insure a faster or slower turning of the tool-carrying spindle, which slides loosely in its bearing except as engaged by the worm wheel, the spindle turning it or rolling off on it, according to the resistance against the drill held in the socket or the retarding power of the worm wheel, owing to the action of the washers against its faces. The handle of the spindle is fitted with a casing, in which are adjusting devices, which may be arranged so that the operator, by turning the crank arm in one direction, can give a forward or a backward turning motion to the spindle, or by a forward movement of the crank arm will turn the spindle in one direction and by a rearward movement turn it in the opposite direction.

Shop Drawings.

It may appear as a curious fact, says Cassier's Magazine, that many men who have had years of experience in shops, and who are good workmen, seem to be afraid of drawings. While working to them with accuracy, and finishing their jobs satisfactorily, they never seem

quite at rest in regard to the meaning of their drawings, and frequently remark: "If I had another job of the same kind to do I could get through it in much less time." This means, practically, that if they had a model before them instead of a drawing they could turn out their work more easily. It raises the question, too, whether it would not pay to give more

attention to making drawings plain and to teaching the men to read them. Shading of parts and increasing the pictorial effect in general, so as to make one piece stand away from another, would seem to be a good thing, and in this respect some of the older forms of shop drawings might well be taken as examples worth following. To-day many of these out of date drawings are considered as having been wasteful of drawing office time, and uselessly elaborate, and yet they have good points. They told their story in a way quite foreign to the modern blue print.

Increased Use of Homing Pigeons.

The use of homing pigeons as messengers is said to have received considerable attention at the United States Naval Academy, at Annapolis, and, according to the New York Times, the government has recently established messenger pigeon stations at all the principal navy yards on the Atlantic and Pacific coasts, which have been organized as the result of satisfactory experiments made at the Naval Academy. Many newspapers use pigeons as messengers with decided advantage for the transmission of news, and so some of the recent election returns were brought in by carriers. Improvements in method and apparatus follow the new uses of the birds. The old way of attaching a quill with the message to the tail feather of the homer has been improved recently by an invention of Prof. Henri Marion, of the Naval Academy, a small water tight aluminum message holder, weighing less than eight grains, which can be fastened to the pigeon in an instant.

A TRACTION ENGINE BOILER EXPLOSION.

It is not often that one sees a more graphic picture of the rending effects of a boiler explosion than that shown in the accompanying cut. The excellent photograph of the remains of the traction engine—which latter, we are told, bore the name of Minnesota Chief—was taken by Mr. W. C. Gibbon, of Scotland, South Dakota, to whom also we are indebted for the particulars. The Minnesota Chief, which was a common farm traction engine, fell a victim to a foe which has laid low many a good traction engine before it—low water in the boiler. It seems that at the time of the accident the engine, which was on its way from one farm to another, became "stalled" in passing through a ravine. Presumably the engineer and fireman in charge tried to push their way through with the aid of an extra steam pressure, for, in response to the warning of a certain "mechanic and engineer" who "came to their aid and told them they would blow her up," the engineer "got on top of the boiler to open the safety valve." It was just at this critical moment that the boiler exploded, with the result that the engineer and fireman were blown to distances of 65 and 55 feet and instantly killed, the third party being blown to a distance of 30 feet and so badly scalded that he died three days later. The cylinder and steamchest were thrown 150 feet away, and will be noticed lying in the background of the pic-



A TRACTION ENGINE BOILER EXPLOSION.

ture; moreover, portions of the wreck were found fully a quarter of a mile distant. The driving wheels were wrenched off, the firebox blew out, nearly the whole of the cylindrical boiler shell stripped off, and altogether a more complete wreck was made than we remember to have seen in any previous locomotive or traction engine explosion.

be sprayed with a kerosene emulsion, which is made by dissolving two ounces of any good, hard soap in half a pint of boiling water, and adding to it a pint of kerosene, a little at a time and stirring continually. When you have a smooth emulsion, add two gallons and a half of warm water and mix well.—N. E. Lumberman.

AN IMPROVED WRENCH.

The illustration represents a wrench adapted for convenient adjustment with one hand, the movable jaw being quickly and firmly locked to the shank of the wrench at any desired point. The improvement has been patented by Lewis L. Hall, of Bourne, Oregon. Fig. 1 represents the tool complete, with a portion of the sleeve integral with the sliding jaw broken out, to show the engagement of a locking link with teeth on the under side of the shank, which is shown also in Fig. 2. The locking link has a rocking movement around the shank of the wrench, in suitable slots in a

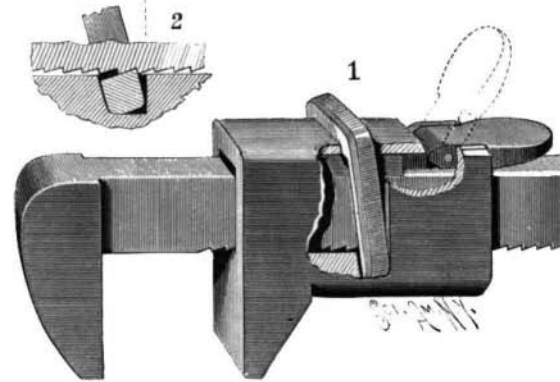

HALL'S WRENCH.

sleeve of the sliding jaw, and between the back of the shank and the sleeve is an adjusting bar, by the forward movement of which the locking link is given its locking position. The adjusting bar is moved by a lever pivoted near the rear end of the sleeve, and when the lever is carried upward, as shown in dotted lines, the sleeve and its connected jaw slide freely up and down the shank, but when the lever is parallel with the shank, as shown in full lines, the sleeve and jaw are firmly locked to the shank of the wrench.

The Most Expensive Product in the World.

As a matter of curiosity, says Consul Morris, of Ghent, November 12, 1896, I forward the following translation of a statement recently published in European newspapers showing the article which, it is claimed, sells at the highest price in the world:

What is the most expensive product of the world, inquires Mr. Wilfrid Fonvielle? He answers, It is charcoal thread (filament de charbon), which is employed for incandescent lamps. It is, for the most part, manufactured at Paris and comes from the hands of an artist who desires his name to remain unknown in order to better protect the secret of manufacture. It is by the gramme (15½ grains) that this product is sold at wholesale. In reducing its price to the basis of pounds, it is easily found that the filaments for lamps of 20 candles are worth \$8,000 per pound, and that for lamps of 30 candles they are worth \$12,000 per pound. The former have a diameter of twenty thousandths of 1 millimeter (1 millimeter = 0.0394 inch) and the latter four and one-half thousandths of a millimeter. The filaments for lamps of 3 candles are so light that it would require nearly 1,500,000 of them to weigh a pound. As the length of each of them is 10 centimeters (3.937 inches), their total length would be 187 miles.

A PROFESSIONAL gardener says that red spiders on plants are always a sign that the atmosphere is too dry, and to get rid of them the plants must be showered every day with water. The scales, however, that are found on many hard wood plants should be taken off with the finger nails, after which the plants should