

the bottom of the glacier, it is stratified with layers of clear ice.

Another kind of glacier front in this region is the sea wall of the valley tongue which is in rapid movement. This in places rises one or two hundred feet above the water, and extends to depths several times as great beneath it. As seen from the fjord it is a wall of marble whiteness, absolutely free from all impurities. Whatever rock debris the ice is carrying into the sea it is transporting below the water level. The top of this ice front is extremely irregular, partly by the cracking along the crevasses and partly by the action of melting. It is so irregular that travel over the end of the glacier is an impossibility.

In the front of the ice one sees numerous cracks, and the whole mass has an extremely unstable position. That this cracking does really represent instability is every now and then plainly proved, by the reports that proceed from the ice front, and by the fragments which one may see drop from its top and sides. Along the front of a large glacier there is a constant shower of these ice fragments, and the sea near by is littered with the bits of the glacier that have thus fallen into the sea.

Not only are fragments thus broken off by the melting and cracking above the water, but the ice is made unstable by the action of the waves at the shore line. When the tide is low one may see extensive undercut cliffs and sea caves of ice, which add distinctly to the instability of the ice cliff. This loss from the glacier front partly balances the advance, but not entirely. As one watches the front of one of the Greenland glaciers, every once in a while he sees a great block, hundreds of yards in length, crack off from the ice front and float away. Sometimes this ice breaks off from the glacier without producing much commotion, but much more frequently the masses of ice fall forward as they break off, and stir up the water, producing waves whose effects are felt miles away. The reason for the breaking off of these large bergs is the advance of the glacier into the fjord so far that the buoyancy of the water lifts and cracks it.

Hence the glacier which covers so large an area of Greenland advances outward until it is either destroyed by melting along the land margin or until it reaches some place in the sea where it breaks off and floats away. So long as the supply and these causes for the destruction of the glacier exactly counterbalance one another, the front of the glacier will remain permanently in one position; but if the supply exceeds, then the front of the glacier must advance upon the land and extend farther out into the sea; but, on the other hand, if the causes of destruction exceed the supply, the front of the ice must withdraw. This withdrawal may be accounted for either by a decrease in the supply of snow or a change in the climate, which causes an increased melting.

Studies along the margin of Greenland show that land now bare has within very recent geological times been encompassed by ice. In that part of Greenland near latitude 74°, where my studies were carried on, I found proof that the glacier has reached at least thirty miles further, covering all the land, some of which reaches nearly three thousand feet above the sea level. This means a very much greater extent of ice than the present. Even now the glacier is in process of retreat, and moraines that were evidently built at the base of the ice are now at some distance from it. Some of these moraines have been left by the ice so recently that no vegetation whatever, not even lichens, has found time to develop on the rock. Therefore, even at present the Greenland glacier is engaged in a withdrawal from the land, and this has been in progress for some time and has succeeded in uncovering a part of the margin of Greenland. How far this will go, and whether Greenland may again become the seat of a temperate climate and the site of a temperate flora, as it was before the glacial period, no one can even estimate.

Cornell University.

#### A FIRE ESCAPE AND WATER TOWER.

The illustration represents an improved fire department apparatus by which a platform may be readily raised and lowered to make connection with windows, enabling the firemen to enter the upper stories of a building for rescuing persons and facilitating the throwing of streams of water where desired in a burning structure. The improvement has been patented by Michael W. Hennessey, of No. 203 Sands Street, Brooklyn, N. Y., the inventor being chief machinist on the United States cruiser Columbia. On the truck is a platform frame, and means are provided for readily swinging the platform into level position when the truck stands on uneven ground. On the platform are two pairs of connected lazy tongs, the lower members of which on one side are pivotally connected with a stationary bracket, while the other lowermost members are pivotally connected with a cross piece sliding in bearings and formed with screw nuts in which screws a longitudinal screw rod. The outer end of this rod carries a hand wheel, by turning which the cross piece is moved forward or backward by the screw rod, closing or opening the lazy tongs. The uppermost members of

the lazy tongs on one side are pivoted to a platform to be raised, and the corresponding members on the other side carry rollers which loosely engage the under surface of the platform, the latter having posts and chains forming a railing on its sides and ends. On the platform is a turntable which may be turned to and locked in any position by removing and inserting a pin. On an extended portion of the turntable is pivoted a ladder, connected near its outer end to a yoke from which a rope passes over a pulley at the top of a post on the turntable and thence to a windlass, by means of which the ladder may be placed at any desired angle to connect the turntable and platform with the window of a building, the ladder preferably being made with extension sections, and its position as extended being indicated by the dotted lines. On the front of the truck platform

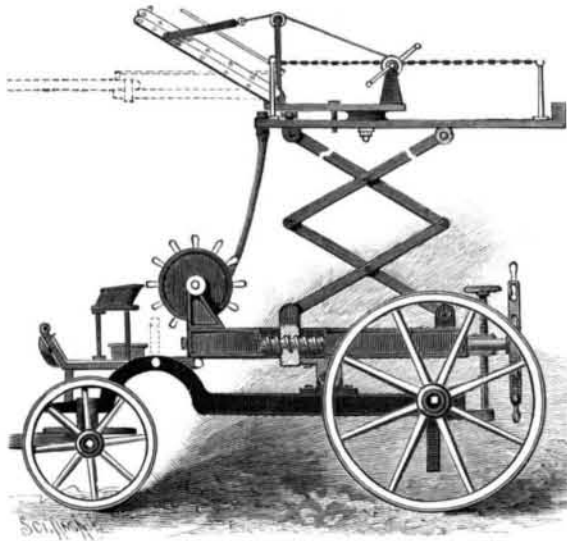

HENNESSEY'S FIRE ESCAPE AND WATER TOWER.

frame is a reel, one end of the shaft of which is hollow and adapted for connection with a water pipe, the inner end of the shaft being connected with a hose wound on the reel, and the outer end of the hose being connected with a threaded pipe in the platform raised by the lazy tongs, the latter pipe being adapted to receive a hose nozzle for the use of the firemen. The lazy tongs, when in extended position, are preferably steadied by guy rods or ropes leading to the ground.

#### BATCHELOR'S RIPPING ATTACHMENT FOR SEWING MACHINES.

The illustration represents a simple device readily attachable to a sewing machine table and operated by a lever connected with the needle bar for rapidly ripping seams or cutting material. It was patented in July last by Francis M. Batchelor, of Portland, Oregon, and, as will be seen by the accompanying letter, this inventor has sold his patent for a handsome sum of money. The following letter speaks for itself:

American Steel Company,  
Portland, Oregon, March 6, 1897.

Messrs. Munn & Company.

Gentlemen: I am pleased to advise you that I have just sold my United States patent, No. 569,827, which you obtained for me on the 28th of last July, for \$50,000 spot cash.

If it will do you any good or be of any interest to your readers, you are at liberty to use this information in any of your several publications.

Very truly yours,

F. M. BATCHELOR.

Fig. 1 is a sectional side view and Fig. 2 is a plan view of the improvement, the knife, A, sliding in a

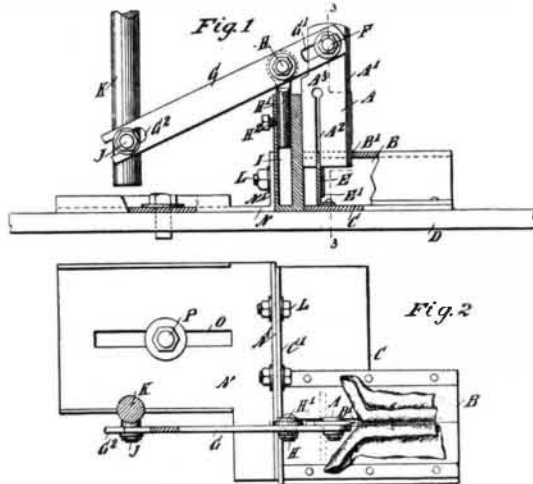

SEWING MACHINE RIPPER—A \$50,000 INVENTION.

in the apex of a peak-shaped rest, B, secured on a table, C, resting on a sewing machine table, D. The material to be ripped or cut is advanced on the apex of the rest against the cutting edge of the reciprocating knife. The latter is guided in its up and down movement by a guide, E, engaging a vertical slot, A', in the blade, and in the upper end of the knife is a pivot, F, engaging a

slot in a lever, G, fulcrumed and held vertically adjustable at the upper end of a post, H. The outer end of the lever has an elongated slot engaging a stud, J, secured on the needle bar, K. The table carrying the ripping attachment may be readily adjusted and secured in proper position on the sewing machine table.

We desire to congratulate Mr. Batchelor upon the success he has attained with his patent. His letter was sent to us without any solicitation on our part.

#### The Hippocratic Oath.

A correspondent of the Medical Record seeks information regarding the Hippocratic oath, taken by physicians upon graduation.

He states that he has inquired as to the substance of this oath of many physicians, who have been unable to give him a satisfactory answer. It is highly probable that but a few of our best educated physicians ever knew the text of the oath they were taking. The Medical Record gives the following translation of the oath in full:

"I swear by Apollo the physician, and Æsculapius, and Health, and All-heal, and all the gods and goddesses, that, according to my ability and judgment, I will keep this oath and this stipulation—to reckon him who taught me this Art equally dear to me as my parents, to share my substance with him, and relieve his necessities if required; to look upon his offspring on the same footing as my own brothers, to teach them this art, if they should wish to learn it, without fee or stipulation; and by precept, lecture, and every mode of instruction, I will impart the knowledge of the Art to my sons, and those of my teachers, and to disciples bound by stipulation and oath according to the law of medicine, but to none others. I will follow that system of regimen, according to my ability and judgment, I consider for the benefit of my patients, and abstain from whatever is deleterious and mischievous. I will give no deadly medicine to any one if asked, nor suggest any such council; and in like manner I will not give to a woman a pessary to produce abortion. With purity and with holiness I will pass my life and practice my Art. I will not cut persons laboring under the stone, but will leave this to be done by men who are practitioners of this work. Into whatever houses I enter, I will go into them for the benefit of the sick, and will abstain from every voluntary act of mischief and corruption, and, further, from the seduction of females or males, of freemen and slaves. Whatever in connection with my professional practice or not in connection with I see or hear, in the life of men, which ought not to be spoken of abroad, I will not divulge, as reckoning that all such should be kept secret. While I continue to keep this Oath unviolated, may it be granted to me to enjoy life and the practice of the Art, respected by all men, in all times. But, should I trespass and violate this Oath, may the reverse be my lot."

#### Laws of Teaching.

1. There is no school unless the father, the mother, the teacher, and the pupil keep school together.
2. Know thoroughly the subject to be taught and explain to the pupil why you teach it.
3. Gain and keep the attention of the pupils. Excite their interest.
4. In your teaching use language that your pupils understand.
5. Begin with the known and go by easy steps to the unknown. Take the whole class with you!
6. Excite self-activity in the pupils and lead each to discover truth. Show the class how to study.
7. In each lesson let a halt be made and then have pupils fix points already made, the conclusions reached, and the premises upon which the conclusion is based.
8. The teaching must touch the whole nature of the child and stimulate to higher action and more industrious habits of work, of silence, of obedience, honesty and truthfulness. Three-fourths of education is a habit of work.—J. M. Greenwood in Midland Schools.

#### A Quick Piece of Work.

One of the quickest pieces of work on record in the way of installing a ventilating plant was recently completed at Harrisburg, Pa., says the Engineering Record. It may be remembered that the building containing the assembly rooms of the Senate and House of Representatives at the State Capitol was destroyed by fire on February 2. An unoccupied church was temporarily secured, but this building being without a suitable heating plant or any ventilation whatever, it was necessary to install a new plant before the building could be occupied. Accordingly, an order was telegraphed on February 4 to a blower company, instructing them to ship two 6,000 foot coils with 60 inch fans as soon as possible. One apparatus was placed on board the cars within twelve hours and the duplicate within thirty hours from the receipt of the order. In the meantime, a large force of men was at work on the ground, putting in the foundations, steam mains, and air piping required for the apparatus. The heating plants were completed and the building ready for occupancy within one week from the date of the fire.