

## Correspondence.

## The Lilac Borer.

To the Editor of the SCIENTIFIC AMERICAN:

Kindly inform me what the specimen is sent by me in a separate package marked borer in lilac bush.

This fellow, or one of his near relatives, seems to be destroying every kind of shrub and tree around my summer residence. Some branches of trees, and very large ones at that, have been sawn through, as it were, and completely destroyed.

The one sent you was taken from the center of a lilac bush's branch. Now the main thing is: What to do to kill this pest and destroyer of trees and shrubs.

You will confer a great boon on me and the people in this vicinity by informing me about this borer and his destruction.

H. J. DOLL.

Buffalo, N. Y.

## ANSWER BY PROF. C. V. RILEY.

The whitish worm, with light brown head, three pairs of short horny legs on the thoracic segments beneath and five pairs of membranous prolegs, one pair each on the sixth, seventh, eighth, ninth, and last segments of the body, sent by Mr. H. J. Doll, of Buffalo, N. Y., is the lilac borer, larva of *Podosesia syringæ* (Harr.) This is one of the *Ægeria* moths, which in general appearance and in flight recalls one of the paper wasps belonging to the genus *Polistes*. The wings are narrow, the front pair smoky brown, the hind pair transparent between the veins, and the legs long and banded with yellow and black. The female lays her eggs in patches on rough or knotty places on the bark of lilac or ash, and on branches generally from one to three inches in diameter. Sometimes, however, the larva is found in the main trunk or in branches of seven inches and upward. The egg hatches in about six days and the larva at once eats through the bark into the solid wood. The larva pupates in May in a slight cocoon, after cutting a passageway to the bark, leaving only the thin outer covering thereof, and the moth issues some three weeks later, the chrysalis having pushed its way partially out of the bark to facilitate the emergence of the moth, as is the habit of other members of the family.

The work of this particular insect is confined to the lilac and ash, and my own experience in Washington and elsewhere would indicate that it is even more troublesome to the ash than to the lilac. There are also in this latitude two generations annually, so that I have known young ash trees that were growing vigorously in spring to be entirely riddled and killed during a single year.

Your correspondent is mistaken in attributing the injury to other kinds of shrubs to the work of this particular species, and the probabilities are that the trunks and branches of other trees which have been sawn through as he describes are affected by some other insect, of which almost every tree and shrub has its own particular species. There are, in fact, so many that it would be useless to offer suggestions without more definite and specific information, though the probabilities are that he is troubled by the larva of the leopard moth (*Zeuzera pyri*), a comparatively recent introduction from Europe, but a species which has multiplied exceedingly and has proved very destructive, especially in New York State.

The lilac borer is not easy to deal with, and the best preventive that I can suggest is to prune the bushes down well and then paint the branches with a mixture of air-slaked lime and Paris green, in the proportion of 1 part of the green to 15 or 20 of the lime. This should be done early in May and repeated later if heavy rains wash off the mixture. The parent moth will probably avoid such trees or shrubs, but if she should oviposit on the limbs thus treated, the newly hatched larva will perish in endeavoring to eat into the wood.

## The Tiger Swallow-tail.

The smooth caterpillar, of a greenish color, characterized by a continuous black transverse band bordered with yellow across the fourth segment dorsally and by having a pair of small eye-like spots, one on each side of the second segment, sent by Mr. H. S. Burroughs, of Silver Bay, Lake George, is the larva of one of our prettiest swallow-tailed butterflies (*Papilio turnus*). It is known as the tiger swallow-tail, because the color of the butterfly in its commonest form is yellow, with black transverse bands. This larva feeds on a number of different plants and particularly on plum, cherry, lirioidendron or tulip tree, birch, poplar, magnolia, linden, pear, ash, catalpa, hop, beech, alder, hickory, willow, lilac, etc. The lilac is given as its favorite food in the North by Mr. S. H. Scudder, who is one of our best authorities on the New England butterflies. The eggs are globular and yellow and laid on the under side of the leaf. The chrysalis is pale yellowish gray, inclining to brown, and is characterized, as are most of the chrysalides of the genus, by a medio-dorsal prominence on the thorax and by two ear-like projections on the head. It is attached by the tip of the body to a

little bundle of silk and suspended around the waist, so to speak, by a thread of silk.

An interesting fact in connection with this butterfly is that in the Southern States, more particularly, but reaching as far north as New York and Wisconsin, a dimorphic form occurs in which the yellow of the wings is replaced by a dull black, this variety being known as *glaucus* Linn., and confined to the female sex. The caterpillar rarely occurs in sufficient numbers to be injurious.—C. V. R.

## PHOTOGRAPHY OF THE RETINA.

This apparently impossible feat has been performed several times, having been first accomplished in 1893 by M. Londe, a member of the French Société de Photographie. We translate from Gaea, Leipsic, May, an account of an improved method used with great success by Drs. Grebe, of Cassel, and Greeff, of Berlin.

"The eye to be photographed, A (see illustration), is furnished with a water cell, W, according to Gerloff's system, to avoid reflection from the cornea. Before it a clean plate of glass, S, is so placed that the rays from a source of light of the desired intensity can be thrown by it into the eye. At P is a sensitive plate that is sheltered from outer light by means of a box, K. The box can be closed by a pneumatic shutter, V. On the plate, P, are cross lines which, when the plate is illuminated by the red lantern, L, can be seen by the eye.

"The feat is performed in the following manner: The eye is brought to perfect rest by means of a head support. Then the glass plate is so turned that a provisional point of light above appears to lie in the middle of the shutter, V. Then in perfect darkness the shutter, V, is opened and the eye is focused on the cross wires of the red-illuminated plate. Everything is now ready for the photography, which is accomplished by flash light.

"The procedure can be understood without further explanation. With a minimum of light quite a large picture may be taken directly; the focusing is the

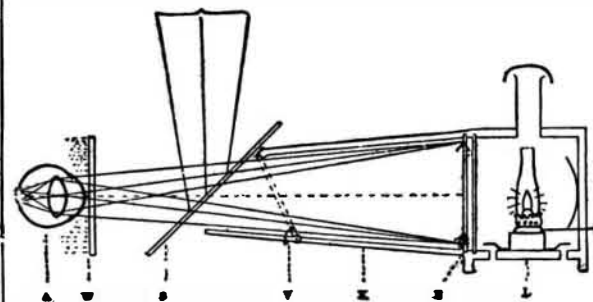

sharpest imaginable, because it is done with the eye itself. The smaller the picture, the sharper will be the outlines. Near-sighted eyes are very good for photographing."—Literary Digest.

## Cycle Notes.

A. Mercati, secretary of the Hellenic Committee of the International Olympic Games, which will be revived at Athens April 5 to 15, 1896, announces that the management will provide four international bicycle races, which will be run on a new track, which is to be built for the purpose. The programme of the races is as follows: There will be a 2,000, a 10,000 meter, a 100 kilometer, and a 12 hour race. The two former races will be without pacemakers and the last two with pacemakers. The rules of the International Cyclists' Association will govern the contest.

The volunteer service, or militia, of Great Britain includes about 7,000 bicyclists. For several years the signal corps of the Connecticut militia has been equipped with bicycles. In Belgium the bicycle is utilized for the quick moving of troops. General Nelson A. Miles recognized nearly a year ago that in the next great war the bicycle will become a most important machine for military purposes.

Something new in the way of a bicycle trip is claimed for the journey made by four riders near Virginia City, Nevada, recently. They started in at the mouth of the Sutro Tunnel on two tandems and rode through the tunnel to the shaft station on the 1,750 foot level of the Consolidated California and Virginia Mine, a distance under ground of 4½ miles.

Bicyclists in Hillsdale County, Mich., have found a new diversion in chasing woodchucks over the prairies on their wheels and running them down. Given a fair distance to run before striking cover, the bicyclist usually wins and gets the woodchuck.

To clean the bicycle chain, remove it from the machine and soak it in turpentine for several hours, then clean it with a brush, as an old tooth brush, link by link, and after this dip it in clean kerosene oil and dry thoroughly with cheesecloth. See that both sprocket wheels are thoroughly cleaned and then replace the chain. Do not use oil on the chain, as it produces a clicking sound. Use graphite or any of the various chain lubricators now on the market.

The best way to clean the bearings of a wheel is to take them out and then remove all dirt and rust from them. Kerosene may be used to remove the gritty

substances from the bearings. The kerosene should be poured into the oil well, the wheel being kept revolving constantly. Old clothes should be worn at this job, as the kerosene is likely to splash them. The cleansing fluid can best be poured into the bearings by the aid of an ordinary oil can. Lubricating oil should be run in after the kerosene has been drained off.

An electric bicycle lamp is now being introduced into New York City. The lamp is provided with a current from a storage battery, which furnishes sufficient current to actuate the lamp for about twenty hours. The total weight of the battery and lamp is about 2½ pounds. The battery can be recharged at authorized agents' stores for ten cents each.

A fair estimate of the bicycle output of 1895 would be 350,000 wheels of all kinds.

A twenty-four hour bicycle contest at the Herne Hill track ended July 27. The winner, Mr. Hunt, covered 458 miles and 1,459 yards, and Mr. Bennett 447 miles 75 yards. Fifteen men started, but only four finished.

A middle-aged woman in an old wrapper and sun-bonnet was an odd figure as she rode her bicycle to her neighbor's along a Connecticut road recently. The keeping of a horse is no longer an absolute necessity to life far from a railroad station.

A milkman of Wissahickon, Pa., uses a bicycle in serving his early morning customers. He has invented a little rig for strapping a milk can safely to the machine. Tricycles have been used a long time by milkmen, especially in England; but this is probably the first instance of the rather unstable bicycle being used for this purpose.

The bicycle is being put to practical use in Philadelphia. In addition to policemen being mounted on wheels, the messenger boys in the outlying districts have been provided with bicycles and the service rendered is very efficient, as calls can be answered in less than one-half the time it has previously taken.

An interesting bicycle will shortly be placed on exhibition. It was made by a South American mechanic from a pattern of a wheel which he saw in a magazine. In three weeks this native blacksmith completed a bicycle of a safety pattern which weighs 32 pounds. The whole machine is made in the best possible manner. The tires are made of leather tubes filled with hair and are as easy riding as cushion tires. This is the first wheel ever built in South America by a man who never saw a bicycle.

"The use of the bicycle has expanded and developed from a salutary athletic exercise into a great social obsession. It has seized upon every class of society, both sexes, all ages, and every condition of life. It is taken up by the well because it makes them feel better, by the invalid because it makes them feel well, by tired people because it rests them, and by the rested because it makes them feel tired. The fat ride to get thin and the thin to get fat. It has displaced the horse. It has made the simple and ancient custom of walking most unpopular; it has cut down the function of the steam car and competes successfully with the suburban trolley. The doctors have taken it up and expressed their approval of it, and we are far from saying a word in opposition. The bicycle has come to stay, though not with quite the omnipresent activity which it now enjoys. Already we notice grave and reverend seigniors in our profession riding along the cobble stones in their golf suits instead of lying comfortably back in their victorias. Time that used to be spent in serious scientific pursuits at the hospital, in the laboratory, and at the desk is now shortened in order to enjoy a ride up the Boulevard. The bicycle has cut down the scientific activity of the New York profession at least fifty per cent already."—The Post Graduate.

## A Tale of Co-operation.

A coal mine at Monthieux, near St. Etienne, in the Department of the Loire, was abandoned by its owners several years ago because it could no longer be worked at a profit. The discharged miners, finding themselves without work, formed a co-operative concern and obtained a title to the abandoned mine. They then set to work, and by opening new veins, by observing strict economy and unflagging industry, made the mine pay. Now note the result. The mine workers in the neighborhood, engaged with their employers in an eternal wrangle over wages, sought, and in many cases secured, employment in the co-operative concern. The founders of the latter, however, would not admit the newcomers on equal terms with themselves. When it came to the question of wages, for instance, they would not pay the new men the same rates that were paid to the men who by extraordinary efforts had turned a worthless hole in the ground into a paying piece of property. When the new miners resisted and created a disturbance, the aid of the police was invoked and the disappointed element was dispersed. No doubt they looked upon themselves as the victims of capital and the slaves of a mushroom bourgeoisie. To an outsider it only illustrates that thrift, industry, and perseverance lead to success, and that men exhibiting these qualities are not likely, whether wage-earners or capitalists, to allow shiftlessness and indolence to run away with the fruits of their labors.—N. Y. Tribune.