

The La Grange Dam.

Stanislaus County, Cal., will soon have the highest overflow dam in the world.

It is called the La Grange dam, and is being constructed for the Modesto and Turlock Irrigation Districts. Its location is in the canyon of the Tuolumne River, three miles from the town of La Grange. Work on the project was commenced in June, 1891, and has been prosecuted continuously ever since. A force of 200 men has been employed on the work, the total cost of which will be \$600,000.

The annals of engineering have hitherto recorded as the highest the Vyrnwy dam, which retains the water supply for the city of Liverpool, England. Its height, from base to summit, is 127 feet, but the La Grange will be two feet higher. Other celebrated dams, such as the Bear Valley, in San Bernardino County, and the Sweetwater, near San Diego, are properly known as reservoirs, and the protection of their basins as retaining walls.

The La Grange is being built by R. W. Gorrill, and will be 360 feet long on top, the plan being curved on a radius of 320 feet. Its maximum height above the foundation will be 127 feet 9 inches. The front face of the wall is made to conform to the curve described by the water in overflowing, and to deflect it into the basin in front of the dam.

The dam is built of "cyclopean rubble," and is a model of solidity. Huge rocks, weighing from six to ten tons, were first laid on the bottom. All their projecting pieces were cut off, and a flat but rough surface was prepared for the lower bed. Before being placed in the bottom, all stones, whatever their size, were scrubbed, and subjected to the action of numerous jets of water under pressure of seventy-five feet.

The process of construction was as follows:

"A level bed was first prepared in the rock and covered with a two-inch layer of cement mortar, which was beaten to free it of air. A large stone was then lowered into position by a steam crane, and was beaten down into the mortar by blows from heavy handmauls. Other large stones were similarly placed, but so as not to touch each other. The spaces left between them were filled with concrete, which was thrust into the narrow spaces with tampers.

"The work within the reach of each crane was brought up from six to eight feet before the crane was moved. In each course the immense stones were laid so as to bind with those in the course below. No horizontal joints passed through the wall, as the top of each course was left with projecting stones and hollows, which permit it to be well bound with the next course. To make the back face thoroughly water-tight, the vertical joints were filled with mortar alone, and into this broken stone was forced."

The La Grange dam will distribute water over a territory embracing 276,000 acres. The Turlock district comprises about 198,000, and the Modesto district 78,000 acres. The water will flow over the dam into two ditches. One will be 30 miles long and 100 feet wide, the other 28 miles long and 80 feet wide. The waters of the Tuolumne River will be banked up by the dam in the rocky canyon. A lake will thus be formed four miles long and a half mile wide. An idea of the solidity of the dam may be gathered from the fact that at its base it is 117 feet 9 inches thick, and that of solid stone, forming an indestructible barrier to the lake of water behind.—*Pacific Lumberman*.

Rapid Building.

Chicago has made a new record for rapid building operations by the manner in which work has been pushed on the New York Life Insurance Company's building, now in course of erection at La Salle and Monroe Streets. This building is of the so-called Chicago construction. On July 19 excavation was commenced, and as there had been no cellar under the structure which had previously occupied the site and been torn down, the work was from the surface. In nine days the curb wall was completed. On August 17 the entire foundation had been laid, and on the day following the first iron column was set in the basement. Thirty-six working days thereafter—September 28—a flag waved from the top, announcing the entire completion of the iron framework, and five of the days had been lost in waiting for delayed iron. On October 5, besides the skeleton framework, two stories of granite and three of terra cotta exterior walls had been laid, four floor arches of fireproofing had been set in place, the entire system of steam mains throughout the building set, and the basement floor laid in concrete. Ten days were consumed waiting for cut stone. Thus in ten weeks and one day—sixty-one working days—the entire framework for a building twelve stories in height and covering an area of 80 by 140 feet had been set, and a week later five stories of outer wall, composed of granite and terra cotta, had been laid. For four weeks double relays of men were employed, sixteen hours being counted a day; for the remainder of the time eight hours constituted a day's work. Taking this into account, the work occupied ninety-five working days from the day on which the

first dirt was removed from the site. It is expected to have the structure ready for occupancy by February 1, 1894.

A SIMPLE GAS METER CONNECTION.

To save time in setting meters, and afford an efficient and inexpensive connection with the street service pipe and also with the distributing gas pipes in a house, is the design of this improvement, which has been patented by Mr. Albert H. Gindele, of No. 228 Second Street, Jersey City, N. J. On the end of the lead pipe to be connected to a meter is placed an exteriorly threaded sleeve, and the end of the pipe is then upset to form a flange against which the sleeve abuts. A cylindrical junction nut, preferably of brass, screws upon the threaded sleeve, and has a hub-like extension which bears against the flange and also screws upon a thimble screwing into the bore of the lead pipe, the

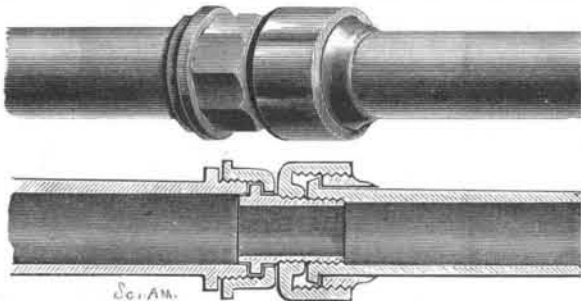
**GINDELE'S GAS METER CONNECTION.**

thread of the thimble producing a mating thread in the soft metal of the pipe. The thimble also has an external flange which is engaged by and has gas-tight contact with an inwardly radial flange on a union nut of the usual form, the nut screwing upon the end portion of the hollow meter post. The improvement is designed to afford a simple and reliable connection and dispense with solder joints.

SECURING PROPELLER BLADES TO THE HUB.

The illustration represents an improved means of securing propeller blades to the hub, recently patented by Mr. Martin Davies, Jersey City, N. J.

According to this improvement, screw bolts are inserted through the hub from the inner side, and then through the bases of the propeller blades, when nuts are applied to their projecting outer ends. Fig. 1 is a view in perspective; Fig. 2 a horizontal section at one side of the hub; and Fig. 3 is a section through the hub and opposing blades, the heads of the bolts being countersunk in the interior of the radially bored hub and arranged to form part of a smooth hub bearing for the propeller shaft. The hub has four faces, each adapted to receive a propeller blade, and having a circular recess in one wall of which is a feather, the base of each blade having a boss entering the recess, and

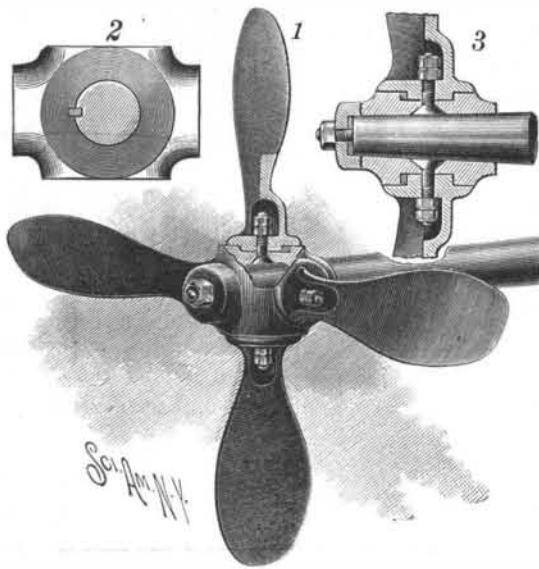
**DAVIES' PROPELLER.**

the boss having a recess to receive the feather. In securing the blade to the hub, the nut is turned down with great force, whereby the blade is securely clamped and fastened in place, but so that it may be removed with convenience and dispatch. This invention has been practically tested in actual use, and its value has thus been demonstrated.

THERE is a bill pending in Congress providing for the issuing of postal fractional currency, in denominations of 5, 10, 25 and 50 cents. This is intended to furnish the public with a convenient form of money for transmission through the mails. It is to displace the postal notes, which are to be withdrawn from sale on January 1, 1894. This fractional postal currency would be furnished at its face value and without the formality now necessary to get a postal note. There are branches of business involving small transactions which would be sensibly aided by such a currency for inclosure in letters.—*Philadelphia Ledger*.

A Steam Carriage for Road Use.

C. L. Simonds, of Lynn, Mass., has made a steam carriage for his own use that will make ten miles an hour. The carriage weighs only 400 pounds and can carry two persons at a time. It has the appearance of an ordinary carriage in front, except there are no provisions made for a horse. The wheels are of cycle make and are four in number. The hind wheels are 43 inches and the front wheels are 36 inches, with rubber tires. The boiler and engine set just in the rear of the seat and give the carriage the appearance of a fire engine. The steam generates in what is called a porcupine boiler, which weighs 100 pounds. The steam is made by naphtha flames from three jets. The naphtha is kept in a cylinder, enough to last for seven hours, and there is a water tank that will hold 10 gallons. There is a pump that is automatic in action directly connected with the engine. The steering part consists of a crank wheel on the footboard, so that the engineer can steer and attend to the engine at the same time. The body of the carriage rests on a cradle and three springs. It is easy riding, and allowance has been made for every movement. The shafts are of steel, and can stand all of 1,000 pounds. Mr. Simonds has given the steam carriage a trial already, and it has proved a success. It started off at a ten-mile gait; there was no noise, smoke or trouble whatever.—*Springfield Republican*.

Photographic Notes.

Photographing upon Fabrics.—Mr. August Villain, a dyer of Aubervilliers, recently communicated to the Societe d'Encouragement the processes that he employs for obtaining photographic prints upon fabrics. He recalled the researches of Messrs. Kopp, Willis, Green, Cross, and Bewan, and the application made by these chemists of alkaline bichromates, chromates of copper and aniline, solution of aniline in benzene, and denitrated primuline. In order to obtain the negatives, the process that has given Mr. Villain the best results consists in sensitizing the fabric with the following mixture:

Water.....	1,000 parts.
Bichromate of potash.....	35 "
" " ammonia.....	15 "
Metavanadate of ammonia.....	5 "

The fabrics impregnated with this solution are dried in the dark at a low temperature, and exposed to the light under a negative. They are afterward thoroughly washed. In this state they have fixed enough mordant to dye the print in baths prepared with the most varied artificial colors.—*Annales Industrielles*.

Photographing upon Marble.—In order to photograph upon marble there is applied to an unpolished slab of the latter a solution composed of:

Benzine.....	500 parts.
Spirits of turpentine.....	500 "
Asphalt.....	50 "
Yellow wax.....	5 "

After the solution is dry an exposure to the sun is made under a negative. The developing is effected with turpentine or benzene. The slab is then thoroughly washed, and those parts of it that are to remain white are covered with an alcoholic solution of gum lac. The slab is then immersed in a tincture of a coloring substance soluble in water.

After a short time the coloring material will have penetrated the pores of the stone, which is then removed from the bath and polished. The effects thus obtained are, it is said, very beautiful.—*Annales Industrielles*.

The Snow Sheds of the Union Pacific.

A correspondent of the N. Y. *Observer* says: "With two and sometimes three engines, our heavy train, now divided into two sections, climbed up the giant wall of the Sierra Nevada. We passed through the magnificent scenery of Shady Run, Blue Canyon and Giant and Emigrant Gaps. In running one hundred and seven miles we had climbed nearly seven thousand feet, sometimes over very steep grades. Before we reached the summit, snow sheds began to appear, and soon became practically continuous. It was the month of May, and the mountains were still covered deep with snow. We rode through forty miles of these wooden tunnels, from whose windows we could now and then catch glimpses of wild wastes of snow-covered mountains, and at other times of forests of pine and fir trees. Without these sheds it would be impossible to operate the road in winter. They are built in the most thorough manner, often upon solid foundations of masonry, and are separated by iron plates into sections, to guard against the spread of fire. There are automatic electric fire alarms in one of the longest sheds, and an engine with a tank close at hand is kept ready to flood any section that should catch on fire. The sheds are patrolled and guarded in a careful manner. Such attention is due not only to the passenger and freight traffic which the road conducts, but to the value of the sheds, which average from eight to twelve thousand dollars per mile. Several miles, where bridges and precipices made the construction difficult, cost as much as thirty thousand dollars per mile."