

**AN IMPROVED CAMERA LUCIDA.**

The camera lucida, that wonderful instrument invented by Wollaston in 1804, as well as the numerous improvements that have been introduced into it, still leaves much to be desired, in consequence of the disagreeable phenomenon of parallax that is produced in all the apparatus now in use. This phenomenon, which is due to the different distances that separate the eye from the object and the pencil, is completely suppressed in the new camera lucida of Commandant H. Blain. Moreover, it is always possible to proportion the light of the paper and that of the image that is projected upon its surface. It suffices to vary the in-



Fig. 2.—METHOD OF USING THE APPARATUS.

tensity of the light furnished by the silvered mirror, by placing a platinized mirror opposite it.

The hemerograph, for such is the name of the new instrument, is a very practical device that can be used without the least study. The drawing can be done without hesitation, the eye accommodates itself to all distances, and the point of the pencil and the image are always seen very distinctly.

The field of this apparatus is indefinite. It is used in a horizontal as well as in a vertical direction and at variable angles. It suffices to give a rotary motion to one of the mirrors that compose it in order to discover parts that remained invisible in a preceding position.

The hemerograph consists principally of two special mirrors of a perfect planimetry, arranged in a mounting of copper.

The upper, silvered mirror is provided in the center with an aperture that serves as a sight hole when the apparatus is placed horizontally. It is provided at

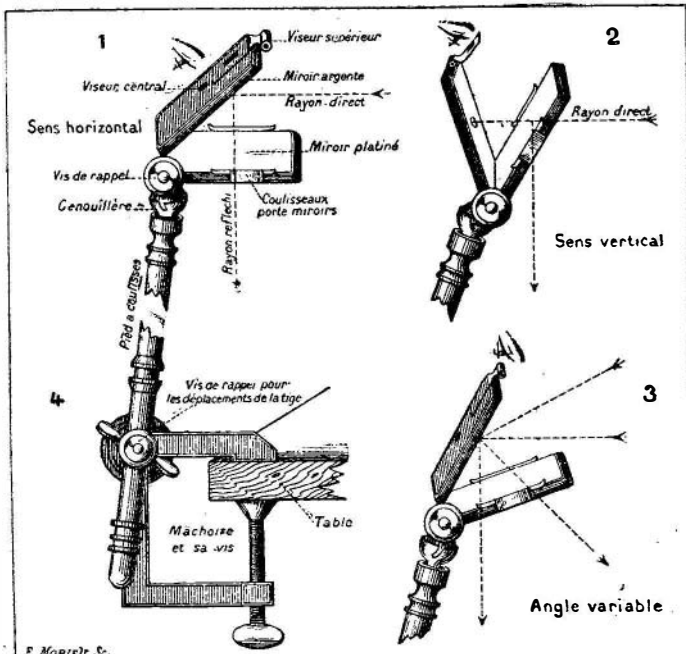

Fig. 1.—DETAILS OF BLAIN'S HEMEROGRAPH.

its upper part with a second sight hole designed to be employed in a vertical direction (Fig. 1).

The lower mirror, metalized with platinum, possesses a calculated transparency that permits of seeing the pencil and object always very distinctly and without any fatigue to the eye. This mirror is movable and may be replaced by a smoked one when work is being done in sunlight.

This apparatus is supported by an extensible foot provided with a joint that permits of its being raised or lowered according to circumstances, and of being turned in all directions.

Finally, if the instrument be placed before a telescope or a simple field glass, it will be possible to draw

on a large scale an object situated at a distance of several kilometers, according to the power of the spy glass, just as if it were placed at a few meters from the observer. This means will be able to render very great service to officers sent out upon a reconnaissance.

In order to place the instrument in position, as shown in Fig. 2, the jaws are fixed to a table, the extensible foot is adapted to it, and the mirror supports are installed upon the joint. By acting upon the binding screw, the foot is placed at the point desired, and the apparatus is ready to operate. It is necessary, then, to open the mirror supports, and when the foot is at the proper point to well expose the object, it is arrested by its adjusting screw. The instrument may be used with both eyes or one only. The play of the mirrors is so simple that after a first trial one will be master of the instrument.

Fig. 1 shows the method of using the instrument in the three directions: (1) horizontal; (2) vertical; and (3) at a variable angle. If it is used at a variable angle, the metalized mirror must be placed upon the lower edge of the cap of the spy glass, and the silvered mirror be brought to the angle most favorable for receiving the direct ray. The eye is placed as in the figure.

Enlargements can be obtained by interposing a convex lens between the apparatus and the objective, and, according to circumstances, between the apparatus and the paper. In order to obtain enlargements with a convex lens, the latter must be placed in the screw bolt fixed to the table, and brought to a focus by raising it or lowering it upon its slide, and the image or object be placed at about 15 centimeters behind.—*La Nature*.

**A RECENT IMPROVEMENT IN BUCKLES.**

The form of buckle shown in the illustration is designed to replace older varieties of buckles wherever a buckle is needed, and is particularly adapted to adjustably connect parts of harness for draught animals. It has been patented in the United States and Canada by Mr. George M. Aylsworth, of Collingwood, Canada, and a patent has been applied for in England. It is believed the new buckle will do away with the hand stitching now required to form an adjustable connection or joint between two or more pieces of leather, as these buckles are attached by means of rivets, and the tongue plate takes the place of the old form of keeper loop, as shown in Fig. 2. The frame of the buckle consists of a sheet metal blank secured to the strap by rivets, and with bent-upside flanges, in which, at one end, is a transverse pintle carrying a spring-pressed keeper plate. A tongue, formed of a rivet, is secured in the keeper plate, the tongue being adapted to pass through a strap and have a locking engagement with an opposite perforation in the web plate of the frame, as represented in Fig. 1, where the buckle is shown in use to make an ordinary joint. The buckle is convenient to adjust, and simple and cheap in construction, obviating the need of a keeper or loop on the strap to prevent the flapping of the end of the strap, and it is also very light, strong and neat in appearance. An affidavit of a practical harness manufacturer, familiar with the new buckle, sets forth that in his opinion a man will, with this buckle, make a set of harness in about half the time required with the old form of buckle.

**Library Mutilators.**

Among the notable institutions of New York is the Astor free library, where many thousands of volumes of the most important books, especially works of reference, are to be found. Any visitor may there consult a convenient index, call for the desired volume, and take a seat at a table. The work will shortly be brought to him by a polite attendant, and there he may sit and read for hours at a time. Most of the people who go to the Astor appreciate the benevolence of the founders of the institution and are careful to preserve the books intrusted to their temporary use. But there are some persons—two-legged skunks they might be called—who are mean enough to mutilate the books. They cut out and steal pages or parts of pages, which they are too indolent to copy, and manage to sneak out of the library undetected. One of the books in greatest demand is the "Scientific American Cyclopedia of Receipts, Notes and Queries." We are frequently asked by the librarian to replace such mutilated and missing pages. It is a pity that the book mutilators cannot be caught and punished.

**AN IMPROVED CAR AXLE BOX.**

The axle box shown in the illustration is provided with an improved sponge holder, has a novel spring closer for the lid of the box, and improved means to prevent the escape of oil from the box at its inner side. It has been patented by Messrs. William Rader and Edwin Hunter, Allentown, Pa. A center scroll on the lid is introduced between side scrolls in the box body,

detent disks with scalloped edges at the inner end walls of the side scrolls retaining the lid open or closed, by engagement of the notched edges with the body of a core rod secured in the scrolled end of a locking spring. The arrangement is such that the lid may be held at different points of open adjustment or in closed

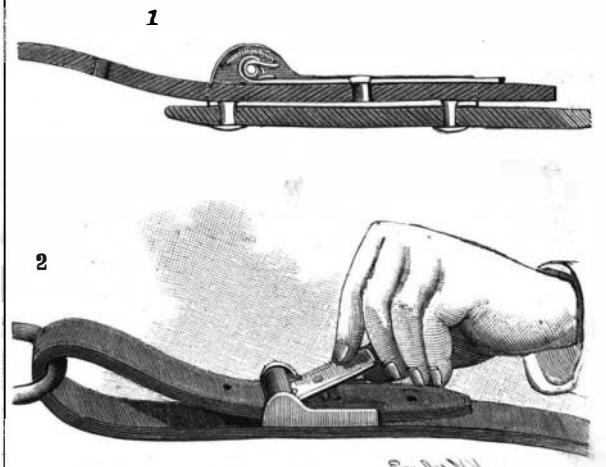

AYLSWORTH'S BUCKLE.

position. The shell forming a bearing for the axle journal is of the usual form, and in the bottom of the sponge-holding cavity below the journal is a shoe, readily inserted through the lid opening, the shoe having on its upper face ribs with serrated edges to sustain a mass of sponge at the front end of the journal. At the front top edges of the ribs is a vertical gate, held in side grooves of the box, to assist in keeping the sponge in place, and at the inner end of the box, in transverse slots, are pairs of sliding spring-pressed plates and gates preventing the escape of any lubricating material.

**AN INDEPENDENT LATHE CHUCK.**

The Westcott Chuck Co., of Oneida, N. Y., will not only have a large exhibit of its goods at the World's Fair, Chicago, but it is supplying, upon order from the

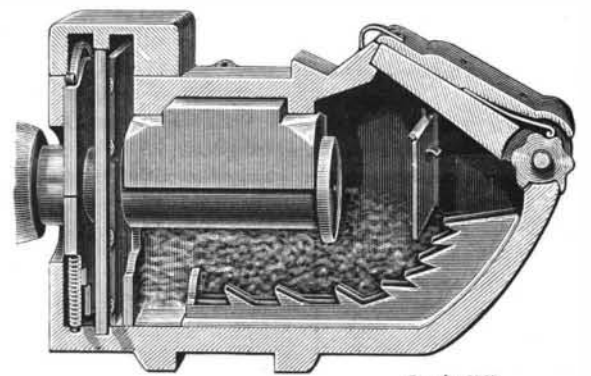

RADER & HUNTER'S CAR AXLE BOX.

Columbian Commission, the chucks that are to be used in a large model machine shop adjoining Machinery Hall. The accompanying illustration represents an entirely new independent lathe chuck, recently got out by the company, and for which a patent has been issued to Mr. James H. Westcott. It is very strong, because the end thrust and strain come on the chuck body at its strongest points. Each jack screw has a steel carrier threaded on one side and fastened by a set screw, half of the screw having a bearing on the carrier and the other half having a bearing in the body of the chuck. The thrust is thus distributed so as not to spring or break the chuck body, and the screw carriers are adjustable. The range of adjustment of the jaw carriers is also greatly augmented, as compared with other independent chucks, thus giving much greater



WESTCOTT'S "I X L" LATHE CHUCK.

capacity. In case of wear the carriers can be renewed at a small cost. All parts are interchangeable, and the jaws can be removed and the chuck body used as a face plate. The chuck is furnished with either two, three, or four jaws, or with special jaws.