

**A RAILWAY CAR FIRE EXTINGUISHING APPARATUS.**

The illustration represents an equipment for a railway car by means of which fires on the cars, bridges, or at stations or structures along the route may be extinguished. It forms the subject of a patent issued to Mr. William H. Beach, of Winona, Minn. A steam boiler is located in one corner of the car, and in connection with it is arranged a steam pump, the exhaust extending out through the roof, but being connected with the smoke stack of the boiler by a branch pipe. In a diagonally opposite corner of the car is a reservoir and heating drum, connected with the boiler by piping which extends around the car. Beneath the seats of the car, or in any other convenient position, are additional reservoirs, connected with the pipe extending around the car, the latter pipe being also connected with the suction chamber of the pump, while a pipe leads from its delivery chamber to a coupling nozzle. Coupling sections are also provided to effect a continuous circulation throughout the cars of a train equipped with this system. In addition to the coup-

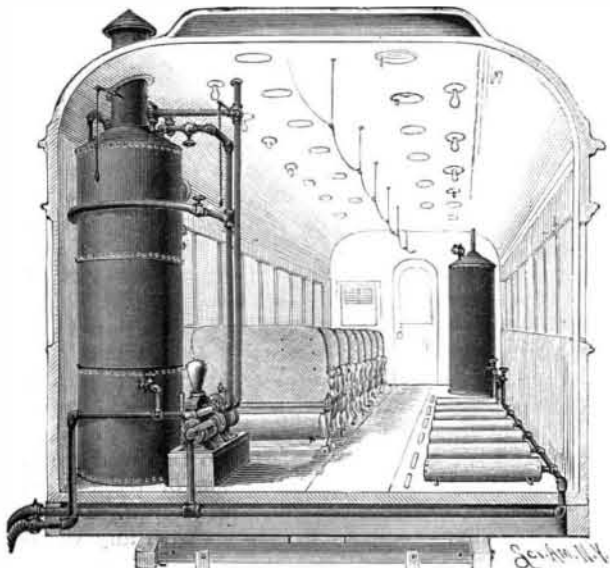

BEACH'S RAILWAY CAR FIRE EXTINGUISHER.

ling nozzle provided for connection with a delivery hose, the pump has a pipe or plug for establishing connection by means of a suction hose with the tank of the tender or any other convenient water supply, when a fire on a structure near the track is to be extinguished, such pipe being also utilized in filling the reservoir. The latter has a heating pipe arranged within it whereby the water may be heated by either the live or the exhaust steam, the necessary connections therefore being controlled by conveniently arranged valves, and when it is desired to pump water from the main reservoir along the auxiliary reservoirs may be cut off from connection therewith.

**AN IMPROVED AIR PUMP GOVERNOR.**

The illustration shows a sectional view and the application in position of an air pump governor adapted for use with air brakes, which is designed to be simple and durable in construction and effective and positive in operation. The steam inlet in the base of the governor casing is connected as usual with the boiler, while the steam outlet leads to the pump, as shown by the arrows. The inlet port is adapted to be closed by the reduced end of a hollow main valve in which is a coiled spring, which presses also against a plug screwing in one end of a cylinder above, of somewhat less diameter.

The upper end of the latter cylinder has a valve seat closed by an auxiliary valve on the reduced end of a stem sliding in a cylinder in the upper part of the casing, and of still smaller diameter. The first cylinder of reduced size is connected by a port with the steam inlet, and the smaller cylinder is connected by another port with the upper end of the cylinder in

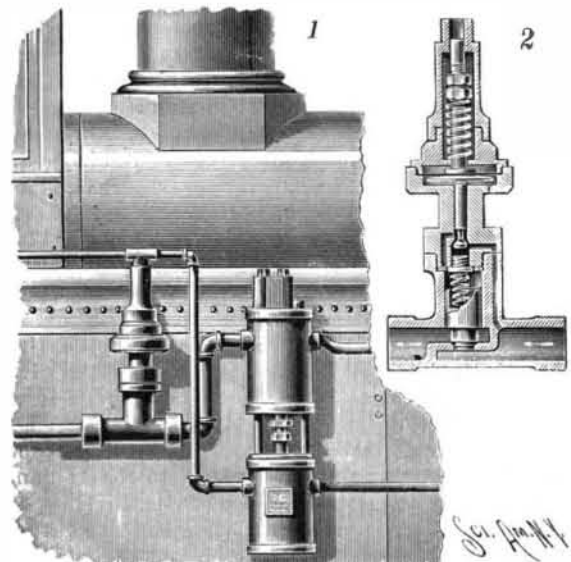

ORD'S AIR PUMP GOVERNOR.

which slides the main valve. The upper end of the valve stem of the auxiliary valve abuts against a disk held in an upper chamber, the disk being held on the lower end of a vertical stem, while on the top of the disk is arranged a diaphragm. The stem projects into an upper cap, an opening from which is connected with the air pipe of the air brake, the upper end of the stem being quite slack, so that air will pass down to press on the top side of the diaphragm. On the stem is a coiled spring, the tension of which is regulated by adjusting nuts, and the lower part of the chamber in which the diaphragm is located is connected by an opening with the outside, to serve as a drip for any water of condensation.

When the diaphragm is depressed by air pressure on its top side, the auxiliary valve is pushed off its seat so that live steam can enter and pass it, then passing into the upper end of the cylinder to press the main valve downward, the total pressure on the top of this valve being greater than that on the bottom, on account of the spring and the weight of the valve, so that the valve starts and moves downward as soon as the auxiliary valve is pushed off its seat. When the air pressure is reduced or taken off, the spring in the upper cap draws the stem and diaphragm upward, when the steam pressure on the reduced end of the main valve causes the latter to slide upward, and communication is established between the steam inlet and outlet.

This governor has no atmospheric exhaust; when the auxiliary valve is closed, the steam, which was holding the main valve on its seat, passes down the sides of the large cylinder into the pump, where it sustains warmth, and the remaining volume will be finally overcome by the pressure acting on the small end, which in opening applies pressure to the whole bottom side of the main valve before it has time to pass up to the top—hence the accelerated opening motion. But it will quickly settle to its working position by the steam in outlet equalizing upward into top end of cylinder, when it acts as an ordinary check valve, simply holding a slightly higher initial pressure on inlet side.

This pressure, if allowed to flow into the top end of the large cylinder by auxiliary valve opening, will cause the main valve to descend, thereby contracting the port opening, causing the pressure on outlet side to drop quickly, and as it is this outlet pressure which acts on part of the lower side of main valve, the downward motion of main valve will be accelerated till it reaches its seat, where the small end alone at the bottom is subjected to the same initial pressure as that which acts upon the whole top area. Hence the positive action.

For further information relative to this invention, address Mr. Craven R. Ord, No. 40 Law Street, West Toronto, Ontario, Canada.

**A COMPACT AND POWERFUL FLOORING CLAMP.**

The illustration represents a strong and readily operated device to facilitate the laying of floor boards, whether they are straight or warped on their edges. It has been patented by Mr. James H. Giesey, of No. 2235 Chapline Street, Wheeling, West Va. Fig. 1 is a side view of the device secured to a joist in operative position, Fig. 2 being a top plan view in section. The clamp is designed to be self-locking to the joist it is mounted on, the act of pushing the presser bar against the floor board tightening the grip of the device on its support, while its withdrawal releases the clamp. The clamping sections are pivoted in ears of a base plate, limbs of these sections extending below the pivotal points and having adjustable set bolts near their free ends, the inner ends of these bolts being pointed to afford secure engagement with the beam. Above the pivotal points the clamping sections have each an integral arch, and the rear portions of their limbs are curved outwardly and upwardly in opposite directions on each side, producing cam curves on the arch portions, the curved top surfaces of both arches being serrated to produce ratchet teeth. At the center of the base plate is pivoted an operating lever having a sliding locking dog loosely held on the lever to reciprocate vertically a limited distance. The usual tripping handle is jointed to the operating lever, and connected by a link bar to the dog. The presser bar, pivoted upon the operating lever, has a forked front end, each limb of which is bent upward at the edges so that the faces of the limbs will fit squarely over the tongue of a floor board. When this clamp has been made to straddle a joist, and the pointed bolts have been properly adjusted, the pushing forward of the operating lever brings these bolts into engagement with the joist and at the same time moves the presser bar against the floor boards, the locking dog holding the lever at any point of rocking adjustment.

THE surveyors' instruments, drawing appliances, and similar articles manufactured and imported by the Keuffel & Esser Company, of New York City, embrace such a wide variety of goods as to require a catalogue of nearly three hundred pages for their enumeration, with but the briefest description. The firm has been long established, has well earned a high reputation, and conducts a very extensive business.

**A PEN HOLDER TO FACILITATE MAKING WAVED LINES.**

A pen holder with which waved or irregular lines may be made with facility is shown in the accompany-

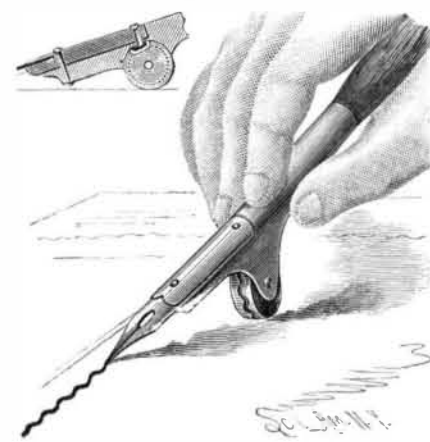

RICHARDSON'S PEN HOLDER.

ing illustration, and has been patented by Mr. George H. Richardson, of Old Town, Me. This pen holder is made in two parts, the front portion, carrying the pen, being pivoted near its forward end to the forward part of the main portion. The latter carries a wheel or roller which rests on the paper as the instrument is moved along, and on the periphery of this wheel is a zizzag groove corresponding to the waved line or lines it is desired to produce on the paper. A stud or pin at the rear end of the pen-carrying portion of the holder, as shown in the sectional view, engages this groove, and causes the pen to vibrate as the wheel revolves. The device is designed to be especially useful to draughtsmen and others in making fancy borders, as well as

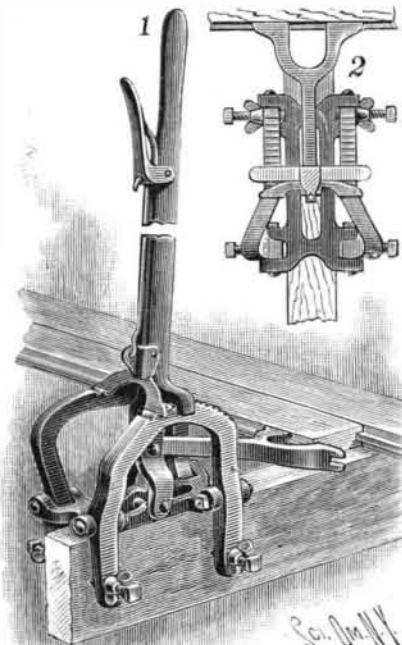

GIESEY'S FLOORING CLAMP.

in ruling checks, drafts and other papers in business offices.

**A SIMPLE AND RELIABLE TRAP.**

The accompanying illustration represents a trap, patented by Mr. Walter Pead, of Durban, Natal, South Africa, adapted to catch animals alive, and which may be made strong enough to capture wild animals of various kinds. One end and a portion of the top of the box is closed with wire rods, admitting light, so that the bait can be readily seen, and at the opposite end of the box are grooves for the reception of a sliding gate, of metal, and of sufficient weight to assure its quick descent when released. The bait hook is pivotally suspended on a transverse wire rod, and an

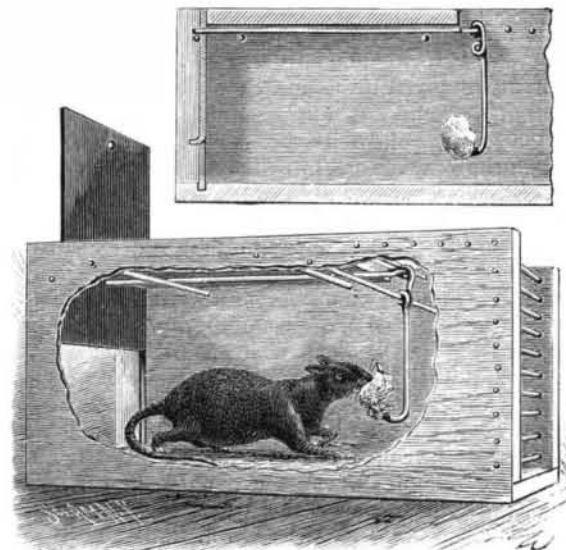

PEAD'S ANIMAL TRAP.