

AN IMPROVED NUT LOCK.

The device herewith illustrated, which has been patented by Mr. James M. Teifer, Minerva, Ohio, is designed to hold one or a series of nuts in place, and is adapted for use on all kinds of machinery, as well as

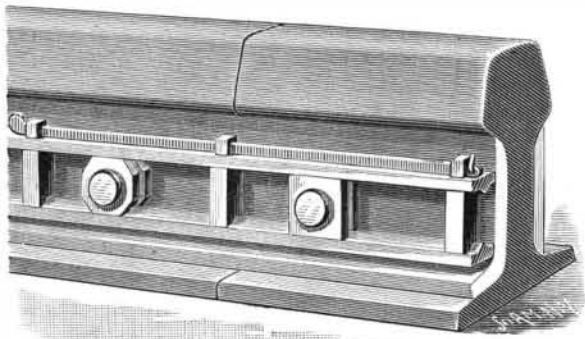

TELFER'S NUT LOCK.

for railway rail joints. Integral with a base bar on the upper surface of which is a longitudinal ridge are posts, each having on its upper end a slightly reduced eye, over which is passed a top bar resting on the top of the posts. Through the several eyes of the posts on the top of the top bar is passed a key having a head on one end, and provided at its other end with a ring, cross pin, or other device, to hold the key in place. On the under side of the top bar is a longitudinal ridge, and the ridges of the top bar and base are adapted to engage correspondingly shaped grooves on the sides of the nuts to be locked, the latter being first turned so that their bottom and top sides will be in line with one another. In the application of the device to the nut of a single bolt, a dummy bolt and nut may be employed.

BOOMER & BOSCHERT'S PRESSES.

The illustration represents a simple and compact yet extremely powerful hydraulic press, suitable for baling cloths, finishing ginghams, note and letter papers, and other uses. It is one of many kinds of presses made by the Boomer & Boschert Press Company, of Syracuse, N. Y., a firm which makes a wide variety of presses, both hand and power, for almost every use, including presses for wine and cider, lard, tallow and oil, vulcanized rubber and leather belting, etc. The knuckle joint press made by this firm has been in use over twenty years, and has attained a popularity that is unsurpassed, while their power screw press, more recently introduced, is almost as widely known. In their hydraulic presses they use a large sized ram in proportion to the amount of power to be obtained, and hence employ a much lower water pressure than usual, with a corresponding freedom from leakage and loss of time in stopping for repairs. They make hydraulic presses with from one to eight or more rams, according to the uses to which the presses are to be put. These

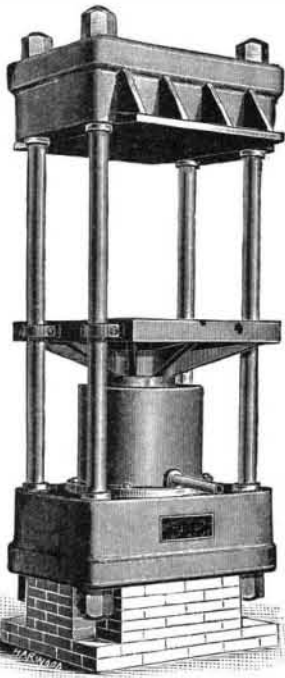

A COMPACT HYDRAULIC PRESS.

presses are manufactured under about forty patents owned or controlled by the firm, and covering nearly every detail of construction. Special tools have also been designed to insure uniformity of product.

AN AUTOMATIC ELECTRICAL DAMPER REGULATOR.

The illustration represents an apparatus, patented by Mr. John M. Snyder, of Hollidaysburg, Pa., for controlling dampers which regulate the draught of furnaces, the picture showing the application of the improvement for operating the check damper in the smoke pipe and regulating the air draught at the base of the furnace. On one end of a shaft journaled in a suitable frame is a ratchet wheel, and a scape wheel with two teeth, carrying a spring-pressed pawl to engage the ratchet wheel. On one end of the drum is wound a cord supporting a weight at its outer end, while on the other end of the drum a cord is wound in the opposite direction supporting at its free end a smaller weight, the unwinding of one cord winding the other cord. An electro-magnet is attached to the frame, and on a projecting arm is pivoted an armature-carrying lever, the lower end of which is adapted to engage the teeth of the scape wheel. A stop prevents the lever from touching the scape wheel itself, while a spiral spring holds it normally in position to engage one of the two teeth of the wheel. To one end of the shaft is attached a slotted crank, carrying an adjustable pin, a cord from which is extended to connect with the pipe damper and also with the draught opening of the furnace, both of which are operated simultaneously. Where the temperature is to be automatically regulated a thermostat is used, the compound bar of which extends between two electric contact screws, and upon the end of the shaft opposite that carrying the slotted crank is a grooved disk, two contact springs attached to the frame extending into the groove of the disk. On the disk, at a point ninety degrees from one of the teeth of the scape wheel, is a pin, and the contact springs are each connected with a different contact screw of the thermostat. One pole of the battery is connected with the fixed end of the thermostatic bar and the other pole with one terminal of the electro-magnet, the remaining terminal of the latter having a flexible connection with the pin in the grooved disk. When the thermostatic bar is expanded by heat to make contact with one of the contact screws, the circuit through the battery is closed upon the electro-magnet, thus operating the armature-carrying lever, so that the heavier weight revolves the drum, carrying around the scape wheel and crank, and operating the cord connected with the dampers, to close one and open the other. While this half revolution of the drum shaft is taking place, the circuit is broken between the contact spring and the pin in the disk, and the armature is released, so that the lever engages the next tooth of the scape wheel. A reduction of the temperature makes the circuit through another contact screw of the thermostat and the other contact spring extending into the grooved disk, when the armature lever is again drawn forward, allowing the other tooth on the scape wheel to pass, and the half revolution thus made again operates the dampers.

A HOT WATER VENTILATING HEATER.

The heater shown in the accompanying illustration is arranged to operate as a warm air furnace, supplying properly heated and moistened air to registers in the principal lower apartments of a house, as well as affording a continuous circulation of water for heating by direct hot water radiation in all the rooms. This combination insures a circulation of fresh warm air throughout a building, and, when proper air exits are provided, is designed to afford a perfect system of ventilation, by which the atmospheric condition of a house will be much superior to that of a building heated only by direct radiation.

The hot water chambers, C, C, are flat and round, made of heavy cast iron, and connected together by upright connections, D, D, screwed into shoulders on the chambers with lock nuts, over asbestos and lead-filled cup joints. These chambers are suspended inside the combustion chamber in such manner as not to impair the draught, while they are designed to sufficiently retard the exit of the products of combustion to extract practically all the heat therefrom. Each alternate section extends from side to side of the combustion chamber, and the products of combustion are forced to traverse over the entire top and bottom surface of each section until they pass into the exit flue, A.

The return pipe of the circulatory system enters the lower chamber on any side of the heater which may be most convenient, when the water circulation is necessarily positive and continuous, the water circulating upward as indicated by the arrows, through every portion of the interior of each chamber, before reaching the distributing feed pipe, and passing as many times over the fire as there are sections used. The warm air supply is produced by taking the air from the outside through the cold air duct, Y, at the bottom, whence it passes upward around the furnace, in-

side its double outer casing, to the distributing warm air pipes at the top, whence it passes, as shown by the arrows, to the registers in the principal apartments nearest to the heater.

This heater has the advantage of a thoroughly test-

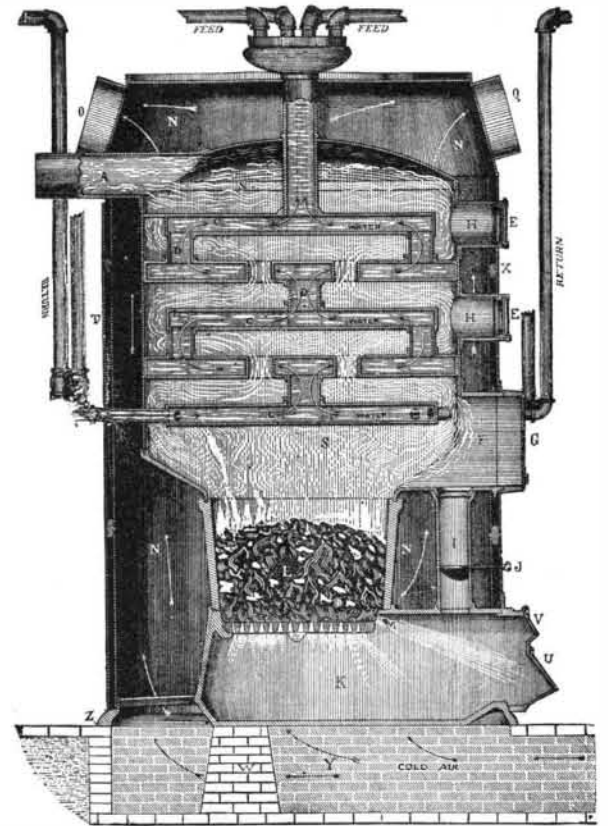

THE PEASE HOT WATER VENTILATING HEATER.

ed construction, being in its main elements of the same make as a heater manufactured by the same firm which has been in successful use for many years past, but which is here adapted to the combination system of direct and indirect heating.

It is manufactured by the J. F. Pease Furnace Company, of Syracuse, N. Y., who will, on application, furnish descriptive pamphlets and prices to all interested.

AN ADJUSTABLE STUFFING BOX.

The construction shown in the illustration, styled by the inventor the engineer's stuffing box, is designed to reduce to a minimum the labor and attendance ordinarily required to insure perfect and constant lubrication, while decreasing or removing the liability to hot piston rods, etc. The central part of the stuffing box has conical cavities in its opposite ends, beyond which cavities extend cylindrical collars fitting glands having cavities on their inner faces, thus forming two inner spaces, one for fibrous and the other for metallic packing. The glands are convex on their outer side and fitted to concave plates, the outer faces of the glands and both faces of the concave plates having annular grooves for water or steam packing. This stuffing box is intended to be loosely inserted in the ordinary box, and held in place by an outer plate joined thereto by threaded studs, a spring being interposed between the nut on the end of each stud and the plate. This construction is designed to allow

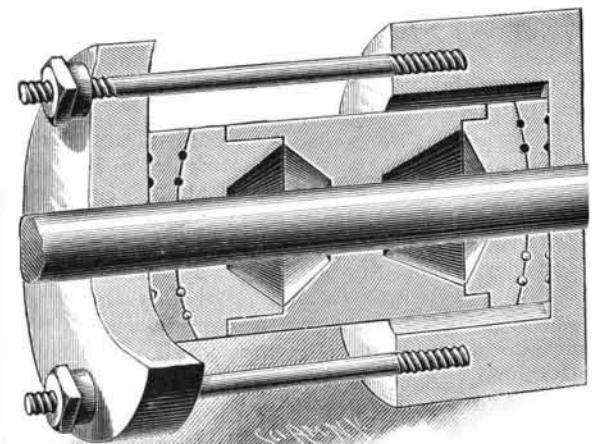

HITCHCOCK'S ADJUSTABLE STUFFING BOX.

for a slight lateral movement and still maintain a tight joint. Further particulars touching the invention may be obtained of the patentee, Mr. George H. Hitchcock, No. 101 Fairchild Street, Danville, Ill.

RENEW PROMPTLY.—We would call attention to the fact that the term of subscription of a large number of our readers expires with the next number of the SCIENTIFIC AMERICAN and SUPPLEMENT, and we wish to urge prompt renewals. This greatly facilitates the making up of our lists for the coming year and will secure the reception of the papers without interruption by the subscriber.

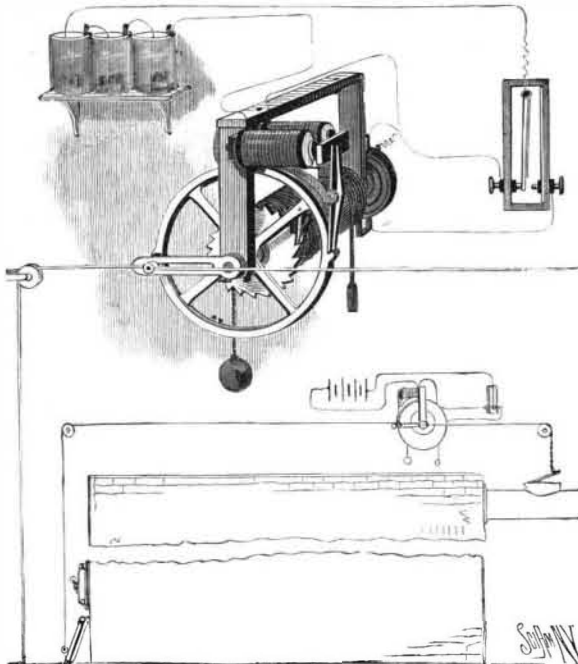

SNYDER'S ELECTRICAL DAMPER REGULATOR.