

EXPERIMENTS IN MAGNETISM.

BY GEO. H. HOFFMANN.

Nature furnishes permanent magnets "ready made," the lodestone being an example of such a magnet. She is able to induce magnetism in magnetic bodies, the



Fig. 1.—MAGNETISM BY INDUCTION FROM THE EARTH.

earth itself being the great magnet by which the induction effects are secured. It is to the directive force of this great magnet that the compass owes its value.

The magnetism of the lodestone is due, doubtless, to a long exposure to the inductive influence of the earth's magnetism. Any body of magnetic material becomes temporarily magnetized to some extent when placed in the magnetic meridian parallel with the dipping needle, and if it be a body like soft iron, without coercive

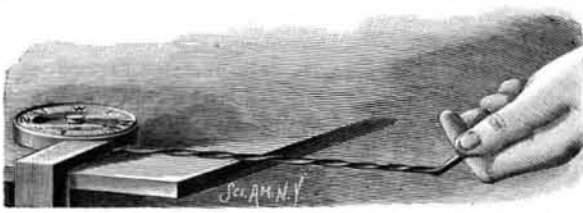

Fig. 2.—DEVELOPMENT OF MAGNETISM BY TORSION.

force, it loses its magnetism when arranged at right angles to this position in the same plane. This may be readily demonstrated by placing a rod of well annealed wrought iron in the magnetic in an inclined position, as indicated in dotted lines in Fig. 1, with its upper end in close proximity to the end of a compass needle. The needle will be instantly deflected, showing that the rod has become magnetic. When turned in the plane of the magnetic meridian to a position at right angles to its former position, it will lose its

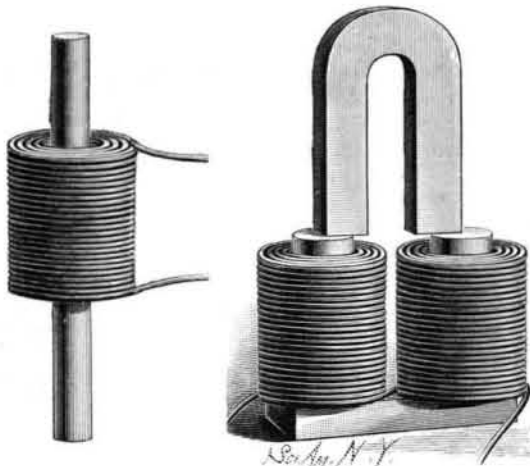

Fig. 3.—MAGNETIZATION OF BARS.

Fig. 4.—MAGNETIZATION OF U-SHAPED BARS.

magnetism and will therefore be no longer able to repel the needle. By placing a bar of hardened steel in the magnetic meridian and striking it several blows on the end with a hammer, it becomes permanently magnetic, not strongly, but sufficiently to exhibit polarity when presented to a magnetic needle.

By twisting a rod of soft iron having one of its ends in proximity to a magnetic needle, it is shown by the deflection of the needle that magnetism is developed by torsion. By this and similar experiments it may

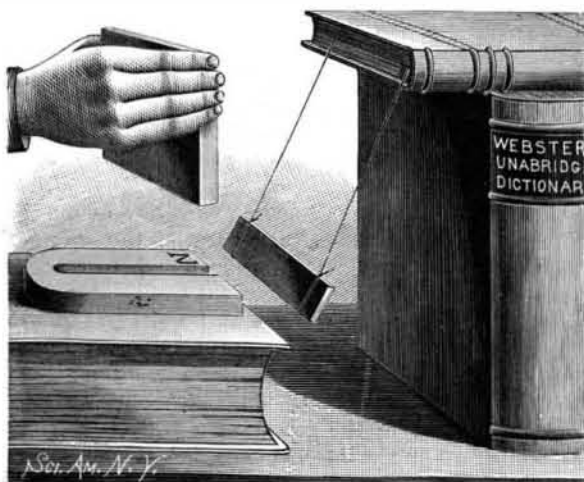

Fig. 5.—MOTION PRODUCED BY A PERMANENT MAGNET.

be shown that stress and compression favor magnetization.

Artificial magnets are produced by the contact of hardened steel with magnets or by means of the voltaic current. The latter is the more effective method, provided a strong current and a suitable helix or electro-magnet is available. For the magnetization of bars of steel a helix like that shown in Fig. 2 is needed. Its size and the amount of current required will, of course, depend upon the size of the bar to be magnetized. For all bars up to 3/8 inch diameter, a helix 5/8 inch in internal diameter, 2 inches external diameter, and 2 1/2 inches long, made of No. 16 magnet wire, is sufficient. A current from five or six cells plunging bichromate battery is required, or in lieu thereof, a similar current from a dynamo.

The bar to be magnetized is hardened at the ends and placed in the helix, the current is then applied, and the helix is moved from the center of the bar to one end, then to the opposite end and back to the center, when the current is discontinued, and the bar is removed. If several bars are to be magnetized, they may be placed end to end, and passed through the coil in succession. The magnetization of U-shaped bars may be accomplished by means of an electro-magnet formed of two coils above described and a suitable soft iron core. The U-shaped bar is placed on the poles of the electro-magnet as shown, when the current is sent through the coils for a short turn and then interrupted. Another method, which is perhaps more effectual, consists in drawing the U-shaped bar several times across the poles of the electro-magnet.

In the search for perpetual motion, vain efforts have been made to discover a substance which could be interposed between the magnet and its armature, and removed without the expenditure of power, and which would intercept the lines of force, so as to allow the armature to be alternately drawn forward and released, but no such substance has ever been discovered. The lines of force may be intercepted by a plate of soft iron placed between the magnet and its armature, but it requires more power to introduce the plate into the magnetic field, and withdraw it therefrom, than can be recovered from the armature. Fig. 5 illustrates an experiment showing how motion may be produced by the force of a permanent magnet. An armature is suspended by threads in the field of a permanent magnet. The magnet attracts the armature, slightly deflecting its suspension from a true vertical line. The introduction of a soft iron plate between the magnet and its armature intercepts the lines of force, thus releasing the armature, when it swings back under the influence of gravitation. If at this instant the iron plate is withdrawn, the magnet again acts upon the armature, drawing it forward. Another introduction of the iron plate into the field again releases the armature, when it swings back, this time a little farther than before. By moving the iron plate in this manner synchronously with the oscillations of the armature, the armature may be made to swing through a large arc.

A Rival to Western Union.

The South Atlantic Telegraph Company, of Baltimore, Md., has been incorporated with a capital stock of \$50,000. It is said that the new company is to form a link in the Mackay-Bennett and Postal Telegraph Cable Company system, and is for the purpose of purchasing and owning the lines of that system in Maryland, which are now only leased. The scheme embraces an amalgamation with the Southern Telegraph Company, of Virginia; the Southern Telegraph Company, of North Carolina; and the Southern Atlantic Telegraph Company, whereby lines of wire may be secured extending to New Orleans and covering the entire South and Southwest. This entire system is to be controlled by the Mackay-Bennett management.

IMPROVED STRUCTURE FOR USE AS A SILO.

The construction herewith illustrated is designed to be erected on the surface of the ground for use as a silo. It has been patented by Mr. James E. Rankin, of Elk Rapids, Mich. The preferred size is about sixteen feet square by sixteen feet high, the structure consisting of horizontally arranged and spaced rectangular frames, with vertical linings secured to their inner faces, and a diagonally arranged sheathing attached to the outer face. The inventor styles this structure a straw stack silo, as it may be built with only the inside lining, by using the refuse straw therewith, although a waterproof material may be secured to the diagonal sheathing, with clapboarding outside thereof. The rectangular frames are preferably about nineteen inches apart, sixteen inches wide, and one inch thick, affording large air space between the outer and inner walls, Fig. 2 showing the relative position of the frames and Fig. 3 the manner in which they are joined at the corners by means of an angle bar having its extremities bent in opposite directions to embrace the edges of the approaching sides. There is a door with a three-foot square opening in the center of one side, such door being adapted to be closely sealed, while the roof is supported some three feet above the walls of the structure by means of posts bolted to the frame.

AN IMPROVED WIRE STRETCHER.

A device of simple construction, which may be readily attached to a post and engaged with fence wires it is desired to tighten, the device being one which may be applied with equal convenience to either side of the post, is illustrated herewith and has been patented by Mr. George R. Hughes, of Savoy, Texas. It is of metal, with the exception of an attachable wooden handle, and the body of the device is essentially T-shaped, the members constituting the head being slightly inclined and provided with teeth on their inner face. Fig. 1 is a view of the device in which the dotted lines indicate the relative position of the stretching lever to the other parts after it has been thrown forward to stretch the wire and draw it against the post. On the other end of the main member is a

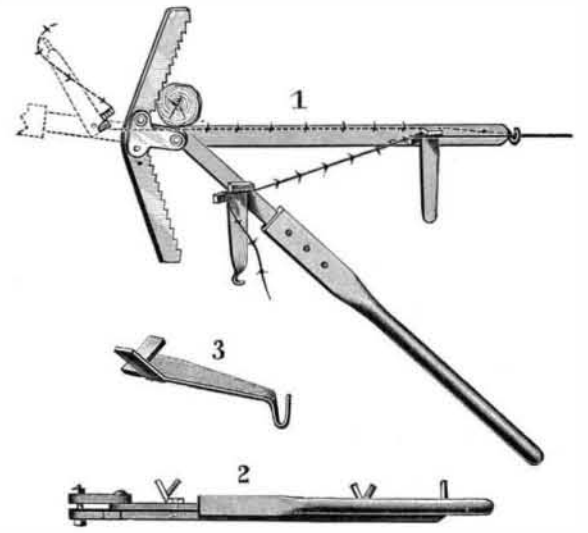

HUGHES' WIRE STRETCHER.

hook or eye through which the wire is first passed, and near it is pivoted a lever with jaws, similar to those shown in Fig. 3, the space between the jaws being just sufficient to receive the wire. Near the head is pivoted a plate with enlarged oval end having apertures in each extremity, adapted to receive a bolt or screw for pivoting the plate to one of the arms of the head, according to the side of the post it is desired to operate upon. The same plate is also pivotally connected to the lever to which the handle is attached, there being also pivoted to this lever a clamping lever having a hook, as shown in Fig. 3. The wire having been passed through the eye and the first clamping lever, the latter is carried around in parallel position to the left, and the jaws of the next clamping lever are engaged with the wire, which is drawn taut, after which the handle lever is carried to the left to the position shown in dotted lines. Great tension is thus obtained, while the wire is firmly held against the post, in position for tacking or making fast in the usual way.

Dangers of Petroleum.

It is remarked by Colonel Majendie that the risk from fire and explosion is not limited to cases in which whole or considerable cargoes of petroleum spirit are shipped. A few barrels, or even one, may suffice. One gallon of petroleum spirit, it has been shown, is enough to render 16,000 gallons of air inflammable, representing a space exceeding 2,000 cubic feet. The penetrating nature of the vapor increases the risk—a fact which has been proved by direct experiment, as well as indicated by actual misfortune. This quality, combined with the high specific gravity and flame-carrying power of the vapor when combined with air, renders its presence highly dangerous, even when the quantity may be small.

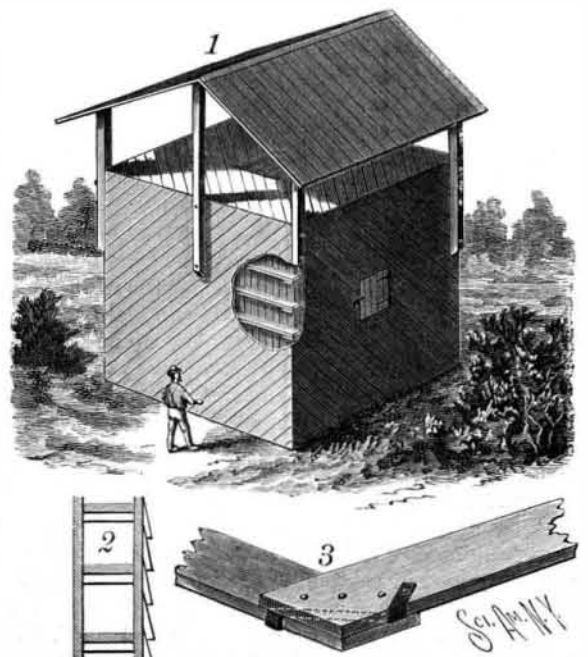

RANKIN'S STRUCTURE FOR USE AS A SILO.