

IMPROVED DEVICE FOR DETACHING ANIMALS.

A device by means of which animals may be simultaneously released from their fastenings in stalls in the event of fire, or as may be otherwise desired, without the necessity of the operator entering the several stalls,

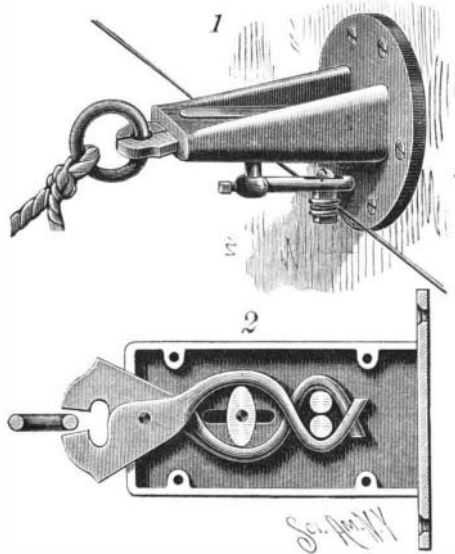

KUBATZ'S DEVICE FOR DETACHING ANIMALS.

or even the building, is illustrated herewith, and has been patented by Mr. Ignatz J. Kubatz, of No. 164 East Ninety-seventh Street, New York City. The body of the device consists of a casing, permanently attached by means of a flange to the front of the stall or any suitable support within or adjacent thereto, as shown in Fig. 1. In the top and bottom plates of the casing are longitudinal recesses covered by a cap plate, the cap plate of the lower section sliding longitudinally. A pintle is passed up through an aperture in the sliding plate, and between the top and bottom plates an elliptical cam is rigidly fastened to the pintle, a lever being secured to the lower end of the pintle. Gripping fingers are pivoted near the outer end of the casing by a pin adapted to travel in the slots in the casing, and two stops are arranged side by side near the rear end of the casing, the gripping fingers being so bent upon

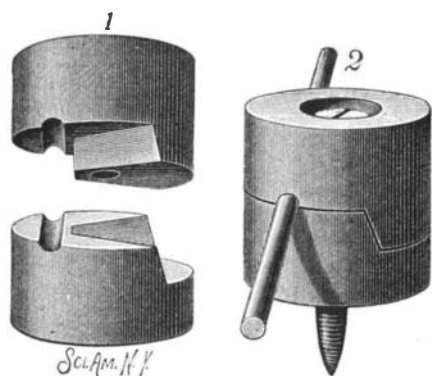

BROWN'S INSULATOR.

themselves as to form a central circular section surrounding the cam, as shown in Fig. 2, the forward ends of the fingers being hook-shaped, and the fingers being so pivoted that they are free to move one upon the other to close or open the hook section. When the device has been fixed in the several stalls, a rope, chain, or wire is attached to the several levers operating the pintles to which the elliptical cams are secured, such rope or chain leading to any desired point inside or outside of the barn. The normal position of the lever is parallel with the casing, and the cam is then in position to allow the outer ends of the fingers to be closed to retain the ring of a hitching rope. By pulling the rope, the levers are brought to a right angle to the axis of the casing, and the cam transversely thereto, which forces apart the gripping fingers, dropping the ring therefrom. To attach the animals again, the ring is inserted between the fingers and the lever swung back to its normal position, the striking of the lever upon the

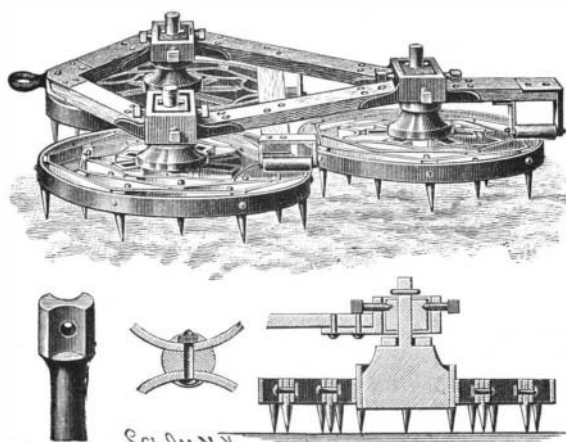

BROWN'S ROTARY HARROW.

flange causing the cam-carrying pintle to travel forward in the casing and close the hooked ends of the gripping fingers upon the ring.

IMPROVED HOOD FOR STOVES OR RANGES.

The illustration herewith represents a device for conveying the steam, smoke, and disagreeable odors arising from a stove or range in cooking or washing to the chimney, thus preventing their spread through the house. It has been patented by Mr. Hermann Neef, of Jefferson City, Mo. A cone-shaped hood is employed large enough to cover a portion of the top plate of the stove, this hood being detachably connected with a telescopic pipe section by means of a bayonet joint. The outer lower edges of the hood have grooves, in each of which is held a removable wing, which may be turned back upon the hood when not in use, and which project downward and outward from the hood when in use, forming an enlargement of the hood, so that nearly the whole top of the stove may be covered thereby. The hood may, if desired, be furnished with wire gauze ventilators, and a damper is provided to cut off the connection between the telescopic pipe sections and the main stove pipe when the fire is being kindled. The hood is counterbalanced and held in any desired position of adjustment by a weight and a wire rope passing over pulleys and down through the pipe sections, the extremity being attached to the inner surface of the lower pipe section, while the pulleys may be attached to the ceiling of the apartment.

being mounted to tilt within a box forming part of the main frame. Just above the rear of each of the wheels there is mounted an anti-friction wheel or roll, each roll being firmly supported by the main frame, by which the gudgeons are relieved of undue

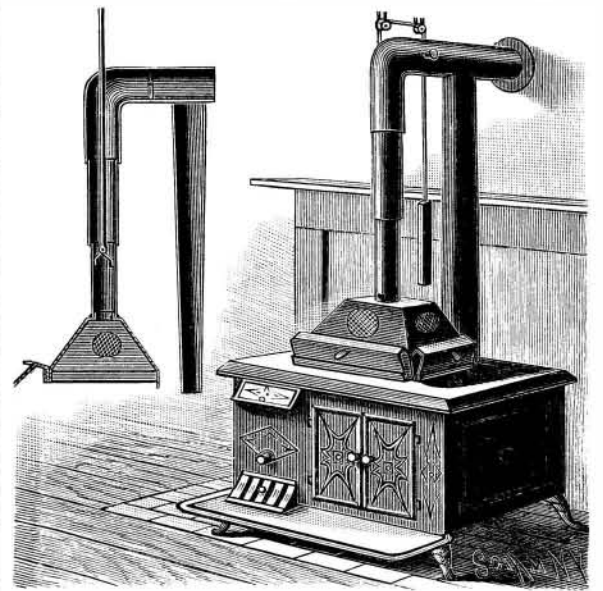

NEEF'S STOVE HOOD.

AN INSULATOR FOR ELECTRICAL CONDUCTORS.

An improved insulator for receiving electrical conductors and holding them firmly, without the necessity of using binding wires or of twisting them together, is illustrated herewith, and has been patented by Mr. Warren C. Brown, of Tarrytown, N. Y. The insulator consists of two halves, which together form a cylinder with a transverse aperture for receiving the wire, and an axial countersunk hole for receiving the screw supporting the insulator. The halves each have a semi-circular groove, which, when the two grooves are clamped together, forms the transverse aperture for the wire.

A NOVEL NUT LOCK.

The nut lock is one of the inventions which depends for its commercial value quite as much upon the facility with which it can be manufactured as upon the simplicity of its application and its effectiveness in service. Any device costing much more than a common bolt and nut, together with an ordinary set nut, is likely to fail of general adoption.

The nut lock invented by Thomas W. Patten, of 517 West Baltimore Street, Baltimore, Md., and which is shown in the annexed engraving, has the important qualification of low cost, as well as the advantage of being as readily applied as an ordinary nut and washer. It has also the further advantage of being perfectly secure, while having the same external appearance as an ordinary nut and washer.

The washer, which is placed under the nut as usual, is provided with an eccentric boss which is bored to fit the bolt loosely, and is furnished on its inner periphery with transverse teeth or notches extending from the thinnest to the thickest part of the boss. The nut is provided with an eccentric recess for receiving the eccentric boss of the washer, and the outer circumference of the recess is provided with transverse serrations for engaging the boss.

When the nut is turned upon the bolt, the friction of the washer upon its bearing causes the washer to remain stationary, while the further turning of the nut clamps the washer to its seat, and by engagement with the eccentric boss moves the washer edgewise, so as to bring its teeth into engagement with the threads of the bolt and cause them to cut into the threads transversely, thereby giving the washer a firm hold on the bolt. The teeth of the nut by engagement with the boss of the washer prevent any back motion of the nut.

AN IMPROVED ROTARY HARROW.

The accompanying illustration represents a self-cleaning harrow, each section of which revolves upon its own axis to clean itself of rubbish as it moves along, while each set of harrow teeth is free to conform to any irregularity there may be in the ground. This invention has been patented by Mr. Asa C. Brown, of Eugene City, Oregon. The harrow teeth are supported by truss wheels, bolts passing through apertures in the head of the teeth, as indicated in two of the small figures, and the construction admitting of the employment of several sets of teeth in each wheel. A central sectional view of one of these truss wheels, in connection with a portion of the harrow frame, is shown in the illustration, each wheel being mounted to turn freely on a gudgeon held within a block, and this block

strain. With such a harrow each wheel is free to revolve independently of the other wheels, and each wheel is free to tilt so that the harrow teeth will conform to any irregularities in the ground at right angles to the line of draught. A small pair of wheels with seat for a driver may be attached if desired.

AN IMPROVED PLANT NEST.

The illustration herewith represents a simply made nest for facilitating the handling of large numbers of plants, taking the place of earthen pots, giving each one separate soil and drainage, and facilitating transplanting without disturbing the soil and roots. It has been patented by Mr. Louis Vaughan, of Blair, Neb. These nests may be made by boring nearly through a

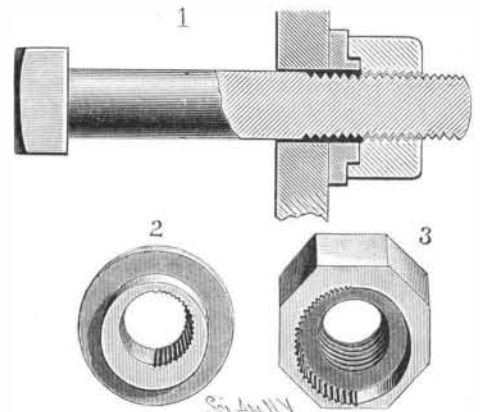

PATTEN'S NOVEL NUT LOCK.

plank to form cavities large enough for the pots or cells, leaving enough wood to form bottoms, in which small perforations are made for drainage. Sections are then made by slitting the plank perpendicularly through each row of cells, chamfers being cut from the top down, on the line of each slit, to a rectangular groove running across the ends of the nest or plank. Semicircular grooves are also made across the bottom of the plank near each end, each of these grooves, with the one running across each end, receiving a piece of sheet metal to form a guide and foot, through which a piece of spring wire is passed lengthwise, the ends thereof being curved to form clamps holding the sections together. The elasticity of these spring clamps permits the sections to swell and shrink without injury to the nests, and the bend or foot of the sheet metal piece holds up the sections from the table or shelf on which they may stand, to allow for free drainage and circulation of air.

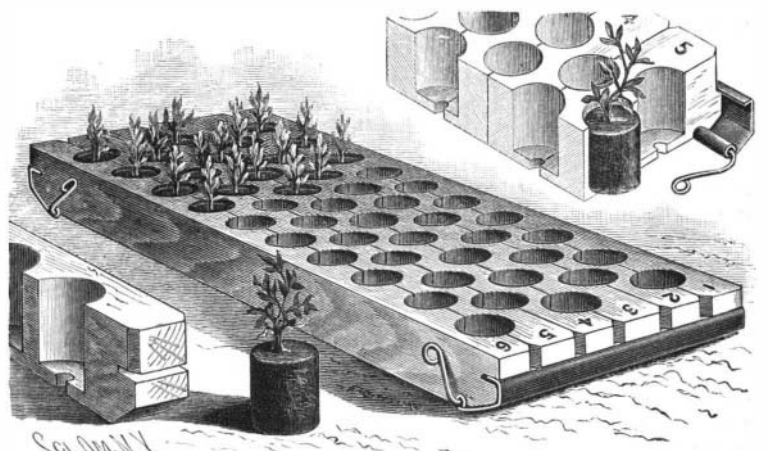

VAUGHAN'S PLANT PROPAGATING NEST.