

FERDINAND DE LESSEPS.

Vicomte Ferdinand de Lesseps, now in his eighty-third year, is the very personification of energy and perseverance, and will figure in history as one of the world's boldest engineers. When, in 1831, he was sent as consul-general to Alexandria, he found the idea of a canal across the Isthmus of Suez a fertile topic of discussion, and, becoming deeply interested in the subject, he proposed to Mehemet Said, with whom he was on intimate terms, a plan for executing the project; but it was not till 1854 that his enterprise received the official sanction of that potentate. The opposition that he received from England, the obstacles placed in his way by the Sultan and the Porte, and the success that finally crowned all his efforts, when the Empress Eugenie opened the canal in November, 1869, are well known matters of history. Having accomplished this great work, M. De Lesseps determined to retire for a time on his well earned laurels, and a few days after the inauguration of the Suez Canal he married a young Creole lady, Mlle. Helene Autard de Bragard, by whom he has had nine children.

Honors now began to fall thick and fast upon him. He received the grand cross of the Legion of Honor from Napoleon III., who had always befriended him. England now tried to make amends by according him an enthusiastic welcome on his visit in 1870, when he received the grand commandership of the Star of India and the freedom of the City of London. In 1878, the long discussed question of the Panama Canal came to the front, the committee of investigation handed over its concession to M. De Lesseps, the International Scientific Congress proclaimed that the project could and ought to be carried out, and, in December, M. De Lesseps and his wife and children (the latter then three in number) started for the isthmus to inspect the route for himself. He returned, after some months' absence, thoroughly impressed with the practicability of the scheme. At first, it was found difficult to procure funds, and the scheme was abandoned for a time; but, finally, a company was formed, and the French engineers left Paris on the 3d of January, 1881, to proceed to the work, which was begun February 24 of the same year.

The enterprise has since been carried on under many vicissitudes, due to the geology of the country and lack of funds. The latest project is to abandon the dead canal for a time and to construct a temporary lock canal.

M De Lesseps has been twice married. Our engrav-

ing shows the old hero and his young wife and their children. For the engraving we are indebted to the *Illustrated London News*.

A REGULATOR FOR STEAM RADIATORS.

An improved device for controlling and regulating the heat given off by a steam radiator is illustrated

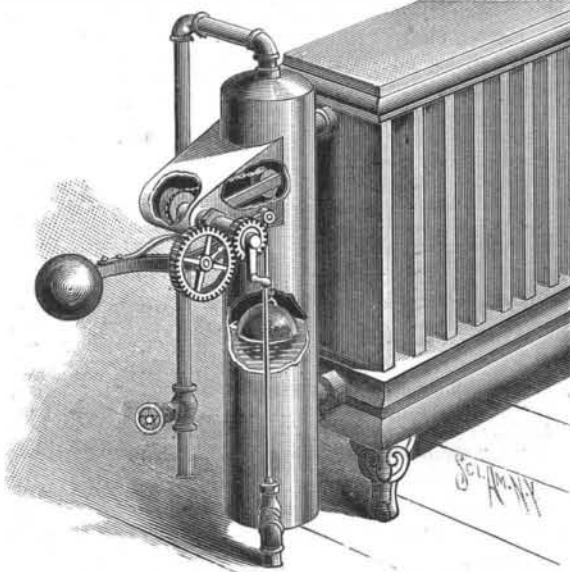

BRITTS' RADIATOR REGULATOR.

herewith, and has been patented by Mr. Peter W. Britts, of Gunnison, Col. The radiator is connected at its top and bottom with the upper and lower ends of a tank placed near, thus establishing a steam and water connection whereby the water level is kept the same in both, the tank being connected at the top with the steam supply pipe, and having at the bottom a water outlet pipe in which is a gate valve. The valve rod in the outlet pipe is pivotally connected with a weighted lever fastened on a sleeve turning in bearings on a hollow branch arm extending from one side of the upper end of the tank, a shaft passing through the sleeve carrying on its outer end a pinion meshing into a gear wheel turning on a stud secured on the weighted lever. A spring pawl on the lever arm engages the teeth of the gear wheel, to prevent a return movement of the pinion and its shaft, and the latter has on its outer end a crank arm, while on its inner end, inside

of the branch from the tank, is a drum on which winds one end of a chain or rope passing over a pulley held on the free end of an arm secured to the sleeve. This arm, the sleeve, and the weighted lever thus form one piece, so that when the arm swings downward the weighted lever swings upward, and *vice versa*. The pulley projects into the tank, and the rope or chain passing over it carries at its lower end a weighted float, which rises and falls with the water level in the tank and in the radiator. The float can be raised or lowered and adjusted at any desired height by means of the crank arm and pawl, a pointer on the gear wheel indicating the height of the float in the tank. The weight of the suspended float holds the weighted lever arm normally in position, so that the valve in the outlet pipe remains closed, as the water of condensation accumulates in the radiator and the tank, until the water raises the float, when the weighted lever arm swings downward, and the rod pivotally connected therewith opens the valve in the outlet pipe. The float moves downward with the falling water, and again exerts its pressure to close the valve when sufficient water has escaped. By adjusting the position of the float the height of the water may be varied as desired, thus increasing or diminishing the steam space and regulating the heat given off by the radiator.

Hot Weather in India.

On the 10th of May, North Sind and West Rajputana were the hottest parts of the Indian region, the maxima of temperature generally exceeding 110 deg. On the 12th idem the maxima at Jhansi and Deesa were 112.5 deg. On the 13th the highest maxima reported were 114 deg. at Deesa, and 118.5 deg. at Jhansi. On the 14th the temperature had again risen; the highest maximum was 114.7 deg. at Jacobabad. *Indian Engineering* says, "On the 15th the maximum at Jacobabad was 116.6 deg., at Hyderabad—Deccan—it was 113.2 deg. On the 16th a maximum of 116.6 deg. was reported from Jacobabad, of 115.9 deg. at Sirsa, of 115.4 at Deesa, and 114.8 deg. at Ludhiana."

ABOUT 400 barrels of crude petroleum are being turned out daily by the twenty-two wells of the Pacific Coast Oil Company in the Pico district, near Newhall, Cal. The wells of the company are now sunk to a depth of from 1,600 to 1,800 feet. The oil is of the best quality obtained on the coast, and the demand for it is very great. Some of the new manufactories at San Francisco burn oil instead of coal.



M. DE LESSEPS, PROJECTOR OF THE PANAMA CANAL, AND HIS FAMILY.

The Use of Two Doors in a Trap Door Spider's Nest.
BY GEORGE F. ATKINSON, COLUMBIA, S. C.

Certain of the species of *Nemesia*, the habits of which Mr. Moggridge studied, make two trap doors to their nests, one at the surface of ground at the upper end of the main tube, the other a short distance below, at the beginning of a branch tube. Mr. Moggridge supposed the use of the branch and second door was to afford the spider a means of escape when pursued by an enemy. When chased into the main tube, the spider would go into the branch and close the door; the enemy following, and finding the main tube empty, would leave.* In my studies of the nests and food habits of *Myrmekiaphila foliata*,† I found indications that the main tube was constructed to serve as a gallery for the passage of ants or other insects, and that the branch was constructed as a real trap, in which the spider awaited the passing of an ant, when it would open the door and catch the insect. The arguments I then advanced, briefly stated, are: 1st, the nests then found were all made in places where ants had underground passages; 2d, the main tube connected with some of the ants' galleries; 3d, the trap door at the surface of the ground had the appearance of being little used; and 4th, one nest had only one door leading into a short tube. This tube opened into the floor of a broad hall of the ants' nest leading into several galleries. Near this broad hall was the opening to the surface of the ground, made by the ants, and through which the spider probably entered the hall to construct her "branch tube" in the floor.

In May, 1888, at Chapel Hill, N. C., I found a nest of *Myrmekiaphila foliata*, under conditions which seem to give conclusive evidence that the main tube is intended to entrap unwary insects, that they might be "gobbled in" as they pass the door of the branch where the spider remains. The nest was made in a broad foot-path, where the clay soil was very hard. I discovered it by seeing the open door. The following day I visited the place with trowel in hand to dig up the spider. I found the door still open. The main tube was about nine inches long, the branch about one inch long, and was situated six inches from the surface of the ground. In this I found the spider. The door to the branch was a cork door, while that at the surface of the ground was a wafer door. It appears in cases where the nest is not made in an ants' nest, that the outer door is set open, thus offering an attractive place for insects that are crawling on the surface of the ground in search of food. They enter the main tube, and as they pass the branch the door is suddenly thrown open, and to their surprise they are taken captive and made a meal of by the cunning spider.—*Psyche*.

AN IMPROVED VEHICLE CURTAIN.

A curtain for top carriages and similar vehicles, which can be quickly adjusted to close in the top, and raised completely out of the way when not needed, is shown herewith, and has been patented by Mr. John H. Shaubach, of No. 281 Livingston Street, Brooklyn, N. Y. Close to the top of the window openings on each side, between the successive roof-supporting posts, is journaled a guide roller, a similar guide roller being journaled on each side of the central longitudinal roof brace, while a spring winding roller is also journaled to brackets on the cross braces between each two guide rollers, as shown in Figs. 1 and 2. A flexible curtain or shade, having its inner edge stiffened, is connected at

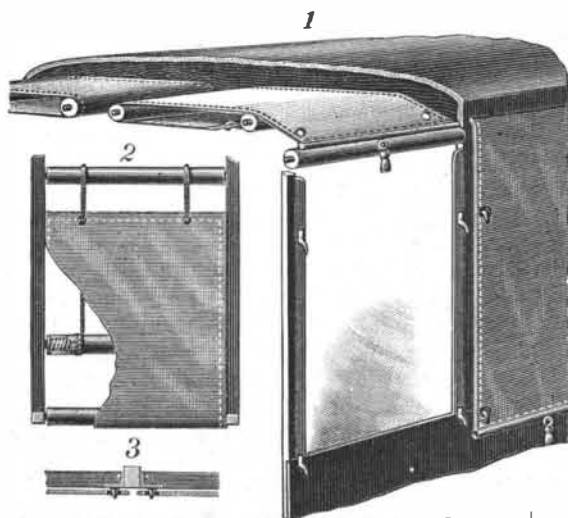

SHAUBACH'S VEHICLE TOP CURTAIN.

one end by cords to the spring roller, the other end of the curtain being passed inward around the inner guide roller, and outward over the outer guide roller, between the latter and the edge of the roof. The spring roller will normally draw almost the entire curtain up beneath the roof, but so that it will be held in position to be seized for lowering in opposition to the tension of the spring. The opposite side edges of the

* Harvesting Ants and Trap Door Spiders.
† Entomological Americana, Oct. and Nov., 1886.

curtains have eyes to receive downwardly projecting hooks fixed to the posts at the side, as shown in section in Fig. 3, to hold the curtains down, they being automatically rolled up by the spring roller when released from the hooks.

AN IMPROVED VEHICLE SPINDLE.

A vehicle spindle designed to fit always snugly in the bearing without any play, thus causing the wheel to last longer, and preventing noise, is illustrated herewith, and has been patented by Charles V. Moore, M.D., of Fairmount, Ind. The axle has a collar from which extends a conical spindle, which has a straight extension, screw-threaded on its outer end, as shown in Fig. 2. The axle collar fits into a recess on the inner end of a bearing, to be secured to the hub of a wheel, the conical spindle fitting into a corresponding opening in this bearing, while the further extension of the axle passes through a sleeve, conically shaped on its

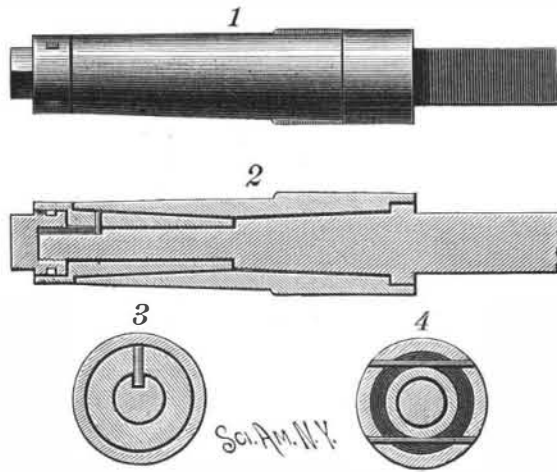

MOORE'S AXLE SPINDLE AND BEARING.

outside, and fitting into a similarly shaped opening in the bearing. The sleeve extends with its small end to within a short distance of the small end of the conical spindle, and near the outer end of the small portion of the axle is formed a groove into which extends a pin secured to the sleeve, as shown in cross section in Fig. 3, so that the sleeve is prevented from turning. On the outer threaded end of the axle screws a nut extending into a recess in the enlarged end of the sleeve, this enlarged end abutting against the outer end of the bearing. On the nut is an annular recess through which pass pins held in the end of the sleeve, as shown in Fig. 4, to hold the nut in the sleeve for convenience when removing the wheel. The sleeve is thus held by the nut in a snug position in the bearing, all wear on the sleeve and spindle being taken up by adjusting the nut on the threaded outer end of the axle, so that the spindle always fits its bearing.

A Noiseless and Smokeless Locomotive.

At Palmyra, Wis., about forty miles northwest of Milwaukee, there may be seen to-day a new, small locomotive engine (but large enough to draw several street cars), the construction of which is so different from anything which has preceded it as to be a genuine surprise to the man of science as well as to the practical engineer. Except the noise of its wheels moving upon iron rails, it is noiseless and smokeless. The fuel, any kind of wood or coal, is perfectly consumed. The steam, after use in the engines, is condensed in a new manner, and the water at the boiling point is reused. The performances of this remarkable piece of mechanism are so startling as, naturally, to cause a statement to be received with incredulity by those who have not witnessed them. To see and experiment with a locomotive which starts, stops, and reverses its direction of movement so silently and easily that, if your eyes are closed, you cannot detect the instant when the direction of motion is changed is a strange experience, and tells more plainly than words that the phenomenon before you may mark an era in the history of engines and motors. The objections to the ordinary locomotive which I have enumerated above are all overcome in the new engine. The rigid bases and all the shocks incident to a rough and uneven track are absent. All the wheels of the new locomotive are drive wheels and all its weight is traction weight. The necessity for a front guide truck does not exist, the drive wheels being so arranged as to give them easy control of the car on curves and on uneven tracks.

The most surprising feature of this locomotive is that there is very little waste of steam, heat and water in operating it, as the steam is not thrown away after using, but the water of condensation is returned to a high pressure boiler and reused over and over again with but small loss of heat. The noise incident to a forced exhaust, common in the old system, is done away with here. The combustion of fuel is so complete that no smoke exists. The side motion and jarring felt in the ordinary engine is done away with, and stopping and starting and reversing the motion of the engine are very easily accomplished.

This engine runs equally well in either direction.

One supply of water and fuel is sufficient for half a day's run or even a longer run. Nothing is wasted, which means an economy in operation never before approached in this class of machines. In answer to the claim made that it is very difficult, if not impossible, to pump boiling water, I can only say that this is easily done in this engine every day, as any investigator can see for himself.

I have purposely avoided going into details of a technical nature, my object being to state results only. The advantages of this new locomotive over the ordinary one are many and revolutionary in their importance. It need not be much more than half as heavy as the present ordinary locomotive engine, and the cost of operating it is so much less as to astonish engineers. Noiseless, smokeless, and cinderless, it can be used in the crowded streets of cities without objection and with none of the disadvantages of the common grip car. The inventor is Mr. T. T. Prosser, of Chicago, who is widely known as a mechanical expert and engineer. The Palmyra Manufacturing Company are engaged in building a second locomotive of this type, which may be exhibited in Chicago and New York. It seems to mark an era of great advance in the uses of steam, and nothing which the last half century has seen in this line has attracted the attention which will be directed to this new locomotive the moment its remarkable features are fully made known to the mechanical and industrial world.—*Duane Doty, in Railway Age*.

Palace Cars for Hens.

One of the latest improvements in the transportation of poultry is a patent palace car on the Lackawanna Railroad, designed for the conveyance of live fowl. According to the *Railway News*, the car is two feet higher than the ordinary freight car, contains 116 compartments, each one four feet square, in a series of eight decks, with an aisle running through it cross-wise and another one lengthwise. The capacity of the car is from 3,500 to 4,500 fowls, according to the season of the year. By a system of drop decks the fowls are loaded and unloaded at the bottom of the car, the sides of which are of strong wire netting, in which are the doors to the several compartments. On the top of the car in the center is a water tank large enough to supply a full load on a journey of 2,000 miles. Each compartment is supplied on three sides with abundant food and water, by a system of troughs and hose that is easily worked on the inside, no matter how great a speed the train may be going at. The food is carried in a box or tank beneath the car.

AN IMPROVED FEED TROUGH FOR STOCK.

A convenient receptacle from which dry or wet feed may be fed to stock, and which can be easily kept clean, and the contents protected from dust and the weather, is illustrated herewith, and has been patented by Mr. William Andrus, of Reedsburg, Wis. The side pieces of the main feed hopper are tenoned or otherwise secured in standards which constitute the ends of the hopper, in which there is a partition, the lower ends of the hopper side pieces converging, and being elevated a distance above the bottom of the trough, as shown in Fig. 2, the main feed hopper having hinged lids adapted to conjointly cover its entire top. With this construction, the dry feed placed in the hopper is supplied to the trough only as consumed. Adjoining the main feed hopper and trough is a compartment

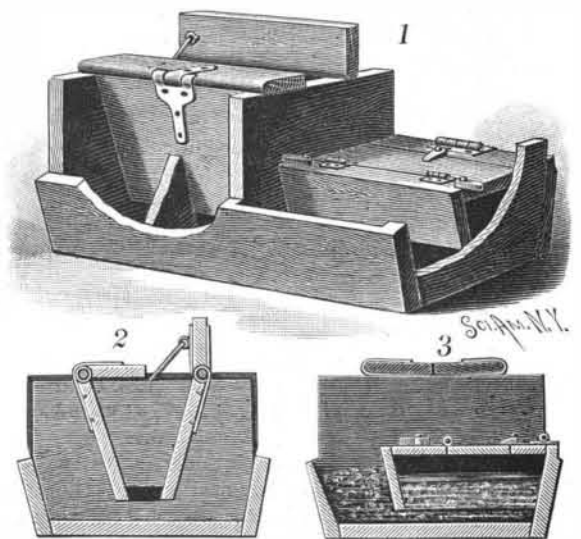

ANDRUS' FEED TROUGH.

adapted to be utilized for wet feed, and especially designed for feeding swine, the construction of which is shown in Fig. 3. The shape of the box, and a central partition therein, are designed to effectively prevent the swine from introducing foreign matter into the bulk of the feed or wallowing in it.

APPLYING kerosene with a rag when you are about to put your stoves away for the summer, will prevent them from rusting.