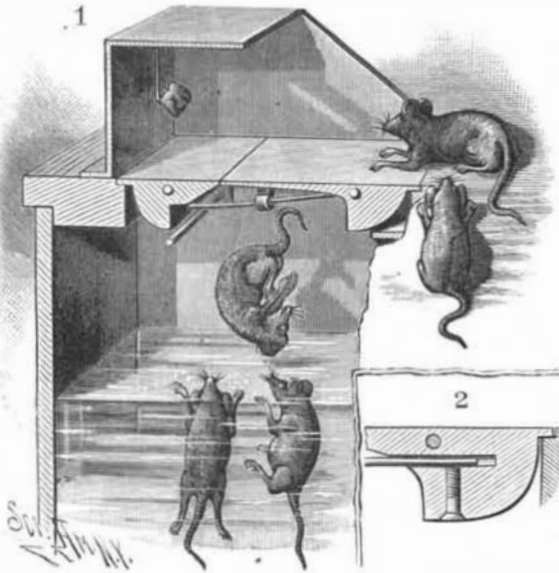

AN IMPROVED TRAP.

A trap designed to catch an animal and drop it out of sight, and which will automatically reset itself for the next animal, is illustrated herewith, and has been patented by Mr. John T. Moxley, of Owosso, Shiawassee County, Mich. It consists of a bottom board or

**MOXLEY'S ANIMAL TRAP.**

floor, preferably placed on top of a vessel holding water, a tip board and trip block being pivoted in an opening in the floor. The tip board is made longer than the trip block, and the outer ends of both the board and block are counterweighted. The detent consists of a latch fitted in a horizontally ranging socket in the tip board, and held by a screw, as shown in Fig. 2, its outer end being held by a bearing on the under side of the board to fit into a notch in the side of the trip block catch, the arrangement being such that the tip board will remain firm until the animal touches the trip block, when, be the touch ever so light, both the block and board will turn on their pivots, and the animal must fall through into the water. The gravity of the heavy ends of the tip board and trip block causes them to immediately reset themselves to normal latched positions, ready for the next animal.

Fractional Currency.

The House of Representatives has passed a bill to authorize the issue of fractional paper currency in denominations of 10, 15, and 25 cents, when demanded from the Secretary of the Treasury. This will be welcomed by the public as a great convenience in the transmission of small sums of money by mail. It is found in practice that the postal note system now in vogue is inconvenient, as compared with fractional currency. The postal notes can only be obtained and paid at money order offices, which only number 14 per cent of all the post offices. It would add to the convenience if denominations of 5 and 50 cent pieces were printed.

AN IMPROVED POCKET WEIGHING SCALE.

A scale in which the parts are so constructed that the beam and pan may be folded down to rest within a case of such size that it may easily be carried in the pocket, is illustrated herewith, and has been patented by Mr. William R. Watt, of Somerville, Tenn. To the bottom of the case is secured a post, with which is

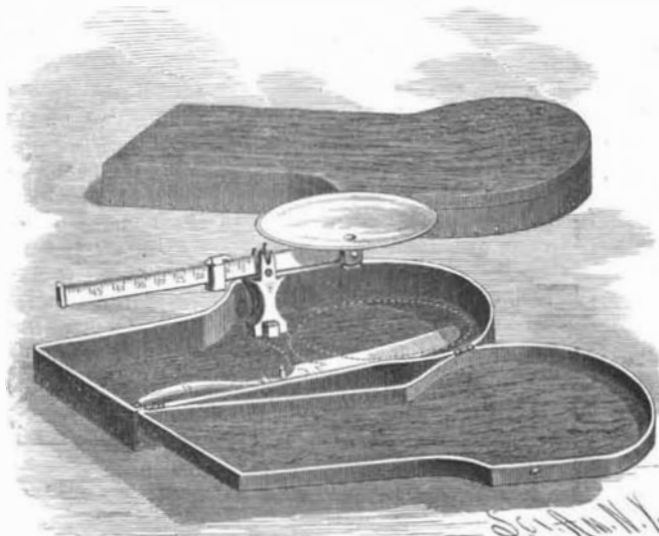
**WATT'S POCKET WEIGHING SCALE.**

connected the scale standard, by means of a pin, the lower end of the standard being slotted. The upper end of the standard is also slotted to receive the scale beam, mounted on a pivot pin, one end of the scale beam carrying a block to which the pan is secured. The pan is held in horizontal position when in use, by a spring on the under side of the beam, bearing against the block; but when the scale is to be folded within its case, a quarter turn given to the pan withdraws a

catch, and allows the pan to be folded down. A spatula is held against the rear side of the case by a post or pin, affording a handy implement for manipulating medicines, etc.

Patent Medicines.

The *Medical Record* extracts from an address of Professor Chandler, in which he says: "These firms of manufacturers of proprietary medicines, nine out of ten, live solely by the newspapers, and sometimes are admirably managed. I know some establishments in which there is a regular staff employed. I know something about them, because they try to bribe me to certify to the value of their concoctions. As I say, there is a regular staff. There is the literary man, who writes the letters, giving marvelous accounts of marvelous cures. There is the artist, who shows the patient before and after taking twenty-two bottles of the medicine; there is the poet, who composes poems upon the subject; there is the liar, who swears to what he knows isn't true, and the forger, who produces testimonials from his own imagination. Without exaggeration, I should say that nine out of ten of these proprietary medicines are frauds, pure and simple. The real business is advertising for dupes. The medical part of it is but a side issue. I am pretty sure, if I were to pound up brickbats, and spend a hundred thousand dollars in offering it at a dollar an ounce, as a sure cure for some disease which cannot be cured, I should get back at least a hundred and ten thousand dollars, thus giving me ten thousand dollars for my trouble. Nine-tenths of the medicines sent out in this fashion have no more curative properties than brickbat dust."

AN IMPROVED NUT LOCK.

A nut lock especially designed for railroad use, and which may be readily applied in connection with the ordinary fish plates, is illustrated herewith, and has been patented by Mr. John B. Crossley, of Clay Center, Kan. It consists of an angle plate of thin metal, about equal to the length of a fish plate, its height nearly corresponding to the distance between the upper face

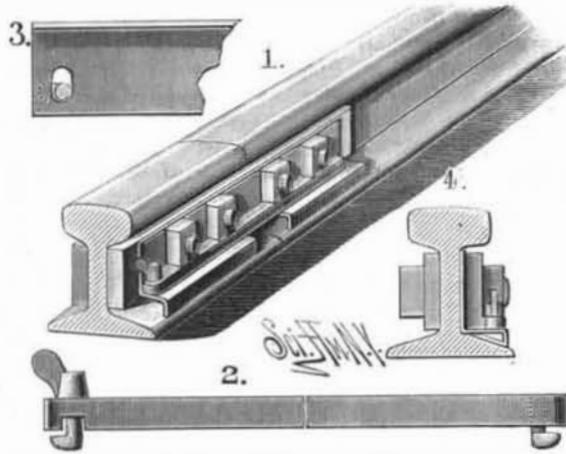
**CROSSLEY'S NUT LOCK.**

of the rail base and the under surface of the tread, Fig. 3 showing its form and Fig. 2 being a side view of the tie bar. The device is simple and cheap in construction, and can be readily applied or removed. For further particulars, address Mr. Chas. Crossley, Clay Center, Kan.

Three Sixes.

Speaking of fires in this city, one occasionally hears the remark that the alarm sounded "three sixes." Now, what is meant by "three sixes" is an enigma to most persons. It is popularly supposed it is a general alarm, and will bring to the scene of action all the fire apparatus in the city. This is a mistake. The "three sixes" are substantially equivalent to a double third alarm. *Fire and Water*, a journal devoted to the firemen's interests, explains that ordinarily a third alarm calls out an average of eleven engine companies and four hook and ladder companies. The "three sixes" sent out after a third alarm has been sent in will bring out, ordinarily, twenty-two engines, eight hook and ladder companies, two water towers, the chief, two assistant chiefs, and several chiefs of battalions. These numbers might vary a little, according to the location of the fire.

The full force of the New York City department consists of fifty-five engine companies, eighteen hook and ladder companies, two water towers, two fire boats, one chief of department, two assistant chiefs, and twelve chiefs of battalions.

An approximate idea of the amount of manganese contained in steel can be ascertained by means of the magnet. A magnet capable of lifting 30 pounds of ordinary steel or iron will only lift a few milligrammes if the metal contains 20 per cent of manganese. So small a quantity as 8 per cent of manganese will nearly neutralize the magnetic attraction.

AN IMPROVED SLEEVE STAY.

A device for holding the sleeve in place on the arm when another sleeve is being drawn over it is illustrated herewith, and has been patented by Mrs. Abby M. Terry, of No. 269 Vernon Avenue, Brooklyn, N. Y. It consists of a sleeve strap, one end of which is folded or fastened over a U-shaped hook, adapted to engage an eye or loop on the other end of the strap, there being a hand string for drawing the hook from the eye, after the sleeve is in place, whereby the strap is completely

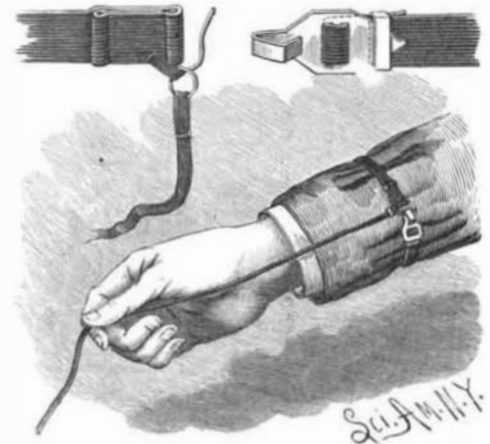
**TERRY'S SLEEVE STAY.**

loosened, and may be entirely withdrawn from the sleeve.

Train Telegraphy.

The practical value of the new system of telegraphy, by which messages can be sent from moving trains, was well illustrated by its workings on the Lehigh Valley Railroad during the recent great snow storm. In the accident near Three Bridges the induction train telegraph operator was on board, and at once telegraphed back to Flemington for a wrecking train. Within a short time Superintendent Donnelly arrived, and during the entire day messages were sent to and from the wrecking train, and surgical relief was obtained. All the beleaguered passenger trains, every one of which was equipped with the new system, were located by means of train telegraphy, and provisions were sent to the hungry passengers. Belated passengers sent dispatches to anxious wives from the various stalled trains, and all the manifold business of railroading was carried on with celerity. More than 200 messages were sent back and forth over the single line of the company during the three days of delay.

† The poles used to carry the line are only sixteen feet high, and they expose little surface to the storm. The messages are transmitted by induction from the metal roof of the car to the line, a distance of ten feet, and even when cars and line were both buried in the drifts no inconvenience was suffered, as the dry snow acted as a good insulator.

AN IMPROVED DOOR CLOSER.

A door closer of cheap and simple construction, not liable to breakage or to get out of order, has been patented by Mr. George W. Rodecap, of Middletown, Ind., and is illustrated herewith. It consists of a metal cam lever fulcrumed to the casing; in connection with

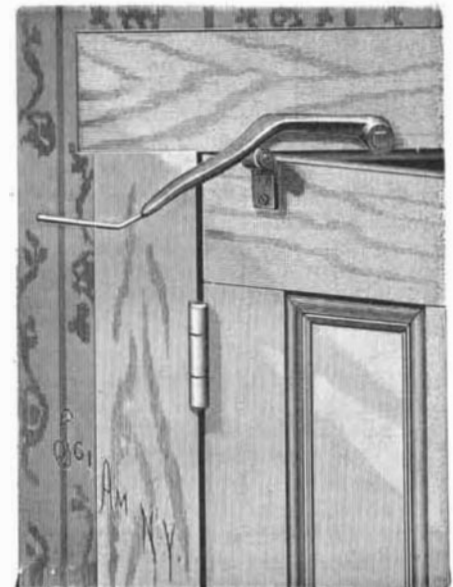
**RODECAP'S DOOR CLOSER.**

a plate piece fastened to the door, in which is journaled a roller. The lever may be weighted, to close the door automatically; but its form is such as to give a powerful leverage, which is exerted more strongly when the door is nearly closed. The device is more particularly adapted for use on doors having the face flush with the casing, and on heavy doors or gates a spiral spring may be used in connection with the lever, to increase its power.