

**SAFETY PLATFORM FOR CARS.**

The object of this invention is to provide for freight and other cars a platform at the ends near the top, for forming a continuous walk for the brakemen, in order that they may pass from car to car without danger of falling between. The support of the platform consists of an iron bar bent twice at right angles in a horizontal plane, and the ends of which enter sockets secured in the top of the end of the car, as shown in the sectional plan view, Fig. 2. Within the

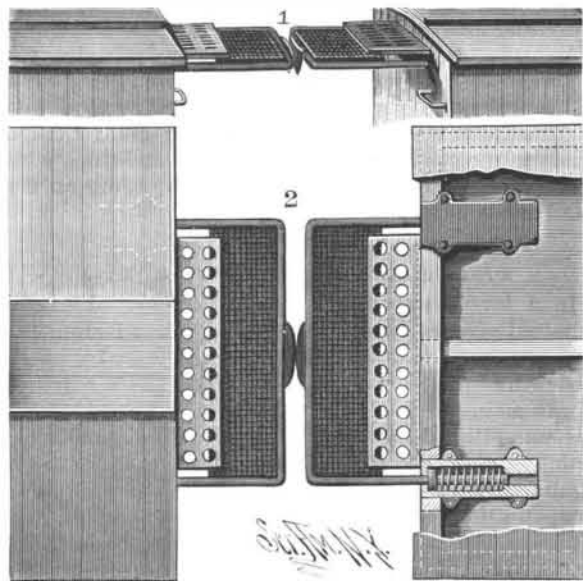

**CALDWELL & QUATERMASS' SAFETY PLATFORM FOR CARS.**

socket, upon each end of the bar, is a spring so arranged as to press the bar outward. Upon the support thus made is secured a perforated grating, forming the body of the movable platform. Secured to the end of the bar is a perforated plate, which overlaps the platform (as shown in the upper view), so that the latter may

be moved inwardly underneath the plate. To the outer edge of the frame is secured a buffer, designed to contact with a similar buffer carried by a like platform upon the adjacent car, so that when the two cars meet and are coupled, the frames and their gratings will be pushed inward against the pressure of the springs. Arranged in this way, the platforms will adjust themselves to the space between the cars, and will always close the space, so as to furnish a continuous walk for the brakeman. The platform may be made narrow, as illustrated, or it and the plate may be provided with hinged extensions, which will normally rest so as to form a walk the full width of the car; but when it is desired to climb to the top of the car, the extensions can be folded over on to the parts to which they are hinged. It is evident that the frame can be bent, to raise or lower it, so as to suit cars of different heights.

This invention has been patented by Messrs. S. H. Caldwell and R. Quatermass, of Moline, Kansas.

HERR SCHILLER, a well known German architect, reports some facts which are of interest, as indicating the radius of the circle of protection of good lightning rods. On June 17 last, at the village of Mottingen, lightning struck a pear tree 33 ft. high. On one side, 115 ft. away, was a schoolhouse, with a rod 6 ft. high. On the other side was a church, 328 ft. away, and having a lightning rod reaching up 154 ft. Both rods are well placed, and had worked well when tested, and the level of the foot of the tree is about the same as that of the two buildings. It is evident, then, if the facts have been accurately reported, that the radius of the circle of protection is not more than twice the height of the rod.

**SYMINGTON'S EARLY ROAD LOCOMOTIVES.**

William Symington, the engineer, who is generally acknowledged to be the inventor of the first successful steamboat, was born at Leadhills, in Scotland, in 1763. His father was a practical mechanic, who superintended the engines and machinery of the Lead Mining Company at Warlockhead, where one of Boulton & Watt's pumping engines was at work. Young Symington, like Murdock, was placed under his father's tuition in the North Country workshop, and, like Murdock also, he gave early proof of his ingenuity. He appears at the age of twenty-one to have conceived the idea of applying the steam engine to the propulsion of carriages. His father and he worked together to carry the idea into effect, and by the year 1786 they succeeded in completing a working model of a road locomotive. So efficiently did the model work, that those who saw the machine expressed such favorable opinions respecting it, that the difficult problem of moving carriages on the highway by steam power appeared to be within measurable distance of being solved, and Symington was warmly urged to carry his experiments to a practical issue. Mr. Meason, the manager of the lead mine, "was so pleased with the model, the merit of which principally belonged to young Symington, that he sent him into Edinburgh, for the purpose of exhibiting it before the professors of the university and other scientific gentlemen of the city, in the hope that it might lead in some way to his future advancement in life." Moreover, Mr. Meason, who proved to be his patron and friend, allowed the model to be exhibited at his own house, and invited many persons of distinction to inspect it, and he liberally offered to defray any expenses which might be incurred in carrying the invention out in practice. The state of the roads, and the difficulty which at that time existed of procuring water and fuel, afforded sufficient reasons to induce Symington to conscientiously abandon the scheme, which, through these causes, he believed, would only have produced disappointment to his kind advisers. By referring to the illustration below of Symington's locomotive, it will be seen that it

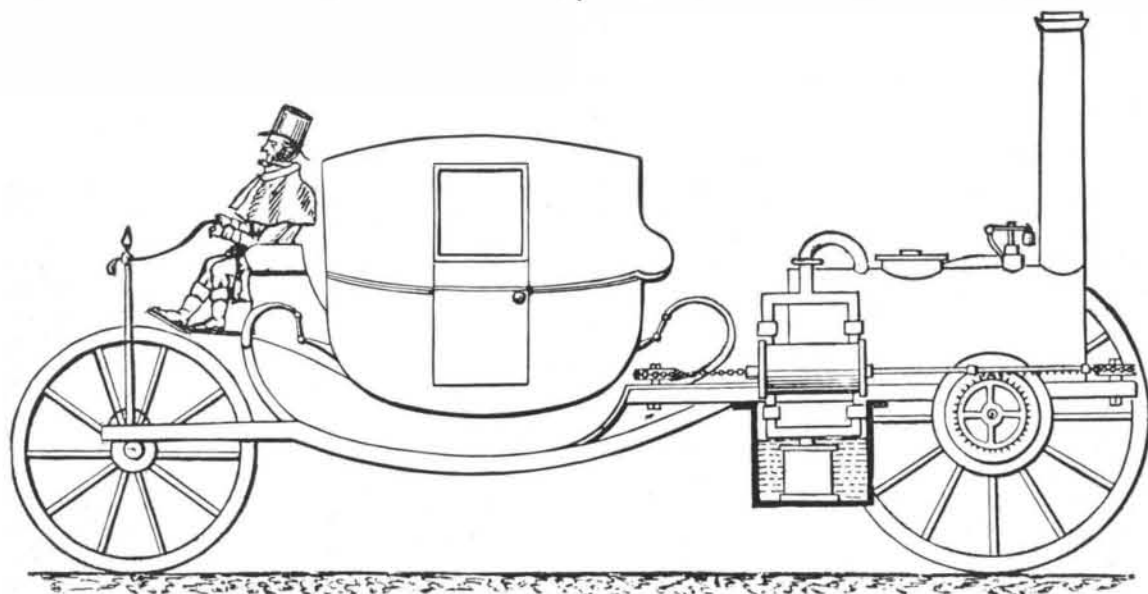

**SYMINGTON'S ROAD LOCOMOTIVE, 1786.**

consisted of a carriage with locomotive behind, supported on four wheels, the front wheels being arranged with steering gear. A cylindrical boiler was used for generating steam, which communicated by a steam pipe with the two horizontal cylinders, one on each side of the fire box of the boiler. When steam was turned into the cylinder, the piston made an outward stroke; a vacuum was then formed, the steam being condensed in a cold water tank placed beneath the cylinders, and the piston was forced back by the pressure of the atmosphere. The piston rods communicated their motion to the driving axle and wheels through rack rods, which worked toothed wheels placed on the hind axle on both sides of the engine, and the alternate action of the rack rods upon the tooth and ratchet wheels with which the drums were provided produced the rotary motion. Symington stated that a material advantage obtained by the mode here employed of applying the power of the engine was that it always acted at right angles to the axle of the carriage. The boiler was fitted with a lever and weight safety valve, and as a whole the arrangement of the engine and carriage displays much ingenuity; but we fear that the rack rods would prove unsatisfactory, while the traveling speed must have been very slow indeed. Symington's road locomotive was allowed to slumber, never to have an awakening, while the inventor turned his attention to the propulsion of vessels by steam.—*Industries.*

*The Marine Engineer*, London, says that F. Schichau, extensive shipbuilders, at Elbing, Prussia, have built and have now on the stocks one hundred and fourteen torpedo boats.

**CLOTHES RACK.**

This clothes rack is secured to the inner face of the door of an ordinary wardrobe, and consists of a vertical supporting strip, the rear edge of which is recessed and held to blocks attached to the door by screws. To the strip is hinged a rectangular frame consisting of vertical and horizontal pieces, the latter being provided with hooks on each side. Attached to the inner face of the outer strip by an elastic band or

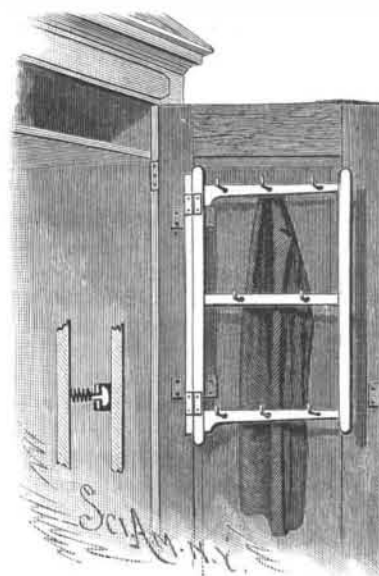

spring is a button, shown in the small view, arranged to engage with a socket secured to the door and formed with a centrally slotted arm. The clothes being hung upon the hooks, the frame may be held in a position parallel with the door by bringing the button into engagement with the socket. The frame may be swung open by releasing the button. When the device is to be used as an independent piece of furniture, the blocks are screwed to any available support. In this case a curtain should be arranged above the rack, in order that all dust may be kept from the clothes.

This invention has been patented by Mr. James S. Marsh, of Portsmouth, Ohio.

**Quality, Not Quantity.**

In reply to a letter of inquiry addressed from the *Industrial World* to the Washburn & Moen Manufacturing Company, of Worcester, Mass., they send the following, which embraces so much good advice, applicable to all lines of industrial pursuits, that we take pleasure in transferring it to our columns:

"If manufacturers in all lines of goods would have faith enough in themselves, and in the markets of this country, which are unequaled, and would pay more attention to the quality of their goods and the economies possible in manufacturing, and less to the mere work of getting rid of their goods without much regard to price, a very much healthier condition of things would obtain throughout the whole country. Every manufacturer of a staple line of goods in a fairly good location is insured a fair profit from his business by the extent of the American market, and nothing but unreasoning and precipitate competition can effectually neutralize this wonderful and perpetual condition of things, *i. e.*, the extent and reliability of the American market for any and all staple goods."

**IMPROVED STUFFING BOX.**

The annexed engraving illustrates a stuffing box which is the invention of Mr. C. P. Wetherill, of Woodville, Miss.

The gland of the stuffing box is composed of two separate and distinct parts, A B. The part, A, is an outer flanged plate, and the other part is a ring, b, provided at one end with a flange, c, the outer surface of which bears against the inner face of the plate, A. The part, B, is of sufficient interior capacity to contain the packing, which, surrounding the piston rod, C, is compressed against a neck, e, upon the cylinder head when the gland is forcibly held down to its place by the stud bolts, f, screwed into the cylinder head. The collar portion, b, is held against the plate, A, by clips or headed bolts, g, projecting from the back of the plate and entered, when the collar is properly turned, through recesses, h, in the flange, c, of the collar, so that on turning the collar back again to its normal position, with the recesses out of line with the bolts, the heads of the bolts will engage with the inner face of the flange, and lock the parts, A and B, together. This construction of the stuffing box greatly facilitates the insertion and removal of packing when required, especially in contracted and awkward places.

