

INSTRUMENT FOR OBTAINING LENGTHS AND BEVELS OF RAFTERS.

This instrument consists of a rectangular frame, A, hinged to which is the board, G, and the straight edge, H, and attached to which is the protractor, E. These parts are arranged and graduated as shown in the engraving. The instrument is used for obtaining the length of rafters—for instance, for a building 8 feet wide—by placing a square on the graduation, *b*, at 4 feet, which is the distance from the center of the building to the outside, and adjusting the board, G, to the desired pitch of the roof on the protractor, E. Where

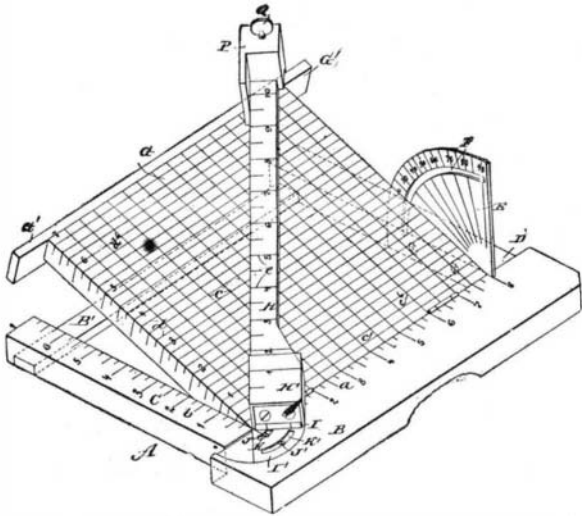

CONLEE'S INSTRUMENT FOR OBTAINING LENGTHS AND BEVELS OF RAFTERS.

the square touches one of the lines, *d*, on the board, the distance from there to zero indicates the length of the common rafter; and by following the respective line, *d*, across the board to the straight edge, which is set say at 45°, then the intersection of the lines, *d*, at the graduation, *e*, of the straight edge gives the length on the scale, *e*, of the hip rafter. By following the line, *c*, which intersects the line, *d*, and scale, *e*, down to the scale, *a*, then the latter indicates the length of the jack rafter. The instrument is also adapted for accurately and quickly obtaining the bevels for jack, common, and hip rafters, and for obtaining the bevel across the face of the staff for splay or hopper work, and also the miter across the edge of stuff for splay or hopper work.

This useful instrument is the invention of Mr. Harrison Conlee, of Petersburg, Ill.

ORE CONCENTRATOR.

The object of this invention, which has been patented by Mr. John D. Channell, of Nevada City, California, is to provide an ore concentrator simple in construction, and which will effectively concentrate the heavy and light particles of the precious metals. The main driving shaft extends along one side of the machine, and at each end is provided with a beveled gear engaging with a similar gear on an upright shaft. At the upper ends of these shafts are cranks and pins, to which are attached rods securely fastened to the frame carrying the belt. The belt frame hangs on four swings, and is easily given a rotary motion. At the lower ends of these swing rods are screws, whereby the belt frame can be adjusted up or down, so as to bring the belt perfectly level. There are four large and twelve

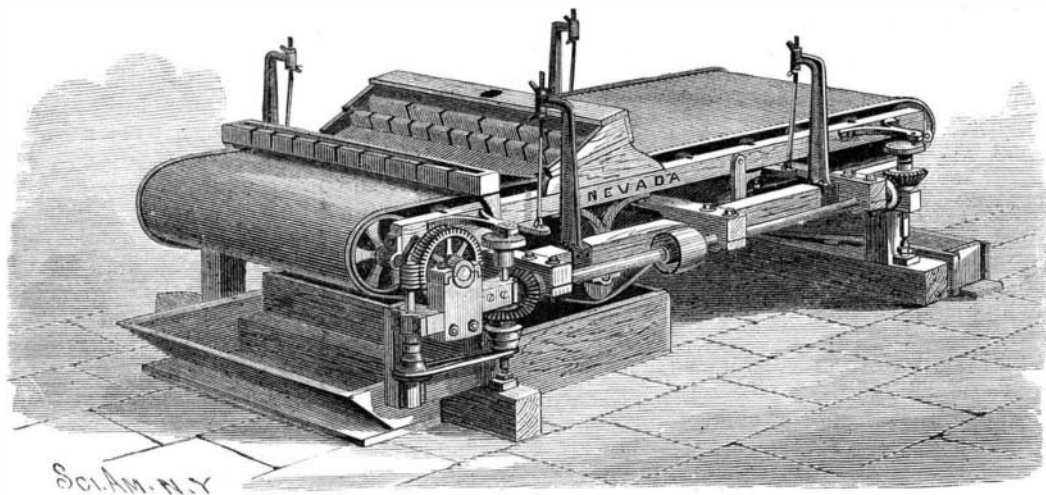

CHANNELL'S ORE CONCENTRATOR.

small rollers over which the belt travels. The one at the head of the machine drives the belt by means of a screw gear and vibrating connection. The next roller carries the belt down into a box containing water, where the gold and other metals are washed off. The next roller acts as a tightener and also raises the belt higher than the end one, so that the sand and water will not run back under the machine. The fourth large roller is at the rear of the machine. The twelve small rollers are placed under the belt on top of the frame, to give a smooth surface to the belt.

The machine is run by a driving pulley placed at

about the center of the main shaft. The feed gear is worked by means of a belt on cone pulleys, as shown in the engraving.

The pulp or sand from the battery is delivered to the machine through a hole in the center of the distributor, and is spread evenly over the belt. The water distributor on the front furnishes an extra supply to more effectually wash out the sand.

Each edge of the rubber belt is provided with a rubber tube or hose, of such size as to prevent the water and sand from running off. This construction insures durability, as the flexibility of the belt allows it to easily pass over the rollers without danger of breaking.

It will be seen that this concentrator is simple in construction, and does not require a thoroughly experienced person to operate it. The easy rotary motion of the belt carries gold sulphurets and all heavy metals to the bottom, and holds them there while the sand is washed away. As this rotary motion is smooth and continuous, the belt can be run faster than in those machines having a vibrating movement, while it washes the sand away quicker and saves lighter and finer dust. It also requires a minimum amount of power to work it. Tests have shown the advantages of this machine in the quantity of metal saved, the rapidity of its operation, and small power required.

RAILWAY TRACK SYSTEM.

The object of this invention is to obviate, by means of a simple and efficient system of railway track construction, the difficulties which arise in maintaining the rails of a track, as ordinarily constructed, in proper surface and to correct gauge. The ends of the main rails are turned outward where splice rails are laid, as represented in Fig. 1. The splice rails are beveled at the ends, so as to lie closely to the inner sides of the main ones, and form therewith continuous rails, and are located at places where the accumulation of the "waves"—which cause "creeping"—in the rails would reach a dangerous limit, as at crossings at grade, at the base of heavy inclines, and at frogs and draw bridges. The ends of the main rails are set close together, no separation being made to allow for expansion, as in the usual construction, and are connected by fish plates which do not allow for lengthwise movement of the rails. The spikes are not driven as far as possible, a space of about half an inch (Fig. 4) being left between their heads and the rail flanges, which are not notched to receive the spikes. The splice rails have notches in their flanges through which spikes are driven so that their heads

may be compressed by a properly arranged screw. The recess of the grip is a little wider than the rail base, so that, when the pin is forced inward by the screw, the grip will be turned to cause diagonally opposite edges to clasp the rail and prevent its backward movement, while allowing a forward movement. To release the rail for any purpose, the recess in the

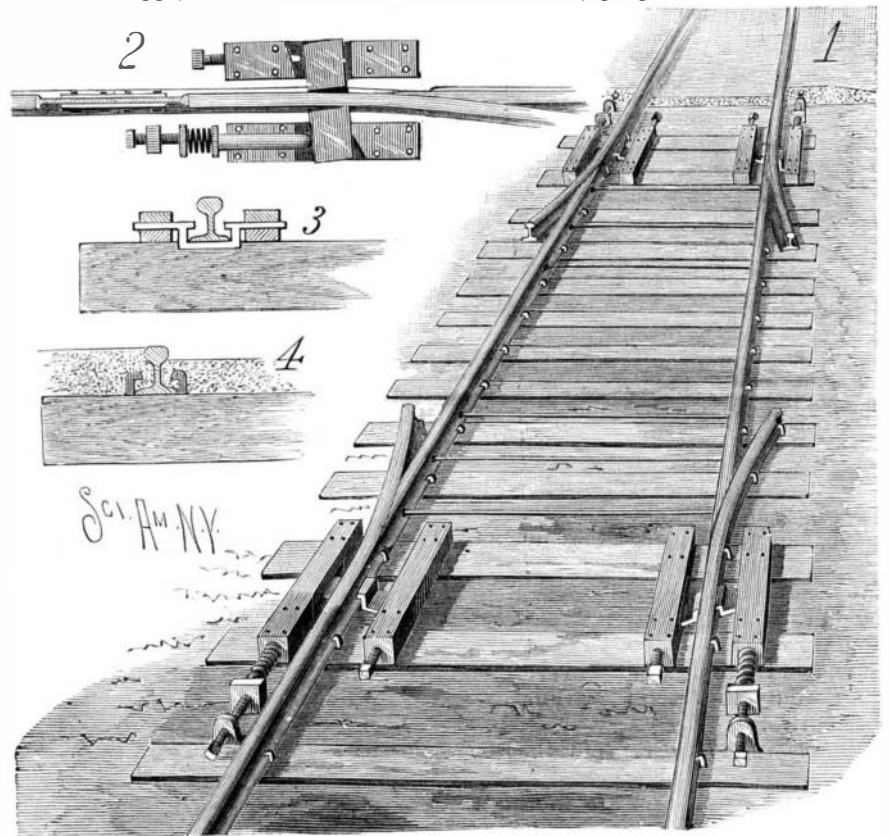

NOONAN'S RAILWAY TRACK SYSTEM.

grip can be brought about parallel with the rail by properly turning the screws. The ties are entirely covered with dirt, as shown in the background of Fig. 1. This covering does not interfere with the lengthwise movement of the rails, while it holds the ties solidly in the roadbed. Although this system is especially intended for use with dirt roadbeds, it may be adopted when the ties are ballasted with sand, stone, or other material.

This invention has been patented by Mr. Philip Noonan, of Edgard, La.

RIVETING TOOL.

The construction of this tool is very clearly shown in the figure herewith presented. On one end of the shank or body portion is a punch about the size of an ordinary copper rivet, and on the other end is a suitable boss to receive the blows of a hammer. One end of the head piece has a concavity shaped to give a proper form to the upset end of the rivet, and at the other end is a boss for striking upon. To use the tool, the parts to be united by rivets are first pierced by the punch, when the rivet is inserted and the usual washer put on. The projecting end of the rivet is then placed in the hole in the shank of the tool, when the stroke of a hammer forces the washer down tightly to the work. The concavity is then placed over the end of the rivet, which is then upset and given a neat convex finish by blows delivered upon the opposite end of the head piece. The punch may be made removable, and the hole in the shank may be formed in a removable sleeve, to adapt the tool for use in setting rivets of various sizes.

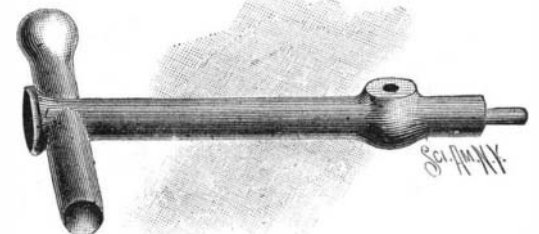

STEVENS' RIVETING TOOL.

This handy riveting tool is the invention of Mr. James H. Stevens, of Grover, Col.

ALUMINUM TIN.

The applications of aluminum are now considerable, and M. Bourbouze, a French physicist, has added to their number by employing an alloy of the metal with tin for the internal parts of optical instruments in place of brass. The alloy he employs consists of 10 parts of tin and 100 parts of aluminum. It is white, like aluminum, and has a density of 2.85, which is a little higher than that of pure aluminum. It is, therefore, comparatively light, which is an advantage for apparatus where lightness is desired. It can be soldered as easily as brass, without special means, and it is even more unalterable than aluminum to reagents.