

sacks of flour per day. The engine was exhibited *hors concours*—that is to say it did not compete for a prize, and was sold to MM. A. & N. Buysse, millers, of Wetteren.

The cylinder is carefully jacketed, and the valves are all worked by cams on a horizontal shaft driven by bevel gear. The exhaust valves are of the grid-iron type. The steam is actuated by double beat puppet valves, as shown in the cross section. The trip gear is extremely simple. A detent actuated by a spring engages with a vertical rod. The detent is carried by a frame, which is lifted by the cam on a rotating shaft. The vertical rod is provided with an arm, to which is secured the valve rod. The governor controls an inclined lever, on the end of which is a toe. This toe comes in contact with the trigger of the detent before referred to, and pulls it down as soon as the frame has reached a given height, or more strictly, it prevents the trigger from continuing to rise with the frame. This pulls the catch out of the vertical rod, and allows the valve to drop and so close. The angle of inclination of the toe-carrying lever is settled by the governor, which thus controls the ratio of expansion. An examination of the cross section through the cylinder will make this quite clear.

The engine exhibited at Antwerp furnishes another example of the great perfection to which Belgian engineers have carried the art of steam engine construction.

**The Inaccuracies of Car Wheels.**

At a recent meeting of master car builders at Boston, Mass., it was stated that the 24 inch chilled iron car wheels were liable to be  $\frac{1}{4}$  inch different in ranges of diameter and an equal amount in eccentricity, both variations being caused by irregularities in cooling. The sentiment of the meeting was reported to be against grinding the wheels to accuracy in concentricity and diameter, as involving a useless expense. These opinions do not seem to be warranted by an examination of the facts. The evils of uneven wear of chilled wheels are well known, and universally ascribed to skidding the wheels by excessive application of the brakes, but as such use of brakes is forbidden, and at present somewhat infrequent, is it not more probable that it is in great measure due to the enforced slip caused by fastening wheels of different diameter upon the same axle? Taking the extreme case of a 24 inch wheel and a  $24\frac{1}{4}$  inch wheel upon the same axle, in a 100 mile run there would be a difference of 871 revolutions, or 5,529, feet in the distance compassed by each of the wheels, and one wheel or the other must have slipped on the track more than a mile, with its consequent wear, which would soon find the softest parts in the wheel, not to mention the excess of tractive force required to do this extra work. Such of the wheels as were  $\frac{1}{4}$  inch eccentric would be raised 1,751 feet during the 100 mile run; and the one-third of a mile of vertical component must pound rolling stock and roadway. Some of the best managed American railways use, on their passenger cars, wheels which have been ground, but this comprises only a small proportion of all the car wheels in use. The Pullman parlor cars use wheels which are made of an annular mass of paper, 36 inches in diameter, pressed between an iron boss at center and surrounded by a steel tire; thin iron plates bolted to each side protect the paper against exposure. There are other forms of car wheels made of pieces of iron with rubber between the iron body of the wheel and the steel tire, and they have given excellent results, but the excessive first cost has retarded their introduction.

A THICK vein of coal was struck at a depth of 245 ft. near Chatham, Ill.

**Electrical Swords.**

The recent production of the play of "Faust" at the Lyceum Theater, London, called to its assistance, besides the charming acting of Mr. Irving and Miss Terry, the scenic possibilities of electricity in a manner never before attempted. In the duel scene between Faust

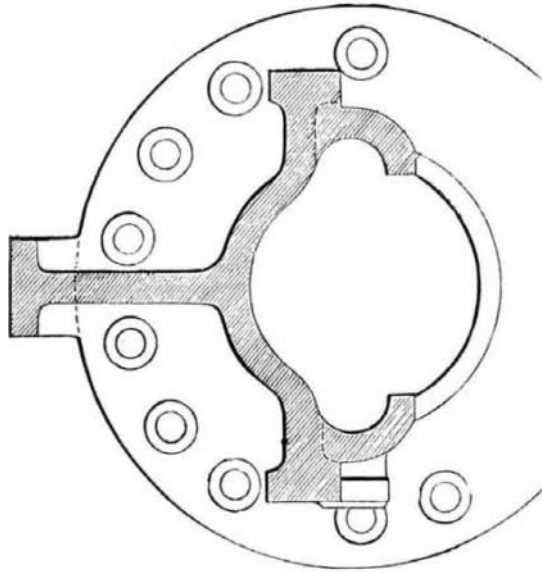

CONDENSING ENGINE.—CROSS SECTION OF FRAME.

and Valentine, Mephistopheles takes a sinister part; and each time that he crosses his sword with that of Valentine, there is a flash of fire, a continuous blaze of electricity. The combatants have a metal plate under foot connected with a battery, and both Valentine and Mephistopheles have metal soles to their shoes, connected by a wire with their sword blades. As their swords touch, an electric circuit is completed. The continuous discharge of electricity is caused by the edge of the weapons having teeth like a saw, each of which gives off its spark. Faust is not a "conductor," and consequently his sword is harmless.

**DESIGN FOR AN OBSERVATORY TOWER.**

Our engraving shows the prize design for an observation tower for Heilbronn, which is soon to be erected by Messrs. Von Eisenlohr & Weigle, of Stuttgart.

The plan is the result of a universal competition. Of the fifty-four designs presented, this one drew the prize,

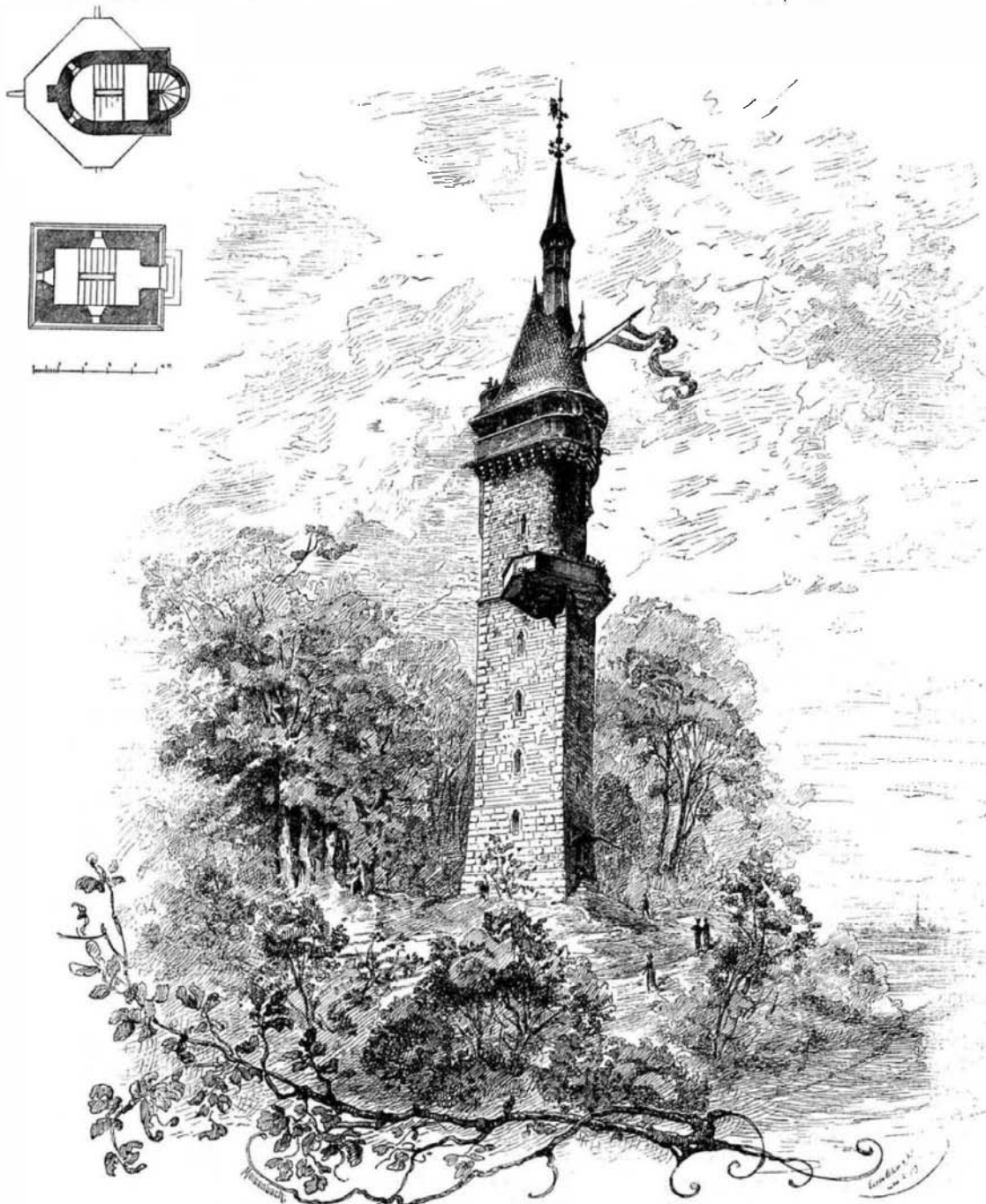

PRIZE DESIGN FOR AN OBSERVATORY TOWER.

and was recommended for execution. The programme pointed out that special attention should be given to the finish of the upper part of the tower, as it is to be surrounded by a growth of trees, 46 feet high; that a flight of easy steps should lead to the top; and that the cost of construction should not exceed 12,000 m., or about \$3,000.—*Architectonische Rundschau.*

**Bleaching Drawings made upon a Photographic Print.**

BY W. W. BODE.

Reading in one of your late issues of a method of bleaching away a photograph made on good Bristol board, after the same had been worked over by the artist, so as to admit of its being reproduced by photo-engraving processes, recalls to my mind many of the unpleasantnesses encountered in attempting to bleach drawings made upon a photographic print. The principal objection which presented itself was the dinginess or yellowness of the paper after bleaching, notwithstanding the precaution of having it thoroughly washed, and even after repeated applications of flowing with the bleaching solution made after the well known formula of about one quart absolute alcohol to one ounce bichloride mercury.

The dingy yellow brown on the paper, not permitting a strong black and white negative to be made, would be fatal to a good reproduction; if the drawing happened to be one with a large proportion of shadows, the dinginess increased proportionately, and more so where the drawing would take a couple of days or more to complete.

To remedy these difficulties I resort to the following method, which has always given me clean, white results, and is one which can be relied upon.

Procure good plain paper, salted, and float the same on a silver bath, made as follows:

- Distilled water ..... 9 ounces.
- Nitrate of silver..... 1 ounce.

Dissolve the silver in the water and separate three ounces of the solution from the rest, to which add liquor ammonia until the oxide of silver formed is redissolved and the solution is again clear. Then add it to the remaining six ounces of solution. Oxide of silver will again be formed, which can be allowed to settle to the bottom, or decant and filter same.

Give sufficient time in printing to get out all the detail, but do not print very strongly; thoroughly wash until the print becomes red (do not use warm water).

When the excess of silver has been thoroughly removed by several changes of water, place the same in freshly made hypo.; let it be rather weak and about equal proportions of hypo-sulphite of soda and good bicarbonate of soda. It should remain in this solution about ten or twelve minutes only, and not longer than that time. You desire simply to fix the image temporarily and not permanently. Thoroughly wash the same in several changes of clean water, and then mount on cardboard.

The drawing should be made as soon as possible after the paper is thoroughly dried, for, if kept several days, the image will begin to show signs of dissolution. After the artist has outlined enough for his guidance, flow on the bleaching solution as you would collodion, and in fifteen minutes you will have a pure white paper without the slightest trace of a photographic substratum.—*Lithographer and Printer.*

A PLAN for rendering paper as tough as wood or leather, it is said, has been recently introduced on the Continent. It consists in mixing chloride of zinc with the pulp in the course of manufacture. It has been found that the greater the degree of concentration of the zinc solution, the greater will be the toughness of the paper. It can be used for making boxes, combs, for roofing, and even for making boots.