

AN IMPROVED LEVER WRENCH.

A wrench especially designed for turning the nuts on fishplates is shown herewith, Fig. 1 representing the wrench as applied on the rail, and Fig. 2 giving a side view. It is so constructed, it will be seen, as to turn two nuts at the same time. The main lever bar has a slot, and on the lower end a squared recess for receiving the nut; from this bar also projects a stud or pin, and a bolt through the slot holds another lever bar, curved as shown, and having on its lower end a squared

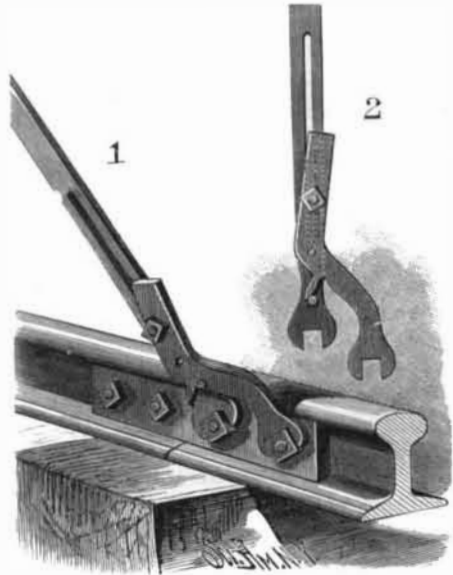

GOODSON'S WRENCH.

recess for receiving another nut. This second lever bar has a downwardly projecting lug, to engage the stud or pin on the main bar, and regulate the distance the second lever bar is allowed to drop. In operation, as the main lever bar is pushed forward, the bolt attaching the second lever bar slides upward in the slot, and two nuts are thus turned at once.

This invention has been patented by Mr. William D. Goodson, of Eufaula, Ala.

PERFORMANCE SHEETS AND RECORDING WORK DONE BY LOCOMOTIVES.

It is generally the opinion now among railroad men that the exchange of "performance sheets" is of no value. This arises from the fact that the conditions vary very materially under which these sheets are made up, and it follows, therefore, that a master mechanic who may be operating his locomotives at a total cost of 17 cents per mile is really doing this cheaper than another who is operating at 12 cents per mile. The standard of comparison of work done is the loaded car, or loaded car miles, which means the number of loaded cars hauled one mile. This is obtained by multiplying the number of loaded cars hauled by the number of miles they are hauled, the result being loaded car miles. Thus 500 loaded cars, each hauled 100 miles, is a mileage of 50,000 miles, and $500 \times 50,000 =$

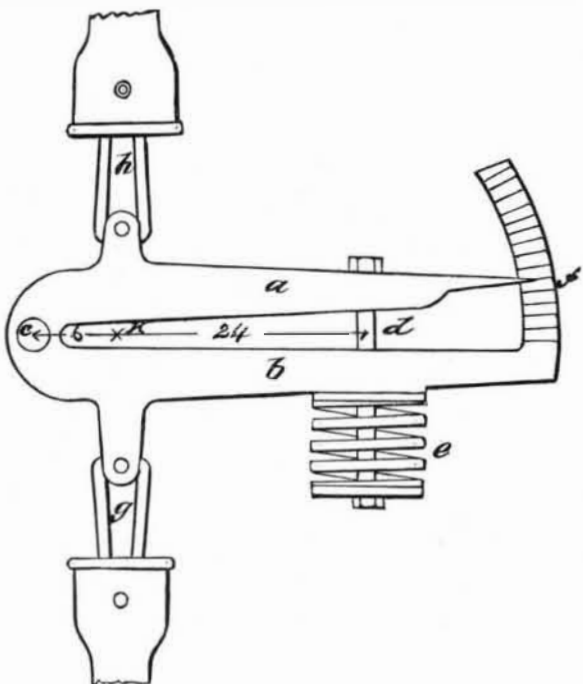

25,000,000 car miles. This form of comparison is occasionally refined to ton miles, which means the product of the weight of the cars and loads hauled in tons by the total mileage. The want of any truth or value in the comparison of the performance of engines on different roads is found in the fact that a "loaded car" may mean a load of 12, 13, 15, 17, or 20 tons. Then in the rating of empty cars, that is in reducing a mixed train of "loads" and "empties" to "loads," the same want of uniformity is found in a standard of measurement, as one road rates three empty cars as one loaded one;

other roads say five empty cars equal three "loads," or two "loads;" others, seven "empties" as three or four "loads," and thus it will be seen that a comparison on such data is worthless.

This might be refined, as before mentioned, by reducing the trains hauled to ton miles, that is, taking the weight of the train in tons (thus eliminating the factor of "empties" and "loads"), and multiplying it by the miles.

But while this result is a little nearer the truth than the other, it is not what is required, as no comparison or data is furnished of the extra work expended in hauling up grades and around curves, as it is plain that one road may be an extreme in hills and curves, while another, with which comparison is made, is as level and straight as could be wished for.

It is occasionally claimed that a hilly road is no more costly to haul over than a level road, and theoretically this may be true. But in practice there is quite a large difference, which arises from the fact that an engine slips more on a hill than level, and the loss of stored-up work in the train, obtained by hauling the train up the hill, which work is not given out to any useful end in descending the hill, as the speed of the train is controlled by the brakes, and the surplus of this stored-up work is thus ground away in uselessness against the brake shoes.

To gain or profit by the stored-up work, the train would have to be allowed to run down the hill unchecked by the brakes, a proceeding of a character which would hardly pay for the profit, in view of the dangers, etc.

The only correct basis or standard of comparison would be the foot pounds of work done in hauling a train over any road. To obtain this, the average strain on the tender drawbar would have to be obtained (unless it was desired to include the work of moving the engine). Knowing the average pull on the drawbar and the weight of the train, and assuming an average freight train speed for all roads of 15 miles per hour, and the necessary factors are at hand to make a fair comparison. To obtain this, a train of known weight might be hauled over a road at 15 miles per hour with a dynamometer placed between the train and engine, and its reading taken every one, two, or three minutes, and the average strain in pounds per ton of the load thus obtained. This would take into account all hills, curves, etc. A rude but practical dynamometer for this purpose, which the writer has used, is shown in the accompanying illustration.

Two bars of iron pivoted or hinged at C are arranged with lugs to be coupled by a link between the engine and tender at h and g. The extension of arm, a, forms a pointer moving over the arc, f, which is an extension of arm, b. A crucible steel car spring, e, abutting against arm, b, is attached by a bolt, d, to arm, a, so that when the arms are drawn apart by the pull of the engine, the spring will be compressed. As such a rig is necessarily home-made, the location of the spring, e, is dependent on its size, etc.

A crucible steel spring that has had use enough under a car to work out the tendency to "set" in new springs is the best. The spring must be capable of resisting, just before it closes completely, the entire pull of the engine. Supposing the average freight engine to be able to exert a pull of 12,000 on the drawbar, and the distance from the center of the line of draught, K, to the center of the pin, C, pivoting the arms together to be 6 inches, and the distance from K to the center of the bolt, B, to be 24 inches, then to find the resistance a spring must offer to be equal, when almost closed, to a pull of 12,000 pounds

$$\text{at } h, \text{ we have } \frac{6 \times 12,000}{30} = 2,400 \text{ pounds.}$$

Springs can be readily tested in a wheel press, or with a lever arranged across the top of the spring and weighted at its outer end. If a spring is found which nearly closes at more or less than this weight, its location or distance may be easily found to balance the supposed pull of 12,000 pounds on the drawbar by multiplying the 12,000 by the distance from the center like of draught, K, to the point, C, and dividing the product by the number of pounds the spring nearly closes at, the result being the distance in inches the spring is to be located at from the center of C. To use such a rig, it is necessary to extend the dead woods so that the extra slack given by the rig may not be injurious. After locating the spring, the arm, f, may be marked by suspending the rig from a suitable support, such as a heavy crane, and either loading the lower end, h, with car wheels of known weight, or arranging a lever to pull down at h, so that less material in weights will be necessary. Hitching a given number of cars of known weight behind the engine, with this rig, and keeping an even average speed of 15 miles per hour, and reading the indication as the arc, f, every one or two minutes, or half or whole miles, would give data for an average pull per ton for that road. This being once known, the work done by an engine in hauling any train, whether of loaded or light cars, would be easily arrived at, and justice done to many master mechanics, whose apparently high

cost per mile run would be explained by the fact that from three to five times as much work was performed by his engines.

FRANK C. SMITH.

A CAR WHEEL AND AXLE.

To afford improved means of attaching car and other wheels firmly to their axles, and so the wheel can be readily removed if desired, is the object of an invention recently patented by Mr. Joseph H. Black, of Columbia, Penn. The axle is formed with an enlarged screw-threaded collar, which is slotted to receive a key, while the wheel has a screw-threaded recess to receive the screw-threaded collar, and is slotted to correspond with the slot of the collar of the axle, to receive the key for fastening the wheel upon the axle. To strengthen the wheel, and to hold the key in place, semicircular washers are bolted to the wheel by screw bolts passing through the wheel and washers. To simplify the drawing out of the key, in case the wheel is to be removed from the axle, a passage is formed through the wheel in line with the recess occupied by the key, in which a small tool may be inserted for driving back the key.

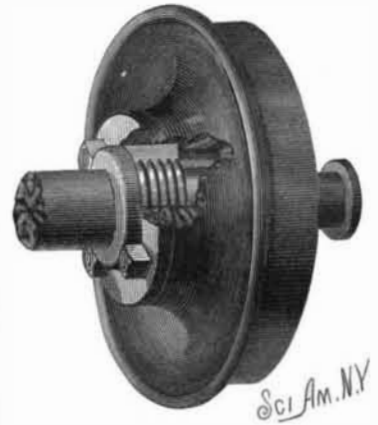

Sci Am. N.Y.

Strange but True.

This is one of the curious things floating about: Take a piece of paper, and upon it put in figures your age in years, dropping months, weeks, and days. Multiply it by two; then add to the result obtained the figures 3,768; add two, and then divide by two. Subtract from the result obtained the number of your years on earth, and see if you do not obtain figures that you will not be likely to forget.

AN IMPROVED COVER FOR LARGE BOOKS.

Usually in opening large blankbooks, and other heavy volumes, bound in boards and with stiff backs, the first few sheets are drawn back with the cover, causing strain on the threads, to obviate which difficulty is the object of the invention herewith illustrated. Fig. 1 represents a partly broken inside view of a book bound according to the new plan, and Fig. 2 a transverse section of the book open in the middle. The book proper or leaf portion is stitched and strapped together in the usual manner, but attached to the stitched portion is a stiff, or moderately stiff, slide or sliding flap, on each of its two outer sides, these slides being fitted to work freely back and forth, when the book is opened and closed, within recesses in the bound covers, these recesses extending any desired distance into the covers from their inner edges, and to within a suitable distance from the end edges. Suitable stops are provided for these slides, to limit their movement and prevent the separation of the book and its covers, one form of which is shown as a face strip arranged to work with the slides in a suitable longitudinal open-

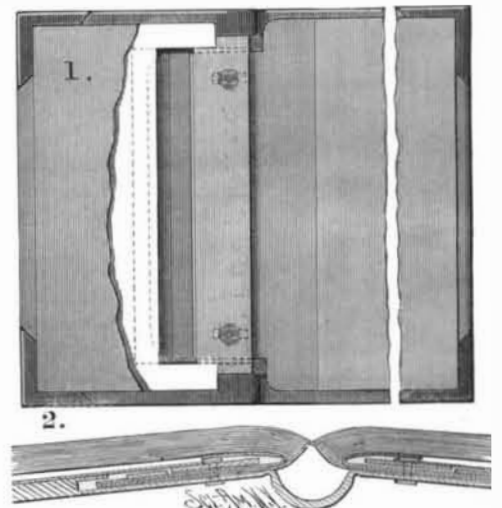

WILLIAMSON'S BOOK COVER.

ing, and if desired rivet-like fastenings may be passed through the covers to keep them from warping and to prevent the slides from being torn out. By this method of binding a sliding joint is formed at the connection of the book with the covers, so the book may be opened freely and flat without straining on the threads or binding.

This invention has been patented by Mr. Thomas F. Williamson, of No. 180 Twenty-fourth Place, Chicago, Ill.