

IMPROVED PRINTER'S CHASE.

The chase shown in the cut can readily be adjusted to fit type forms of various sizes, thus permitting its use in place of the assorted chases now necessary in printing establishments where a variety of job work is done. The chase being, practically, self-locking saves all time usually spent in filling out with furniture, quoins, etc. Fig. 1 is a perspective view, Fig. 2 is a longitudinal section through one of the sides, and Fig. 3 is a section through the central brace. The chase consists of four similar L-shaped pieces; one arm of each piece being made so as to slide over and inside the part of the adjoining piece. The inner arm is made in the shape of a double-dovetail tenon, and in the arm it slides in is a double-dovetail groove, which extends nearly to the angle and joins a horizontal hole in which works the adjusting bolt. A threaded nut, embedded at a suitable point in the tenon, receives the end of the

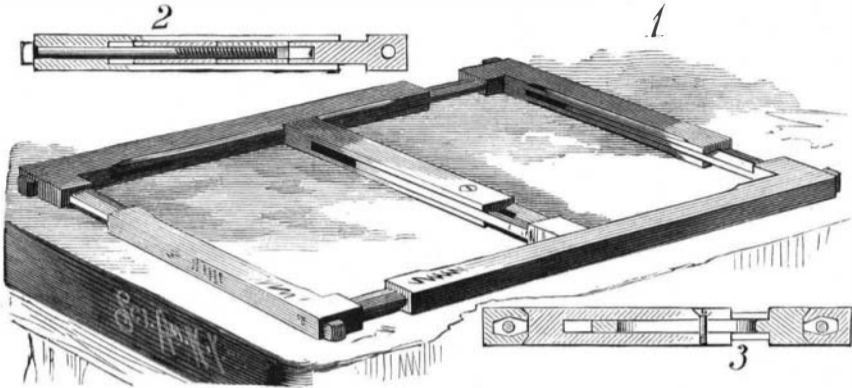

BRILL'S IMPROVED PRINTER'S CHASE.

bolt. The inner, upper and lower edges of the grooved arms are beveled, and against these edges rest the ends of the central crossbar, which consists of two pieces, the form of which is clearly shown in the engraving. The central part of the tenon piece is slotted to receive the body of the fastening screw, which passes through a hole in the other part. The adjustment of the various parts of the chase may be easily and rapidly made; the manner of changing the size will be understood from the foregoing and from the engraving.

This invention has been patented by Mr. Peter Brill, Jr., whose address is care of Mr. A. C. Pleyte, 1719 Walnut Street, Milwaukee, Wis.

AN IMPROVED SAFETY ENGINE.

The accompanying engraving represents a safety engine of novel construction, invented by Mr. Henry Davey, a mechanical engineer of prominence in England, and now being manufactured by Messrs. Charles P. Willard & Co., of 284 Michigan Street, Chicago, Ill. Although the principle involved in its construction is not new, the application and combination have not before been used in small motors. It differs from a steam engine in the fact that while a small quantity of steam is used, it is not the motive power employed to do the work, the only function of the steam being to create, by condensation, a vacuum, which constitutes the motive power. There is absolutely no pressure in the generator, and consequently there can be no danger of explosion under any circumstances. The cylinder is provided with an internal cylinder, made of bronze, which is entirely surrounded by steam. The admission and cut-off are regulated by suitable mechanism operated by the engine itself. Condensation is effected by means of a surface condenser, which is contained in a pocket shown at the rear of the engine. The air pump, which connects with the condenser, and the hot well are of special construction, and are shown attached to the side of the main frame. The water supply is regulated by a valve contained in the float box shown at the side of the generator. The entire amount of steam generated is condensed, and is discharged through a small opening at the side of the hot well in the form of hot water. The engine is double acting, steam being condensed at both ends of the stroke, so that a vacuum is produced alternately at each side of the piston head. The water level of the engine is constant and unvarying, and the quantity of water actually consumed is so small as to remove all difficulty of keeping up a supply. There is no safety valve, no exhaust, no steam gauge, no boiler feed pump, no injector, nor any similar adjuncts of an ordinary steam engine. It is arranged to burn either hard or soft coal, wood, or coke, and petroleum or common gas may be used by conducting pipes into the fire box. The manufacturers claim that when hard or soft coal or coke is used, the cost will not exceed one cent per horse power per hour.

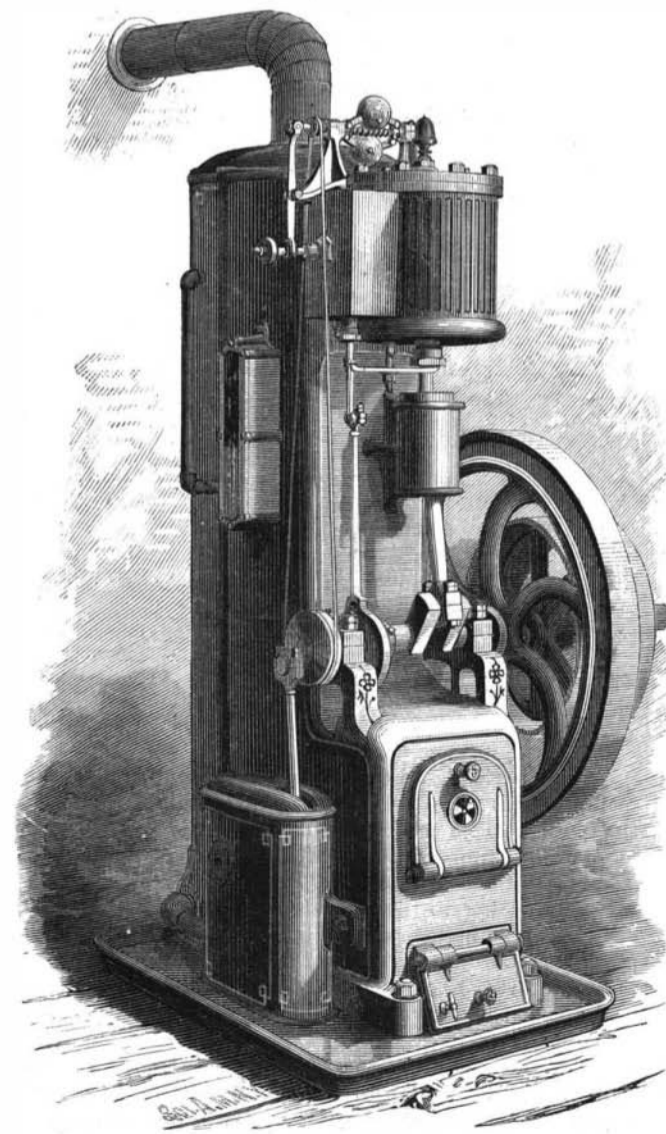

THE DAVEY SAFETY ENGINE.

BARON VON SCHOELER, of Corpus Christi, has for a pet an immense snake of the anaconda species. It is perfectly docile, so far as the Baron has yet learned.

Natural Gas in Pittsburg.

On January 31, a disastrous explosion of natural gas occurred at Pittsburg, Pa., by which four houses were badly damaged and twenty-two persons were more or less injured. The large main of the Fuel Gas Co., conducting the natural gas from the wells at Murrysville to the consumers in Pittsburg, passes close along the curb on Butler Street at Thirty-fourth. The pipe is wrought iron with screw joints. The high pressure of the gas and its great penetrative quality make it, seemingly, impossible to prevent leakage. The gas accumulating in cellars near the corner of Thirty-fourth and Butler Streets in large quantities was ignited and exploded. These explosions are of alarming frequency. The gas companies, with all known appliances for controlling the gas, cannot master it. The Fuel Gas Co. is trying a new plan. Their pipes will be surrounded with charcoal. In close proximity to the pipe, and within the zone of charcoal, a burnt clay sewer pipe is laid. This being porous, the gas escaping from the iron main finds its easiest escape into the sewer pipe; at frequent intervals escape pipes are carried from the sewer pipe to the tops of lampposts, where the leakage is burnt. It burns in a flame from three to four feet high. The Philadelphia Co. lays a double pipe; a small one, the high pressure, surrounded by a large one, a low pressure, which carries nothing but the leakage from the inner pipe. Dwellings are supplied from the outer pipe, mills and the like from the high pressure or inner pipe.

New Brazilian War Ship.

The Aquidaban, recently launched from Messrs. Samuda's shipbuilding yard at Poplar, is a twin-screw armor-clad turret ship, 280 ft. in length, 52 feet in breadth, and 18 ft. draught, with a displacement of 4,950 tons. The estimated speed is 14 knots, with 4,500 indicated horse power. The hull is built of Siemens steel, and is divided into a large number of water tight compartments, the principal of which are the four boiler rooms and the two engine rooms, which are each separate water tight tanks, so that if either of them were flooded the ship could, at a reduced speed, proceed on her course with the remaining set of engines and boilers. The bottom of the vessel to a height 2 ft. above the water line is sheathed with wood and metal to prevent fouling; the stem and stern post, upon which the wood sheathing ends, being made of massive gun metal castings.

TRACE OR HAME TUG BUCKLE.

In this buckle a clamping plate, or wedge and key, is employed for grasping and holding the trace, thus avoiding the necessity of making holes in the trace, as with ordinary buckles, and facilitating also the adjustment of the trace. Fig. 1 is a sectional elevation, Fig. 2 is a plan view, Fig. 3 is a side elevation of the cam or key, and Fig. 4 is an inverted plan view of the outer part of the frame. The main frame, A, is formed with a forward extension, c, for receiving the hame tug, side

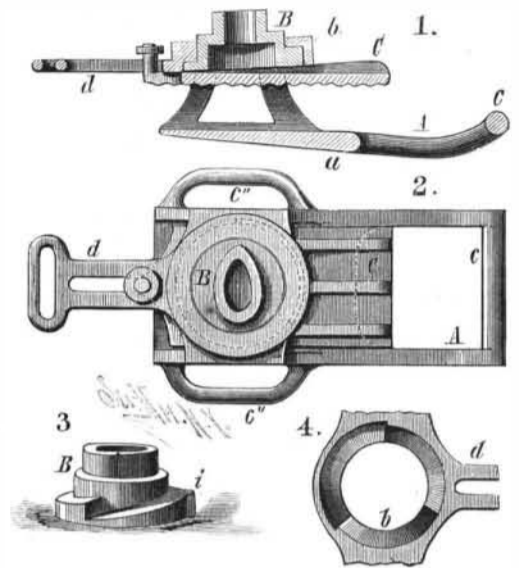

DEIBERT'S TRACE OR HAME TUG BUCKLE.

loops, c' c', for receiving the backstrap and belly band, and the rear extension, d, the loop of which receives the breech strap, and the slot receives the stud of the clamping plate, C. The space between the face plate, b, and the back plate, a, is wedge shape to cause the clamping plate, C, to more firmly grasp the trace. The clamping plate is attached to the buckle by the stud passing through the slot, d, and is free to move longitudinally, so as to grasp traces of different thicknesses; the inner surface is corrugated, as shown in Fig. 1; it is also formed with ribs which act against the key, B, the form of which is shown in Fig. 3. The key is moved by a wrench applied to the head, and its movement is limited to about one-third of a revolution. When the key is turned in one direction, it will be forced inward against the clamping plate to grasp the trace; and when turned in the opposite direction, the trace will be released. This is effected by the cam surfaces of the key moving on those on the under part of the face plate of the frame, indicated in Fig. 4. This buckle will securely hold the trace without injuring it, and the wedging action will increase according to the draught upon the trace.

This invention has been patented by Mr. A. E. Deibert, of 585 McGee Street, Kansas City, Mo.

Iridium.

Iridium is a metal which is likely to have a much more extensive employment than it now enjoys. Hitherto it has been chiefly used in alloy with osmium for tipping gold pens. But an American pen manufacturer has discovered that by fusing the metal at a white heat and adding phosphorus perfect fusion could be obtained, with all the hardness in the resulting material of the iridium itself. For mechanical applications this combination is exceedingly useful, as in the case of pen points; and its adaptability is being proved in many ways. Agate, which has hitherto been employed for fine chemical balances, is now giving place to iridium, which takes a finer edge and is not so liable to catch or break.

Hypodermic needles for surgical use are now made of gold and tipped with the iridium compound, which is not subject to corrosion like the old steel points, and it is also being largely applied to instruments for surveyors and engineers and to electrical apparatus. Iridium can be obtained somewhat abundantly from the Russian platinum mines in the Ural, and it is found in combination with gold in California. Mr. Dudley, of Cincinnati, is engaged on experiments with the object of plating vessels with iridium, and as the metal resists the action of acids, it is likely that such vessels will be very useful in many chemical operations.—*Chem. and Drug.*

ECONOMICAL STEAM TRAMWAY.—The half year's working account of the Dewsbury, Batley, and Birstal Tramway, the first ever constructed in England, and worked by Merryweather 7 inch engines, shows the total cost of the running of the engines to be 2'57d. per mile, and the total expenses of the whole establishment, including locomotive charges, 5'16d. per mile. This is one of the most economically worked lines in England.