

**Bleaching Tallow.**

The Oil, Paint and Drug Reporter recommends the following as the best process known to it for bleaching tallow.

About 50 lb. of caustic soda lye are placed into a clean boiler and the steam is turned on. Salt is then added to the lye until it shows 25-28 deg. B. The fat—300 lb.—is now placed in the boiler, and the steam is turned on until the mass is brought to a boil, when the steam is shut off to prevent overflowing. It is allowed to boil up 1-2 inches at the most, and then left to itself for 3-5 hours, so that the fat will clarify. At the end of this time, the upper saponified layer is ladled off; the pure tallow is removed and passed through a hair sieve or linen into a clean vessel, until the lower saponified layer is reached. The residue in the boiler, consisting of saponified fat and lye, is removed and used in the preparation of curd soap, together with the upper layer.

The kettle is thoroughly cleansed, and about 30-35 pounds of water with  $\frac{1}{4}$ -1 pound of alum are heated to boiling. To this solution the fat is added, and the mass is allowed to boil for about 15 minutes, until all the filth has disappeared from the fat. The mass is then transferred to another vessel, and left by itself for 3-5 hours.

The pure fat is then again placed into the boiler and heated to boiling, until it shows a temperature of 170-200 deg. C. In this last operation the fat becomes snow-white. The steam must be turned off as soon as the slightest trace of vapor of a disagreeable odor is thrown off. The fat may then be directly used or left to cool.

As has already been stated, the steam must be turned off or the fire removed as soon as a trace of disagreeable vapors becomes visible, whether the temperature be 150 deg. C. or 170 deg. C., for if this is not done the fat will again turn dark.

Freshly rendered, sweet fat (not acid or rancid) is most readily bleached, and may be heated quite high. Still the fat used should not be too fresh, or one will take the risk of saponifying the 300 lb. without leaving any to bleach.

Tallow which has been treated in this way, when used in toilet soaps, gives them a white color and agreeable odor. It is also well adapted for candle making, as it becomes exceedingly hard.

**Banana Peel as a Lubricator.**

A long yellow ice cart, heavily laden, slid the other day into a gutter in Chambers Street, near West Broadway. The rear wheel stuck firmly against the curb. The driver lashed his horses and swung them around, but to no purpose. Ingenious philanthropists offered all kinds of suggestions, patted the trembling, sweating horses, and some put their shoulders to the side of the truck, but without avail. The off rear wheel would not turn. A barefooted little colored boy had watched the proceedings with a child-like look of sympathy for the overstrained animals. He suddenly ran down Chambers Street and returned panting, carrying in his arms a lot of banana peels.

"Say, boss," he called to the driver, "I'll make yer wheel turn with these 'ere, if yer'll let me put 'em down."

"All right, sonny," said the driver.

The little darky sprang under the wheels, and carefully laid down the skins. He pressed some close to the curb, where the wheel was jammed. Then he sprang back and shouted, "Now, boss; pull away."

The crowd laughed; the driver pulled taut his lines and gave his horses a lash. The animals sprang forward, the wheel glided along the layer of banana peels, and the heavy wagon rolled out of the gutter. The onlookers cheered as it drove away.

"Oh," said the little darky, "I've seen pop move barrels and big boxes with oil, and pop tole me a little oil makes hebbly dings go round. I seen hebbly men fall on banana peel, and I guessed dey'd move dat wheel. My name, boss, am Abraham Lincoln George Brown."—*N. Y. Sun.*

**Consumption.**

Dr. Edgar Holden, Medical Director of Mutual Benefit Life Insurance Company, Newark, N. J., says: For many years, even among the best informed, the impression has prevailed that consumption exhibits a preference as regards development, for certain ages. Thus, it has been the conviction that those who escape the marasmus and tubercular meningitis of infancy come again into danger at puberty, and that again between thirty-two and thirty-eight a climacteric is reached at which the mortality acquires its maximum of intensity, then diminishing, to declare a wholesale sweep between sixty and sixty-five.

These views have grown out of an experience apparently well founded, since the mortality in every physician's personal field of observation has seemed to be greatest at those periods, but the conclusion is nevertheless a fallacy, and it has been made broader and deeper by statistics of mortality in which the ratio of deaths from consumption to the total number of deaths has been relied upon.

Rare facilities for prosecuting an investigation to obtain a correct result have led me with considerable labor to a conclusion as startling as I trust it will be found conclusive, namely, that death from consumption, instead of being, as is almost universally supposed, most prevalent in early adult life in this country, is in reality not so, but grows relatively more frequent as life advances. This is true in the community at large, and among selected lives is actually less at the ages hitherto deemed most susceptible.

**SCREW TAP.**

The stock, A, is formed with a head, B, provided in its rim with a series of longitudinal grooves, C, that receive the cutters, D, the outer ends of which are held flush with the end of the head. The grooves, C, are formed with side grooves, E, and the corresponding surfaces of the cutters are similarly grooved. The cutters are prevented from being lifted out of the grooves by locking wires which are passed into the aperture formed by the two small grooves. A disk, F, held on the end of the head by a screw, partly overlaps the outer ends of the cutters and prevents them sliding out of the grooves. Mounted on the screw threaded portion of the stock is a nut, H, formed with an annular ridge, I, on which the inner ends of the cutters rest. The cutting teeth at the front ends of the cutters wear off more rapidly than the rear parts, and if they become too dull to cut, the disk

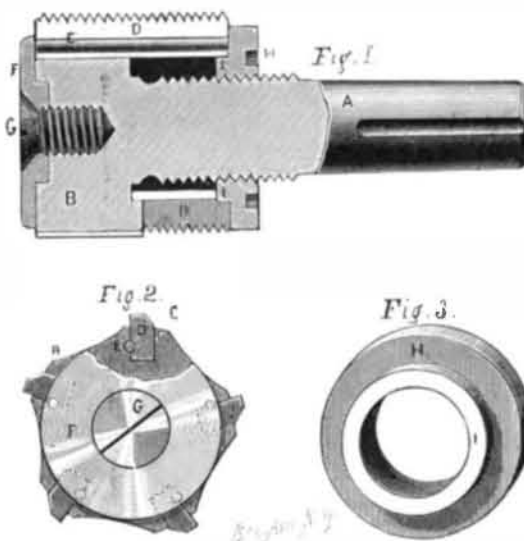
**EDDY'S SCREW TAP.**

is removed, and the cutters are moved forward to project from the head by turning the nut; the ends of the cutters are then ground off flush with the end of the head.

This invention has been patented by Mr. H. W. Eddy, whose address is corner Euclid and Waite Avenues, Toledo, Ohio.

**WELL BUCKET.**

An invention recently patented by Mr. R. H. Foat, of Weatherford, Texas, is illustrated in the accompanying engraving. The top ring of the bucket has a cross bar having a central aperture, through which the valve rod passes. The lower edge of the ring is formed with an annular rabbet for receiving the upper edge of the cylindrical casing, A, that is made of sheet iron. The lower edge of this casing rests in a rabbet made at the upper edge of a cup, C, forming the bottom of the bucket. In the bottom of the cup is an aperture, in the edge of which is formed a rabbet for receiving the edge of the valve, D, held by nuts on the lower end of the valve rod. At the top of the cup is an apertured bar through which the valve rod passes.

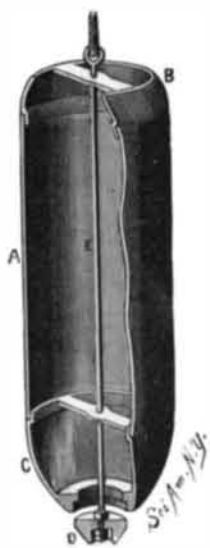
**FOAT'S WELL BUCKET.**

The upper ring, B, the cup, and the valve are made of malleable iron. The rope is attached to an eye formed at the upper end of the valve rod. By this means a simple, strong, and durable bucket is constructed.

**Destruction of Fish by Dynamite.**

Thousands of dead fish have been floating down Niagara River of late; among them have been large sturgeon, handsome muscalonge, black bass, and cat fish. On the beach, also, from Bay View to Dunkirk, the dead bodies of fish have been washed ashore. All appeared to have died within a short time. This wanton destruction is believed to have been caused by a party of reckless young men who sailed about in a steam yacht and now and then lowered into the water dynamite cartridges, which were exploded by electricity.

**Rattle Snake Bite.**

Perhaps there is no place on this continent where rattle snakes do congregate in greater numbers than along the Tioga River, in Pennsylvania. The mountains through which that crooked stream finds a passage are the home of the rattle snake, and in the warm summer months they leave their dens by thousands for the narrow valley, where they bask in the sun for a few weeks, and those that do not get their heads bruised by the heel of man, or get cut in pieces by lying nights on the warm rails of the Corning and Blossburg railroad, as thousands of them are, crawl back to their dens in the rocky ledges. In midsummer it is an almost daily occurrence for some one to be bitten by these reptiles in the Tioga Valley, and domestic animals are frequently bitten. But the residents of this region do not look upon the bite of these reptiles as anything serious. When a person is bitten, a handful of mud or wet clay is applied to the wound, and fresh applications are made every ten or fifteen minutes until the poison is all drawn out. The first thing a native of that locality does after being bitten is to seek a place where hogs wallow, where soft mud or wet clay is always found. He binds on a quantity, and is soon cured. The same is applied to domestic animals when they exhibit symptoms of snake bite, and this treatment is always successful if the application is made before the poison has gone too far. It is well known that hogs are not harmed by snake bites, and this is accounted for by the porkers' habit of cooling off by lying in a mud hole.

A farmer on the line of the Corning and Blossburg railroad had a small cur dog that made it his business to kill rattle snakes. In his encounters with large ones he would be bitten several times, but as soon as the fight was over he would hasten to the farm yard and lay himself in a "hog wallow" for several hours, when he would come out entirely free from poison.

It is well to fortify the system with stimulants, then apply the clay mud, and a cure is certain. The clay must be moist, or of the consistency of dough.

WM. S. HUNTINGTON.

We are inclined to think that the snakes referred to by our correspondent were of a different breed, or age, or condition from some of those whose bite is fatal. On the 13th inst., in this city, James Reilly, a snake charmer, who was exhibiting rattle snakes, and had taken one of them out of its box, according to custom, was bitten in the right hand by the reptile. The man returned the snake to the box, and began at once to suck the poison from the wound with his mouth, then swallowed a quart of whisky and went to the hospital. Here he was treated with hypodermic injections of whisky and sedatives; other remedies were also tried, but it was of no avail. After lingering for over twenty-four hours in agony, the unfortunate man died. Reilly himself declared his belief that the bite of that particular kind of rattle snake—diamond back—was always fatal.

A few hours before Reilly died a Westchester County farmer named Purdy appeared, bringing what he claimed to be a sure cure, as it had saved the lives of at least fifty persons. He was allowed to try the remedy upon the sick man. It consisted of a decoction of herbs. The only effect was to produce a short sleep.

**New Apparatus for the Relief of Deafness.**

Professor Politzer describes in the *Wiener Medizinische Wochenschrift* a little instrument invented by himself to aid those whose power of hearing is impaired. The principle is to transmit the vibrations from the pinna to the membrana tympani. Politzer opposes Voltolini's opinion that the cartilage of the ear is a poor conductor of sound, and on the contrary believes that the pinna, by means of its vibrations, is of great importance in the mechanism of hearing. His apparatus consists of a small elastic drainage tube, one end of which is beveled off so as to rest evenly against the drum membrane, while the other end is curved slightly, and by its elasticity presses gently against the anti-helix. Near its outer extremity the tube is attached to a small concavo-convex rubber plate. This plate is fitted so that its concave side lies in apposition with the concavity of the concha. The idea of this attachment is to increase the conducting power of the instrument and to transmit with greater facility the vibrations of the pinna. In a large number of experiments made to test the value of this instrument, the inventor found that in most cases the hearing distance for the voice was considerably increased, in some instances from two feet without to fifteen or twenty feet with the apparatus. In many cases the hearing distance for the watch was also increased, though in no such striking degree as that for the voice. In cases in which the drum membrane was partially or entirely destroyed, it was found necessary to attach an artificial drum to the inner extremity of the tube. In deafness due to ankylosis of the ossicles or to disease of the labyrinth, little or no improvement was obtained by the employment of the tube.

**Crushed Ice for Burns.**

The value of crushed ice as a dressing for burns and scalds, first pointed out by Sir James Earle, is confirmed by Dr. Richardson (*Aselepiad*, 164). The ice, after being reduced by crushing or scraping to a fine state of division as dry as possible, is mixed with fresh lard into a paste, which is placed in a thin cambric bag and laid upon the burn. This is said to banish all pain until the mixture has so far melted that a fresh dressing is necessary.