

AUTOMATIC GAME COUNTER.

The annexed engravings represent a game counter that is compact, convenient, and useful for nearly all games of cards, and is especially adapted to the modern game of whist. This counter, besides scoring the points made in each game, indicates and records the aggregate number of games and points made during a series of games. It can be readily set for games of five or seven points, and it will record up to nine games and ninety-nine points inclusive. By moving the arrow or pointer in a certain manner, either the games or points can be worked independently of each other.

This counter is supposed to beset for a game of five points. Before beginning the game the arrow should be placed at 0, and the apertures in the dial should also show ciphers. To do this the arrow is turned from 6 to 7 until the aperture

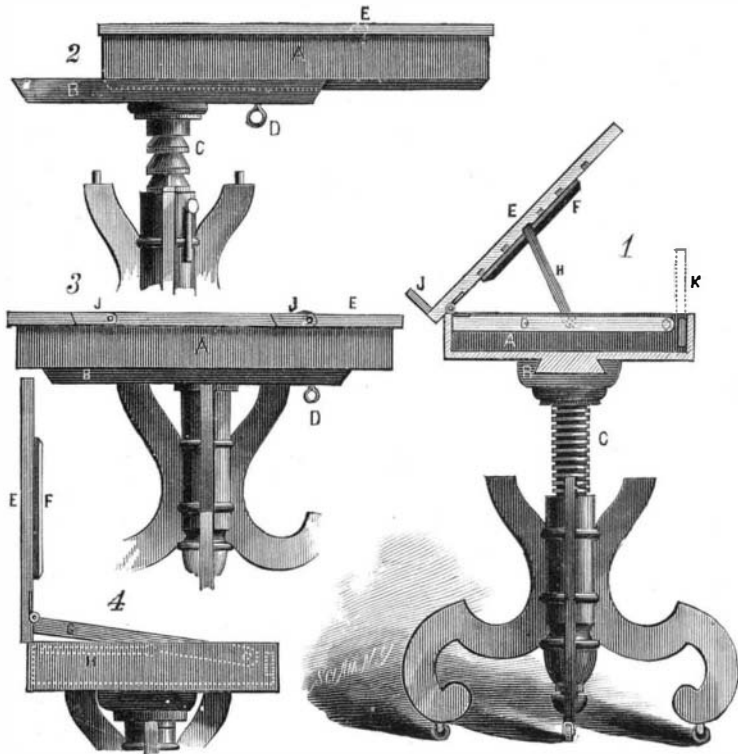

KOSSBIEL'S NOVEL TABLE.

“games” registers 0. By turning the arrow from 0 to 6, and forward and backward between those figures, ciphers will appear at the lower apertures marked “points.”

As the game progresses and points are made, the arrow is turned by the knob from left to right as the points are made up to 5. When this number is reached the figure 1 appears in the aperture marked “games,” and the figures 1 to 5 appear successively as the points have been made in the lower apertures marked “points.”

The arrow is then turned back to 0, and as the play progresses in the new game and points are made, the arrow is moved and the number of the accumulated points is registered in the lower apertures, showing the whole number of points made, whether a game has been won or lost. When the game has been won by the opponent, the arrow standing wherever it may happen to be (between 0 and 5) must be turned back to 0 before beginning the new game. If more points are made than enough to finish the game, the arrow must be turned to 5, thus scoring the game, then back to 0, and then

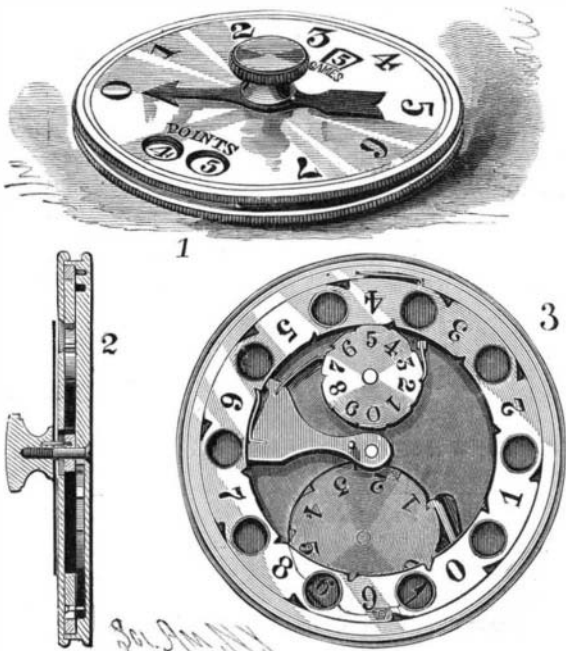

DAYTON'S AUTOMATIC GAME COUNTER.

forward to the number of points of surplus or laps made. If desired for clubs, etc., the counter can be made so as to register ninety-nine games and nine hundred and ninety-nine points.

The counter has been made in nickel plate, and has also been made and set in a watch case, and works in a similar manner as the one above described, the small or hour hand taking the place of the arrow, and noting the points on the

dial, the long or minute hand recording the total number of points made, and the second hand recording the games, all worked directly by the stem. The figures on the dial are in two colors, making it a very neat and attractive article. These goods are not on the market yet, but arrangements are being made to place them at a reasonable and moderate cost.

The invention has been patented by Mr. Frank Dayton, of Portland, Oregon; New York address, P. O. Box 1967

A NOVEL TABLE.

The under side of the table is formed with a central track plate which fits in a groove in a plate, B, held on the end of the spindle, C; the track plate is locked in place by the binding screw, D. The spindle passes into the top of a tubular standard supported by a suitable base of any desired shape, and can be screw threaded as shown in Fig. 1, or provided with a series of grooves forming beveled annular shoulders, in which case the standard is furnished with a spring catch (Fig. 2), the end of which projects through the standards so as to engage with the shoulders. When the spindle is formed with shoulders, the upper ends of the arms are provided with upwardly projecting pins that pass into holes in the bottom of the plate to hold the table steady and in place when lowered. The top plate, E, is hinged to the ends of two arms, G, pivoted at the opposite ends to the inner surfaces of the end pieces of the table; both longitudinal edges can thus be swung upward. The braces, H, fold into grooves in the upper edges of the end pieces of the table, and their upper ends enter apertures in the under side of the top plate. When the plate, E, and arms, G, are turned upward together on the points of the arms, they are supported in an inclined position—the reverse of that shown in Fig. 1—by the braces. A mirror, F, is secured to the under side of the top plate, to which are attached the clips, J, that fit in recesses and can be turned upward to prevent the book or paper from sliding off. The table can be adjusted vertically by means of the spindle. When it is to be used as a sick bed, it can be extended laterally by drawing the top in the direction in which it is to project, and locking it in place with the binding screw. It can thus be adjusted to project partly over a bed or sofa, so as to be very convenient for the person using it. By resting the top plate on the arm, K, it may be used as a writing desk. It may be adjusted as a toilet table by swinging the top into a vertical position.

Further particulars may be obtained by addressing the inventor, Mr. Charles Kossbiel, of Cuero, Texas.

Gas from Pinewood.

M. Combe d'Alma, member of the Agricultural Society of La Giroude, has succeeded in producing illuminating gas by the distillation of the sea pine (*Pinus maritima*). M. D'Alma was engaged at St. Nerac (Lot-et-Garonne) in the production of a special kind of macadam; and part of the process consisted in baking clay. This was effected by the aid of the pinewood found in the district, which formed excellent fuel. It occurred to M. D'Alma, however, that it would be more advantageous to employ not the wood itself, but the gas which might be produced by its distillation. He therefore at once obtained permission to conduct a number of experiments at the gasworks in the town, and eventually succeeded in producing a gas with which he supplied the public and a considerable proportion of the private lights for two nights in succession.

On the first night the effect was not altogether satisfactory, owing to the material used being sodden and of bad quality; but on the second occasion the lighting was entirely successful. The event caused some excitement among the municipal authorities, who appointed a commission to vouch for the success of the experiment. This they did, and have since expressed a desire that the matter may be taken up by the municipalities of those places in the southwest of France where this particular species of pinewood is to be found, with the view to its profitable utilization for gas making purposes. M. D'Alma has satisfactorily proved that the distillation of pinewood in closed vessels is thoroughly practicable; and he believes that the resulting gas could be produced at a much lower cost than that of ordinary coal gas, while the sale of the residual products (charcoal, tar, and an acid liquid) would defray the whole expenses of manufacture.

Close of Another Year.

One more number, and volume fifty-one of the SCIENTIFIC AMERICAN will close, and with it several thousand subscriptions will expire. To save the removal of such a large number from our subscription lists, and insure a continuance of the paper without interruption, subscribers will be benefited and our subscription clerks greatly relieved by the remittance of subscriptions before the year closes.

AUTOMATIC ALARM FOR BEARINGS.

The engraving shows a device for giving an alarm or signal when the bearings of shafting or parts of machinery become overheated by friction. A fusible head is attached to the end of a wire connected with a lever fulcrumed on a post fastened to the box. The outer end of the lever is bent downward to form an arm to which a bell is connected, and the end of the arm carries a foot piece which is struck by a stud on the shaft when the bearing becomes hot enough to melt the fusible head. This head is held in contact with the bearing by confinement beneath a bridge piece, through which the wire passes loosely. It is evident that when the head melts, the weight of the bell will carry the arm of the lever down to the shaft, when the stud, striking the arm, will ring the bell at every revolution.

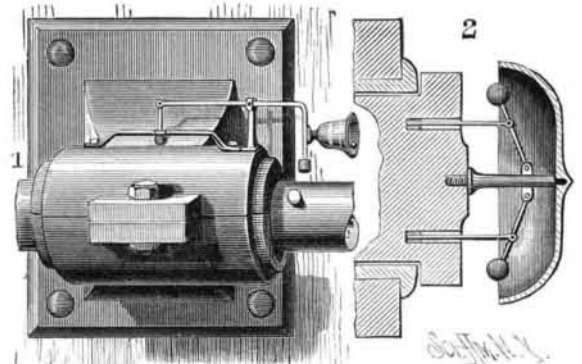

O'CONNELL'S AUTOMATIC ALARM FOR BEARINGS.

Fig. 2 shows the device applied to the crank pin bearing of an engine. The outer end of an arm carries a gong bell. The clappers are loosely connected with the arm and, by wires, with fusible plugs fitted snugly into end bores in the wrist pin. The clappers are thus held out of contact with the gong until the overheating of the bearing melts the plugs, when they are thrown outward by centrifugal force to sound the gong. This device may also be applied to give an alarm by the overheating of reciprocating or sliding surfaces.

This invention has been patented by Mr. John O'Connell, of 309 Broadway, Providence, R. I.

CASING FOR PIPES.

The engraving shows a casing for holding non-conducting material—such as mineral wool, etc.—on pipes, and which can be easily applied and fitted, and closed and locked without requiring the use of solder. A disk formed with a central opening to receive the pipe is of such size as to fit within the casing. It is cut open to permit placing it on any desired part of the pipe, and has its outer edge bent down to form a flange. A series of apertures is punched in the disk to allow the non-conducting material in the different compartments to unite by the fibers passing through. A sheet of metal from which a tube section is made has one edge creased to form a longitudinal pocket for receiving the other edge of the plate; the pocket is formed a short distance from the edge, so that when the free edge is in the pocket the edges will overlap. The joint is shown very clearly in Fig. 2. The edges of the casing sections are overlapped, and then held together by pins or nails passed through holes. The sections can thus be opened very easily to pass them around the pipe and to put in the filling material. One end edge of each section is creased to form an annular pocket to receive the adjoining edge of the next section, as shown in Fig. 1. When a pipe is to be covered, a series of disks is placed around it, a casing section is put on and secured with the

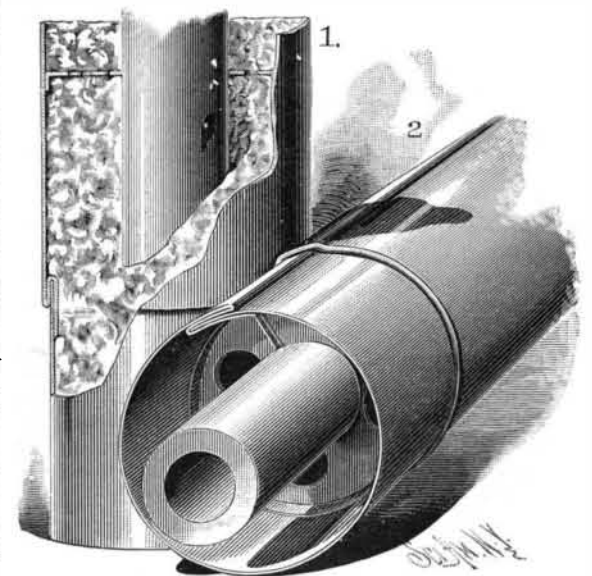

WOOD'S CASING FOR PIPES.

pins or nails. When filled with the non-conducting material, another section is placed adjoining it.

This invention has been patented by Messrs. James F. and John F. Wood, of Wilmington, Del.

ENGLISH crown soap is an imported soft soap used by harness makers and the like for rubbing and polishing leather.

Removing Paint from Iron.

Mr. A. J. Bishop, of Cleveland, O., says: The greatest difficulty I have found in using potash has been to have it remain where put, and not run off of the work. By making various experiments, I have found that good lime used in proper proportions with the potash will not only make it remain where put, but is also a benefit to the strength and quickening of the potash, the lime acting upon the grease more readily: when too great an amount of lime is used, it has a tendency to harden upon the work, and then is as difficult to remove as the paint when first starting. One can also, I find, use too great an amount of potash; in like manner, if the liquid is too strong and lime is used, it has a tendency to crystallize and become hard. There are some objections to using potash, as it may injure the hands or clothes of the user, but to avoid this I have made use of hemp packing fastened to a stick, say two and a half or three feet in length; this gives the workman plenty of distance from his work, and he does not injure himself or his clothes, and also gives him a good swab or brush with which to apply the potash.

Another objection is the surplus of potash which may be left to remain upon the work, which, if not thoroughly removed, is injurious to the durability of the paint when repainted; but this can be avoided by extreme care being taken to remove the potash. In making tests to obtain proportions and results of different strengths of potash and lime, I obtained the following: My first was composed of 5 pounds lime, 6 pounds potash, and 7 quarts water; my second, 5 pounds lime, 4 pounds potash, and 7 quarts water; and I found that the latter was two hours the quickest in removing the paint from drivers of the same engine. Another trial was made with 14 pounds lime, 12 pounds potash, and 21 quarts of water for four pairs of drivers, and with this I found that it required equally as much time to remove the surplus of lime left upon the drivers as it took in the first place to remove the paint. Other tests, being made of 1 pound lime, 4 pounds potash, and 6 quarts of water, I found to work much better than any previously tried, and am satisfied that this proportion is about right. These tests were made with crushed potash. The average time required to remove paint from two pairs of drivers has been two men, seven hours, while the time for scraping for same men would reach three and four days for same work. The paint has been removed from a tank by two men in seven hours, and other parts of a locomotive in a proportionate length of time, while with heat for burning same, or scraping cold, the time is beyond mention for comparison.

Ordnance for Harbor Defense.

The report of the Armament Board appointed in pursuance of an act of Congress to make certain tests of artillery has been made to the Secretary of War. The Board interpreted the act of Congress under which it was appointed to refer only to mortars and guns of high power for the defense of harbors, and did not take into consideration the lighter guns required for the flank defense of permanent works. The Board first directed its attention to the depth of water in the channels leading to all of these ports, and then ascertained the number and thickness of armor of the known ironclads of the world which would enter these harbors. The powers of the guns necessary to penetrate these armors were then calculated, and the number of guns considered essential for a proper defense of the harbors was decided upon. In that determination the Board was guided by a list of guns and mortars which had been prepared by the Board of Engineers for Fortifications after careful study of the subject.

The Board submits tables which embody its views, and which, summarily stated, call for 125 eight inch guns 21.5 feet long, to weigh 13 tons each and to carry projectiles weighing 285 pounds; 226 ten inch guns 26.875 feet long, to weigh 25 tons, and to carry projectiles of 575 pounds; 306 twelve inch guns 35.11 feet long, to weigh 48 tons, and to carry 894 pound projectiles; 50 sixteen inch guns 45.93 feet long, to weigh 107.77 tons, to carry projectile of 1,631.4 pounds each; 512 twelve inch mortars 10.33 feet long, to weigh 13.06 tons; and to carry 610 pound projectiles. These guns will have a penetrating force at 5,000 yards through thicknesses of wrought iron as follows: 8 inch caliber, 10.39 inches; 10 inch caliber, 15.16 inches; 12 inch caliber, 17.25 inches; 16 inches caliber, 23.20 inches.

In conclusion the Board states that it deems it of the utmost importance that the guns and mortars above specified should be procured at the earliest date practicable.

A Formula for Nervous Headache.

From the *Maryland Medical Journal* we note that Dr. A. L. Hodgdon, of Farmwell, Va., recommends the following recipe for nervous headache:

- R. Alcohol dilut. ʒ iv.
- Olel cinnamom ℥ iv.
- Potas. bromid ʒ v.
- Extr. hyocyam. fl. ʒ ias.
- Fiat lotio.

S.—One to two teaspoonfuls, if required.

Dr. Hodgdon has used this combination with universal success. It is not disagreeable to take, and has no bad effects.

DOUBLE STEAM HAMMER.

Messrs. B. and S. Massey, of Manchester, have recently constructed for Messrs. Tangye, Birmingham, a specially

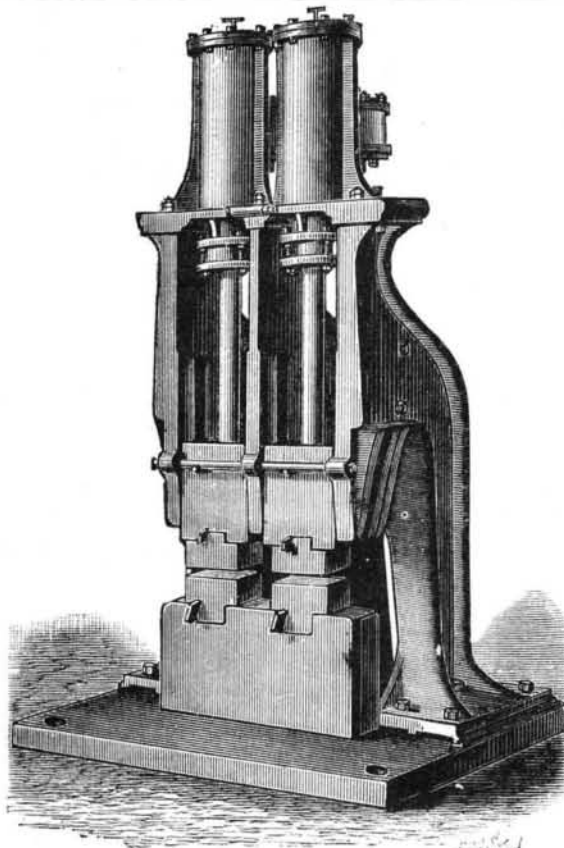

DOUBLE STEAM HAMMER.

designed double steam hammer. There are, as shown, two hammers of the same size, which can be worked either together or independently. By this arrangement one hammer may be delivering sharp and rapid blows while the other is striking slowly and heavily, or one may be stopped entirely while the other is at work. This arrangement of double hammers is intended principally for work which requires to be passed quickly from one to another at the same heat, and as the two tups or hammer heads are not more than about 4 inches apart, this can be done with greatest facility. As compared with two separate hammers there is also a reduc-

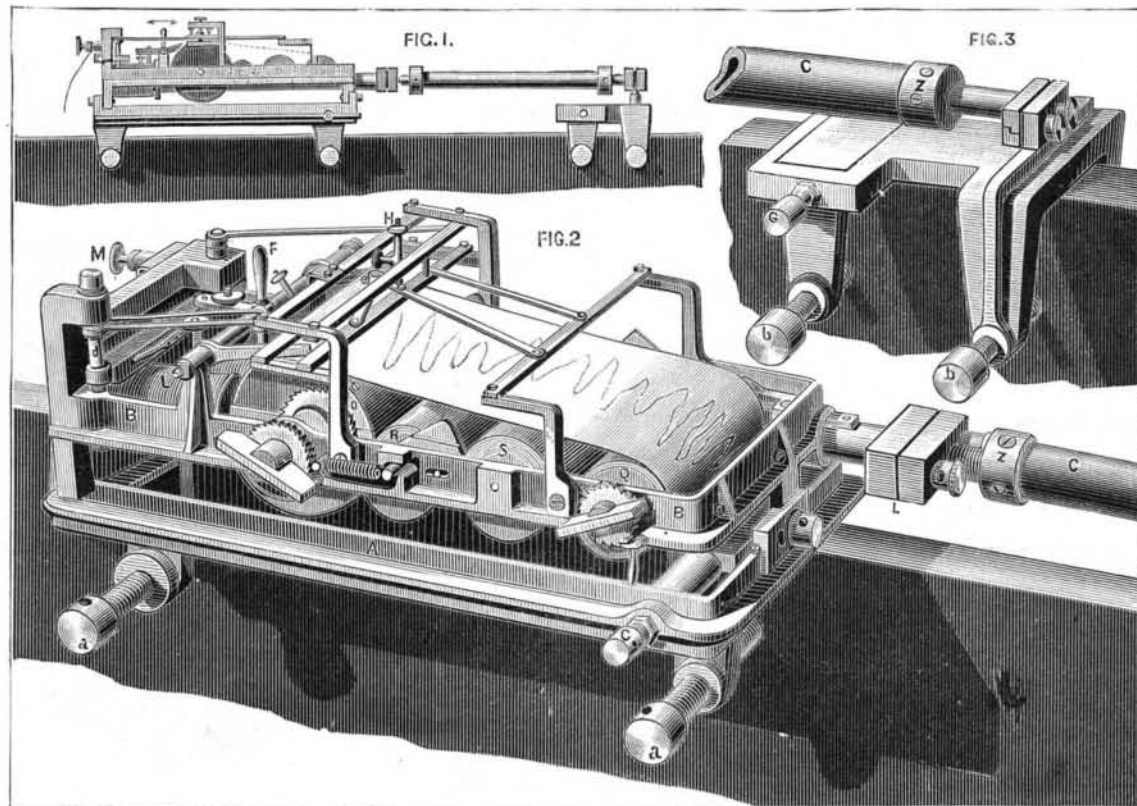

FRANKEL'S REGISTERING DYNAMOMETER.

tion in expense, as one base plate, one anvil block, and the central member of the framing are common to both hammers. For the same reason there is also a saving in the foundation and in the floor space required. The falling weight of each hammer, independent of top steam, is 7 cwt. It may be added that the arrangement is applicable to three or more hammers should they be required, and is not confined simply to a pair of hammers, as shown in our illustration

FRANKEL'S REGISTERING DYNAMOMETER.

The apparatus shown in the accompanying engraving is designed for ascertaining the stresses that occur in metallic bars under variable loads, and not only for observing them, but also for writing their true history from instant to instant. It makes the bar itself write this, and allows the observer to ascertain when the experiment is ended and what has taken place, and to draw all the deductions therefrom that he pleases.

Every one knows that when we pull on a wire or rod it elongates. If the bar be compressed, it shortens. The whole science of the calculation of resistances is founded upon the simple fact that, in the same rod, the elongations or contractions are proportional to the stresses undergone. And, again, such variations in length are proportional to the stresses per unit of section per square millimeter (1 millimeter = 0.0394 inch), for example, in rods of any dimensions whatever. This is what is taught by the theory of elasticity.

It is this very simple property that Dr. Frankel has utilized in the invention of his registering dynamometer.

He takes a certain length of the wire that is to be examined, fixes clamps to its extremities, and makes it inscribe upon an unwinding sheet of paper the variations that it is undergoing in length. For example, knowing that with iron a length of one meter (39.4 inches) increases 0.05 millimeter when the tension that is exerted is one kilogramme (2.204 pounds) per square millimeter, it will be easy, by measuring the elongation inscribed upon the paper, to find how much the section of the bar experimented with has been stretched or compressed per square millimeter.

The principal part of the apparatus consists of a cast iron frame, A (Figs. 1 and 2), which is firmly fixed to the rod experimented with by means of a binding screw, and which carries the registering mechanism. Along one of its sides, and parallel with the bar, there is a round movable rod, whose head, L, projects from the frame and receives a small sphere that belongs to another hollow rod, C, about 0.8 meter (31.5 inches) in length. The other extremity of this latter carries an analogous sphere, which is set into a head like the first (Fig. 3), that is carried by an independent jaw fixed to the bar. The screw, b, of this jaw, and the corresponding screw, a, of the frame, A, determine the length of the bar on which the experiment is made. The head, L, being fixed to the jaw, the rod, C, will be carried along if the bar elongates or shortens, and, while at the same time keeping at a constant length itself, its other extremity will move with respect to the principal frame, A.

Let us imagine, then, that such extremity has a plane surface, and that against it there presses, under the influence of a spring, a small sphere carried by a lever jointed to a fixed axis. This part is unfortunately hidden by the apparatus (Fig. 2). Every motion of the rod, C, will cause the lever to move, and if the proportions of its two arms are properly chosen, its other extremity will amplify the motions of the little sphere that is in contact with the rod. A new transmission of motion, effected by means of a pinion and a toothed sector, will permit of a further amplification of the motions observed, and, without our entering into details, it will be seen that we shall finally obtain, through the inscribing pencil, H, motions that will be an exact multiple of the deflections of the head of the rod, C. In the apparatus, as constructed, this multiplication is always about 170 times the variation of the length to be measured. In starting from the figure indicated above, it will be readily seen that if a millimeter per meter of real elongation of the rod corresponded to a stress of 20 kilogrammes per square millimeter, one millimeter of the diagram obtained would correspond to $\frac{20}{170} = 0.117$ k. (4.14 ounces) per millimeter (0.0394 inch).

The inscription is made upon a paper which unwinds slowly under the pencil. The cylinder, Q, contains a tension spring which does the unwinding, and the motion of the paper is regulated by a clockwork movement in the drum, D. The other, and intermediate, drums are designed for regulating the tension of the paper and keeping it close to the surface upon which the pencil bears. The rectilinear motion of the latter is obtained by an upper parallelogram, and, in order to have a sure datum point, a second pencil, near a leverhandle, F, traces a continuous line to which are easily referred the ordinates of the curve obtained.

As the paper unwinds with a certain velocity, it is important that it be not wasted when no experiment is being tried. For this reason the starting may be effected by hand or electrically by means of the lever, F, and it may be rendered automatic, especially, for example, when a train is about to cross a bridge whose working it is desired to ex-