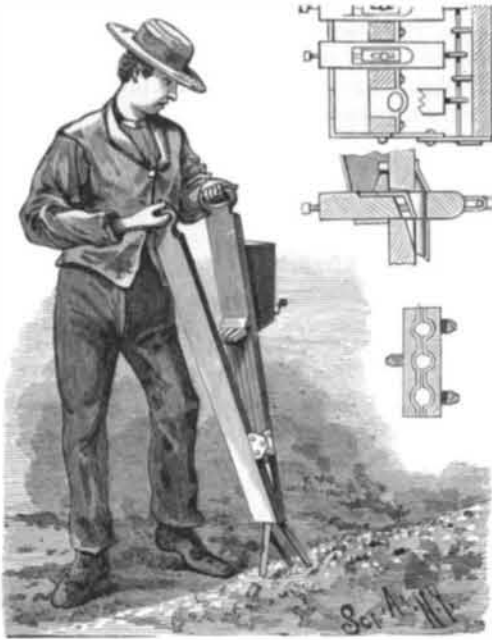

**HAND CORN PLANTER.**

The corn planter recently patented by Mr. J. T. Ricketts, of Camargo, Kentucky, deposits the kernels in the ground separate and in a triangular space, so as to make the hills compact and leave as much room as possible between them. To the side edges of the bars of the planter, at a little distance from their lower ends, are attached plates, the adjacent edges of each pair of which are overlapped and hinged to each other by bolts. To the outer side of one bar is secured the seed hopper, from which the seed is removed by the slides which pass through openings in the bar and in the side of the hopper. The inner ends of the slides are

**RICKETTS' HAND CORN PLANTER.**

connected with the other bar, so that they will be operated by the opening and closing of the bars. (This construction is shown plainly in the upper view, which is a sectional plan through the slides; the center cut is a vertical section through the slides and hopper. The lower cut is a sectional plan through the lower part of the bars.)

In each slide is formed an opening, to receive the seed and carry it out of the hopper, and the size of which is regulated by plates inserted in the opening and adjusted by hand screws. Brushes attached to the bar above the openings through which the slides work prevent the slides from carrying out any more seed than the openings will hold. The seeds pass through passages formed by covering grooves in the inner side of the bar with semi-cylindrical plates, which extend down to the hinges, where they meet similar plates having their concave sides toward each other. At the lower ends of the bars two pairs of plates are bent forward, and the third pair is bent rearward, so that the lower ends are equidistant from each other.

To use the planter the bars are drawn apart, thereby closing the lower plates and drawing back the slides, and allowing the seeds to drop into the passages. The tubes are then thrust into the soil where the hill is to be planted, when the bars are drawn toward each other, which separates the lower plates and permits the seeds to drop.

**STEAM TRAP.**

The valve case is made of two circular cup-shaped plates, bolted together and containing a circular seat having ports

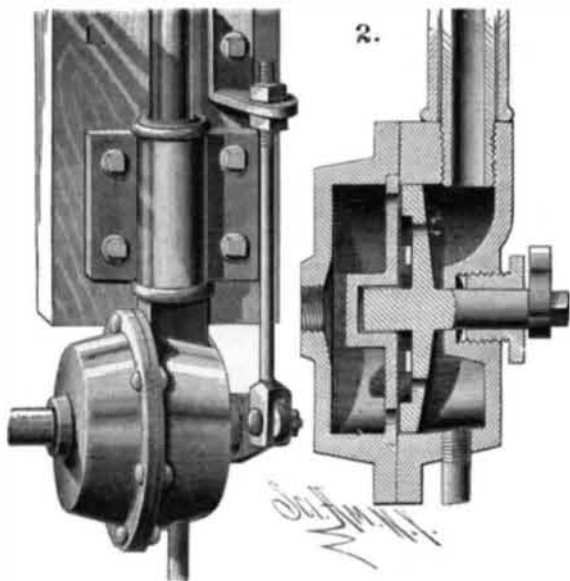
**MORSE'S STEAM TRAP.**

for the escape of the water condensing in the upright pipe and the first chamber, into the second chamber, from which it flows away through the outlet pipe. In the first chamber, fitted on the circular seat, is a disk valve having ports through it and chambers in the face for the escape of water when these chambers are opened to the ports in the seat, which is effected by the turning of the valve. The valve has a stem that is centered in a socket of the seat and also in a stuffing box, through which it extends to the outside of the case, where

it connects with a crank arm, from which a rod extends along the pipe a short distance, and connects with a bracket attached to a wall plate, so as to be held rigidly to shift the valve when the pipe, to which the valve case is attached, expands and contracts, so as to cause the valve to open the ports to allow the water to escape and to close them to prevent the escape of steam after the water has been discharged. As the water flows out, the descending steam heats the pipe, which expands and closes the valve; when the valve closes, the steam condenses, and contracts the pipe so as to open the valve. The valve rod is connected to the bracket by nuts, so that it can be adjusted as required. The first chamber is provided with a waste pipe for blowing out the sediment that collects in the chamber. By this means a simple, efficient, and reliable trap for steam heating apparatus and the like is formed.

This invention has been patented by Mr. Robert B. Morse, of Naugatuck, Conn. The trap is in operation at the Good-year India Rubber Glove Company's Works at the same place.

**Hope as a Remedy against Disease.**

Dr. J. Mortimer Granville has been lately rather severely handled by the medical press of London, because he wrote a letter on this subject to one of the daily papers. He is criticised as having performed an unethical act in thus advertising himself in an unprofessional manner in a lay journal. This question we will leave to our transatlantic brethren, while we say a few words upon the subject matter of his letter.

But little touched upon, hope as a remedy against disease is, if wisely and judiciously employed, one of the most valuable and useful means that the physician can employ. Call it what we may, and reason about it as we please, no man of experience will for an instant question that imagination, the prejudices, the mental condition, the conviction of the patient, in many cases, exerts a most powerful and a most real influence upon the progress and termination of diseased conditions. Has it not happened to every one of our readers (it repeatedly has to us) to discover accidentally, so to speak, a condition of chronic disease, which has evidently been present for years, and yet the patient has maintained fairly good health, and is, at the time of the discovery, in no immediate apparent danger; yet when told that he is afflicted with an incurable disease that may carry him off in a few days, or that he may live for months, immediately wilts, like the sensitive plants when touched, and dies in a day or two?

Again, do we not all know of cases of chronic disease, in persons with a happy, hopeful, contented disposition, disease that we felt sure would soon prove fatal? And yet we see them go on day after day and year after year enjoying apparently good health. Of course we are familiar with and thoroughly recognize the fact that worry, that mental anxiety, is diametrically opposed to good health and long life; and in this fact we recognize the explanation of the influence of depressing opinions and advice; for if we tell a man with a nervous temperament that he *may* die in a few days, from that moment all peace and contentment vanishes from his life, while anxiety, worry, and unrest take possession of his whole being.

The practical point to be deduced from these reflections is that it will redound not only to your patient's advantage, but also to your own professional reputation, to make it a rule always to take the most hopeful view that is possible of the patient's condition, especially when the man or woman is one the "nervous, worrying kind," and always to remember that "hope kept alive" is the great secret of success among quacks. Let us steal their thunder.—*The Med. and Surg. Reporter.*

**RAIN WATER TRAP.**

At the top of the cistern is arranged a small receiving tank which is divided into two chambers, by a partition, one of which has a spout discharging into the cistern and the other has a pipe discharging into the bucket below. Over the tank is a section of the leader pipe, which is hung on a pivot and connected to a shifting cord by which it will be moved from side to side over the tank, according as the water is to be discharged into one or the other of the chambers. From the pipe the cord extends in opposite directions, connecting on one side with a weighted lever, and on the other side with a lever from which is suspended a float in a tank standing under a spout discharging from the bucket. As the water enters this tank it raises the float, when the weighted lever pulls the pipe so that it will discharge into the chamber leading to the cistern, the roof having been washed clean by the water which escaped through the tank. The center bucket is provided with a waste passage through which most of the water passes away, while some discharges into the lower tank to raise the float, so as not to allow the spout to be shifted too soon. In order to prevent the spout from shifting when the rainfall is not sufficiently heavy to wash the dirt from the roof, but is so continuous that it would raise the float and shift the spout, a notch, placed lower than the outlet pipe, is made at the lower side of the waste passage in the bucket, so that all the water will escape and none will flow into the float tank when the volume of water is too small to thoroughly wash the roof. After the rain is over the water is allowed to flow off from the lower tank, when the float descends and the spout is pulled back over the waste chamber ready for the next rainfall.

This invention has been patented by Mr. E. T. Toomer, of Mobile, Alabama.

**WELL BUCKET WINDLASS.**

The supporting frame consists of a pulley cap and spider frames which are cast together, and in the hubs of the spider are formed bearings for the shaft. Upon the upper quarters of the cap are formed bosses in which holes are tapped for connecting the suspension rods by screwing them in. These rods are attached to a board set up edgewise over the well, and supported upon posts placed at opposite sides of the well. The cap is provided with flaring ends to allow of swinging the buckets out over the well curb for emptying them. Keyed upon the shaft is a groove pulley that carries the bucket rope. One end of the shaft is squared to receive the crank. The shank is formed with a key, collar, and groove for ring to prevent its working out, and a squared portion, by casting or in any other suitable way. The groove in the pulley is made plain when a rope is to be used, but is cast with ribs when a chain is to be used. This con-

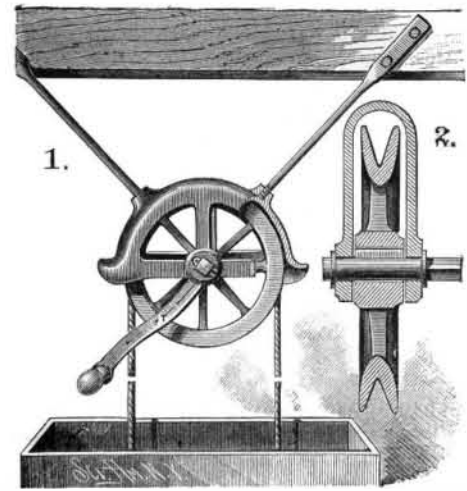
**PALMER'S WELL BUCKET WINDLASS.**

struction makes a simple, cheap, and easy working windlass for well buckets.

This invention has been patented by Mr. W. W. Palmer, of Nixon, Tenn.

**Curious Experiments.**

Among the results of Dr. Guthrie's experiments concerning solutions of salts is, that as a mixture in solution cools, the salt which is present in richest quantity crystallizes out until a certain critical point is reached.

Dr. Guthrie has shown that certain alloys of metal, such as the more fusible or "eutectic" alloys, which melt at low temperatures, behave in the same way as mixtures of salts. Moreover, there seems to be no definite molecular proportion obtaining in these alloys. A mixture of 47.38 parts of bismuth, 19.97 of tin, 19.36 of lead, and 13.29 of cadmium fuses at 71 degrees Cent., or a little less than 160 degrees F., or in boiling alcohol. This is still a lower temperature than the fusing of Rose's fusible metal.

Dr. Guthrie has also shown that definite mixtures of water

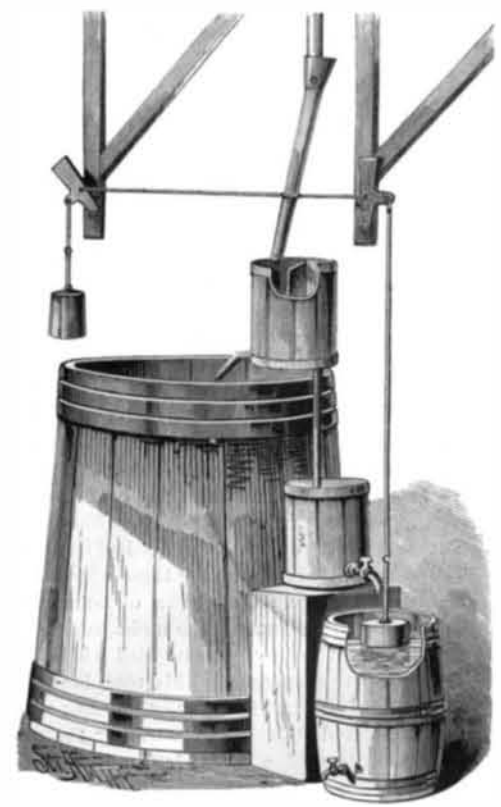
**TOOMER'S RAIN WATER TRAP.**

and triethylamine become turbid at or between certain temperatures, and on this basis he has constructed a set of temperature tubes containing the mixtures in question. When placed under the tongue of a patient, the temperature of the body at that point can be ascertained by their means. Dr. Tilden, of Edgbaston, has also shown that mixtures of water and butylic or amylc alcohols become turbid when between 20 degrees and 30 degrees Cent., and clear again between 140 degrees and 158 degrees F.

**The Effect of Incrustation in Steam Boilers.**

From our foreign exchanges we learn that the Boiler Inspection Association of Munich has been carrying out a series of experiments as to the actual loss resulting from incrustations in boilers. Tests were made with purified water and a perfectly clean heating surface, as compared with the results obtained with ordinary feed water, which had, however, been saturated with gypsum in order to abbreviate the duration of the trials. The principal experiment lasted day and night without intermission during a period of 195 hours. Eight observations were taken, in order to find what change had occurred in the results by reason of the augmented thickness of the incrustation. It will surprise our engineers to learn that although the latter had attained a thickness one-fifth inch to one-third inch, no decrease in the working power could be noticed. Unfortunately, the principal trial had to be interrupted sooner than was intended, as there were indications of the firebox being affected by the heat. The *Eisenzeitung*, in recording these trials, urges the advisability of their being carried out upon a more extensive scale with various descriptions of feed water, different kinds of incrustations being thus produced.

Trials made at Mulhouse would seem to have resulted in a diminution of effect only taking place at the commencement of the experiments, and to a small extent, there being no variation in the later period of the trials. The fact that there is a diminished production of steam, when a boiler has been left a certain length of time without cleaning, is attributed by the journal in question to the heating surface being covered with soot and to the presence of ashes in the flue. The purification of feed water is, however, still recommended on account of the avoidance by this means of the injury and danger arising from the deposit of incrustations or slime upon the fire plate. These experiments confirm Peclet's conclusion that the relative conductivities of heating surfaces in boilers have little or no effect on their efficiency, which is a different thing from their economy. A copper boiler will not make more steam in a given time than an iron boiler of the same dimensions.

**FEEDER FOR MILLS, PURIFIERS, ETC.**

Our engraving shows an invention in which the hopper, or other similar feeding device, is provided with a feeding roller applicable to mills, purifiers, and other machines which require an even feed spread over the entire length of the feed roller. The quantity of material fed can be varied without interfering with its uniform distribution over the entire length of the roller. A stationary piece, B, is secured to the front of the hopper by bolts and thumb nuts. Along the front of the bottom of the hopper is arranged the feed roller, C, which may be either smooth or corrugated, and is driven by suitable means. On the front, over the opening, is hinged the swinging valve, D, extending below the center of the roller. Secured to the hopper at the sides of the valve are two strips, E, that prevent lateral scattering of the material being fed. Placed parallel with these strips are springs, F, secured above and having their free ends resting on a flange on the lower edge of the valve, which is thereby closed against the roller. The tension of the springs is regulated by thumb screws, for the purpose of controlling the quantity of material fed over the roller and to suit different substances being operated on without interfering with the uniform spread of the substance over the roller. The upper ends of the springs are thickened and are made with grooves, K (Fig. 2), which fit over a rib, G, on the upper part of the strip, B, for the purpose of holding the springs to their places and to admit of their easy removal, when required.

The apparatus is also applicable to the feeding of substances of different specific gravities, from wheat to the lightest stock made in a mill.

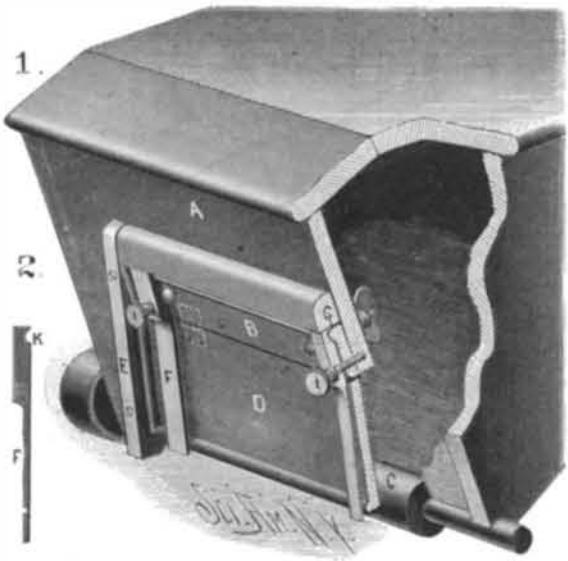

**FEEDER FOR MILLS, PURIFIERS, ETC.**

This invention has been patented by Messrs. W. S. Bonnard and W. H. Grupe, and additional particulars may be obtained by addressing the former, in care of Seiberling Milling Company, Akron, O.

A PONDEROUS ledger has just been turned out of the Government bindery for the use of the United States Sub-Treasurer at New York, which weighs 87 pounds, is 8 inches thick, and measures 21 by 32 inches.

**SHELL EXTRACTOR FOR FIRE ARMS.**

Fig. 1 is a perspective view of the gun, between the barrels of which the shell extractor (Fig. 3) is placed in any approved manner; Fig. 2 is a sectional elevation between the barrels. The extractor is composed of a stem, a head portion, and a brace which braces the head from the stem. The brace is made of steel in the form of a fin, formed or secured in the angle made by the stem and head, so that while it braces the head, it at the same time stiffens the stem, thus making the extractor strong and rigid in all directions, so that it is as durable as the other working parts of the gun. To avoid the unnecessary cutting of the barrel, the fin is beveled off at its inner end.

The utility of this device, which can be applied to any gun

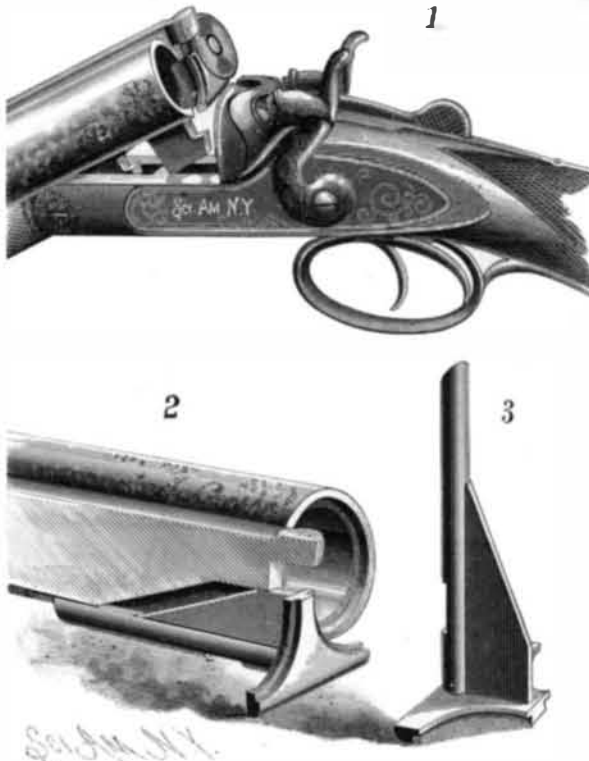

**WAYMIRE'S SHELL EXTRACTOR FOR FIREARMS.**

by a gunsmith or machinist, is apparent. The cost is trifling compared with the advantages it possesses.

Full particulars regarding both the United States and English patents may be obtained by addressing the inventor, Mr. N. O. Waymire, of Garfield, Kansas.

**The Oxygen in Water.**

At the Royal Institution a lecture on the above named subject by Dr. W. Odling, F.R.S., was recently given.

The lecturer began by stating that in 1823 Faraday proved that a gas or vapor is nothing but a liquid at a temperature above its boiling point; and he exhibited a number of glass tubes containing liquefied gases, which had been prepared by Faraday, who liquefied nearly every known gas. It is only within the last six years, he said, that the five or six gases which had previously resisted liquefaction have been reduced to that state by perfected modern appliances for producing cold and pressure. When gases are dissolved in water they somehow assume the liquid state therein, and increase the bulk of the water. At 0° C. 100 volumes of water dissolve 4.11 volumes of oxygen gas; at 15° C. they dissolve 2.99 volumes. At 0° C. 100 volumes of water dissolve 6,886.10 volumes of sulphurous acid gas; and at 15° C. 4,356.50 volumes. At 0° C. 100 volumes of water dissolve 114,800 volumes of ammonia; and at 15° C. 78,270 volumes. Water at a temperature of 45° Fahr. dissolves 2.199 cubic inches of oxygen per gallon; and at 70° Fahr., 1.797 cubic inches per gallon.

The barometric pressure has a feeble influence in causing variation in the amount of oxygen absorbed by water; the variation not exceeding a small fraction of a grain per gallon. Yet in a large river this means a variation in the quantity of oxygen to be measured by tons. River water in summer contains about 4 grains of oxygen per cubic foot; and about 5 grains in winter. Every 10 million cubic feet of water passing over Teddington Weir carry with them 17 1/4 tons of liquefied oxygen, or about 50 tons of liquefied air, when the water is at the temperature of 60° Fahr. In August, 1859, Dr. W. Allen Miller ascertained the proportion of oxygen in the Thames at low water, and found that as the Thames runs through London, the quantity of oxygen in it diminishes as compared with the proportion it contains at Richmond. He discovered that about 12 or 13 tons of oxygen are lost between Richmond Bridge and Somerset House.

Other chemists have since taken up the work; and their results agree tolerably closely. One method of testing the proportion of oxygen in water is by means of hyposulphite of soda—a salt in an inferior state of oxidation to the sulphite. The hyposulphite used is not that employed by photographers, which is properly speaking the thiosulphate of soda. The hyposulphite of soda used in the analysis of water bleaches the ammoniacal solution of oxide of copper; and it deoxidizes indigo, magenta, and iodide of starch. White indigo is made blue by the air in water; but does not do so if hyposulphite of soda is put in the water first, to

absorb the oxygen. When water is made blue by indigo, and hyposulphite of soda is afterward added, the latter has the choice of two substances from which to absorb oxygen, and it deoxidizes the air in the water first. Hence the quantity of hyposulphite used before the liquid is bleached affords a method of measuring the proportion of oxygen in water.

When the liquid is just bleached by adding no more hyposulphite of soda than is necessary for the purpose, it can be made blue by driving down air into it, or by pouring it from one vessel to another. Tests of the Thames water show that at Erith (near the sewage outfall) it contains about 1/2 cubic inch of oxygen per gallon, instead of 2 cubic inches per gallon. But lower down, the proportion of oxygen rises again, until the water is within 10 per cent of its richness in oxygen at Richmond. Thus the considerable power which flowing water possesses of keeping itself sweet and clean is no longer a matter of speculation, but one of positive proof. Still the power, great as it is, may be overtaxed; and it often is overtaxed in some cases when the organic matter is non-living. As to whether it has the power of destroying those minute living organisms which are the germs of certain diseases, there are at present, Dr. Odling admitted, very great differences of opinion among chemists.—*The Journal of Gas Lighting.*

**Vertical Flight of Bullets.**

Experiments have been made in Hartford, Conn., with the vertical firing Gatling gun, in the presence of a number of mechanics, military men, and others interested in gunnery. The inclination of the piece was determined by a combined spirit level and quadrant. At an inclination of fifteen degrees, the time between the discharge and the return of the bullets into the river on the banks of which the experiments were made, was fifty-nine seconds. On an exact vertical fire, the time of return was fifty-four seconds. The force of the return of the bullets—44 caliber rifle—was sufficient to drive them through four inches of pine boards, enough to render any defenses not hombproofs untenable against such a shower.

**MITER BOX.**

The accompanying engraving shows an invention lately patented by Mr. Joseph Cashin, of Newport News, Va. To one edge of the base of the box is attached a side plate having vertical slots, upon opposite sides of which an attached guide bars by bolts or screws inserted in transverse slots, to allow the bars to be adjusted toward or from each other. Between each pair of bars is a pair of slides provided with grooves by which they are held as they slide up and down, and which are connected together by a projection on the face of one fitting in an opening in the other. One of the slides has a beveled end and a notch in which engages a spring catch (Fig. 2) attached to the upper end of one of the guide bars, so as to hold the slides at the upper ends of the slots preparatory to placing the saw in position.

In the base is supported a pair of guide bars that are secured to a plate having a pintle which rotates in a bracket under the base. The lower ends of the bars have flanges by which they are bolted to the plate, which is formed with slots so that the bars may be adjusted. The pintle is prevented from turning by a screw. A pair of slides, similar to those above described, is placed on these bars.

An ordinary hand saw, without the extra back commonly used in mitering, is placed between the slides of the bars on

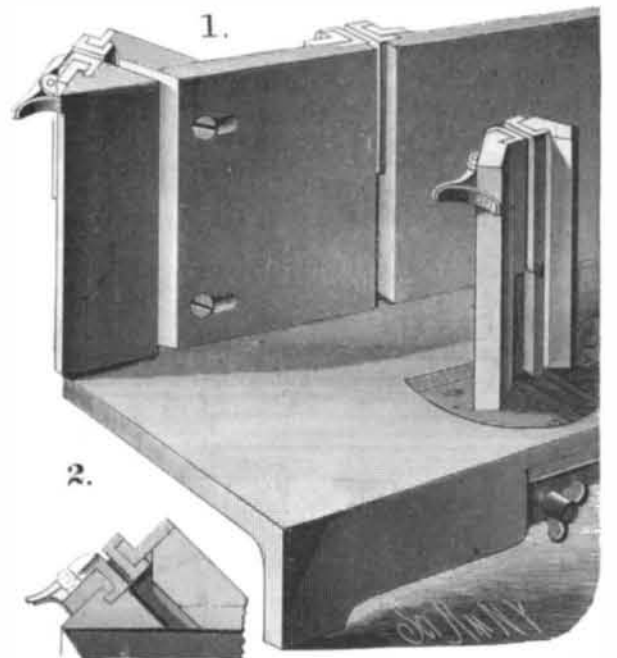

**CASHIN'S MITER BOX.**

the pintle, and between one of the side slots, and is moved up until its thin back rests against the projections. Then, by releasing the catches, the slides will be supported on the saw by the projections, and will follow the saw down in the operation of sawing. The guide bars on the base may be turned to allow the saw to be placed in any one of the side slots. With this construction the saw may be made to cut any desired depth, and the device may be adjusted to any thickness of saw.