

IMPROVED ACOUSTIC TELEPHONE.

The front board, A, of the box is provided with a central aperture. The diaphragm, M, is stretched over the central opening of a board, D, which has strengthening ribs on its under side and along the edges. An annular block of wood, F, whose thickness decreases from the top toward the bottom on the inner as well as the outer side, is placed between the front board and the diaphragm. The upper opening of the block coincides with the central opening of the front board, and the bottom opening is smaller than the opening in the board, D. The bottom edge of the block is pressed upon the diaphragm by bolts, G. In the central opening of the block is a funnel-shaped vessel, H, held in place by

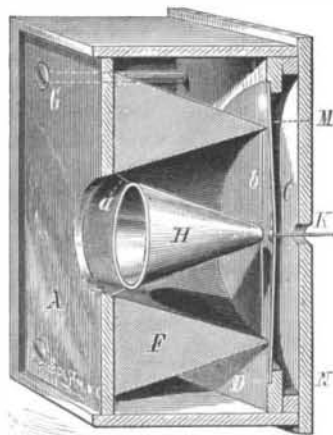

HUSTON'S ACOUSTIC TELEPHONE.

wires, *a b*, at the top and bottom, which hold the lower end of the funnel a short distance from the diaphragm. A button is fastened to the middle of the diaphragm, to which is fastened the wire, K. The funnel concentrates the sound waves and guides them to the diaphragm, thus causing strong and distinct vibrations that reproduce the words very plainly. The diaphragm is formed of alternate layers of skin and a textile fabric.

This invention has been patented by Mr. H. E. Huston, of the firm of Lodge & Huston, of Monticello, Illinois.

The Center-cycle.

We have had brought to our notice, says *Engineering*, a very ingenious apparatus which combines the speed and simplicity of the ordinary bicycle with the stability and safety of the tricycle. This apparatus, to which the inventor, Mr. Edward Burstow, of Horsham, has given the name of center-cycle, is a mechanical roadster, which has the general appearance of an ordinary large wheel bicycle fitted with four smaller supplementary wheels, one pair in front of and one pair behind the center or driving wheel.

Over the center of the large driving wheel is a saddle attached to tubular framing, similar to that in the best bicycles, and the wheel is driven in the ordinary way by means of a pair of cranks fitted with treadles. The steering of the machine is effected by means of a steering handle, which operates, through a curved bar and a Hooke's joint, upon the axle of the forward pair of wheels, which, in its turn, acting through a lever, sets the rear axle to a similar angle, both being in directions normal to the curve along which it is desired the apparatus is to travel. In this respect the action is very similar to that of a roller skate, and is quite as easily and as smoothly controlled.

So far the description would be applicable to an apparatus of the tricycle type, but furnished with five wheels instead of three; but the characteristic feature of Mr. Burstow's invention, and that which makes it superior in several respects to both the bicycle and the tricycle, lies in the fact that not only can the four smaller wheels be turned at will in any desired direction, but they can, each or all, be lifted—while the machine is in action—quite clear of the ground; the apparatus at that moment is instantly converted into a single wheel apparatus, carrying, it is true, for the time the extra weight of three idle wheels, but having in compensation but half the friction of a bicycle, and possessing in the four suspended wheels, which can be dropped at any instant, a reserve or element of stability which makes the apparatus exceptionally safe at the highest speeds.

In practice the apparatus is adjusted so that the principal weight is borne by the large center wheel, and the four side wheels are but barely grazing the ground; when in this condition the machine can at any moment be made to run on the four little wheels, or on the center wheel, or upon different combinations of the center and side wheels.

From the above description it will be observed that Mr. Burstow's apparatus is singularly unaffected by roughnesses of, or small obstructions on the road; for the effect of an obstruction on the center wheel is to momentarily lift that wheel, and the machine runs past the obstruction on its side wheels, which then carry the weight; and similarly, if the side wheels run against an obstruction they become lifted thereby from the ground, and the center wheel receiving

the weight carries the apparatus past the impediment. The rider has an obvious advantage in sitting directly over the center of the driving wheel; he is thereby not only in the best possible position for propulsion, but his center of gravity being over the center of base he is in the position of maximum stability.

The Burstow center-cycle has been employed by the post-masters of Horsham and Saxmundham with great success, having been used by the letter carriers and telegraph messengers for twelve months in those districts without a single accident being recorded, and it has been employed by local bakers, with equal success, for delivering bread, and thereby saving the expense of a horse and cart.

Cigar Making at Seville.

A letter from Seville describes the government cigar factory of Spain. The factory is 700 feet long, and almost as wide, and very dirty. At the time it was visited by the writer, there were 250 young girls in the vestibule, making cigarettes; in the next room were 100 other girls engaged in the same occupation, and on the next floor 3,000 women as close as sardines in a box, in a single room, making cigars, some of them having their babies with them not a month old, while dogs were lying on the tobacco stems. The women were divided into sevens at each table, three on each side of the mistress at the top. Around each table were shelves against stone pillars, on which lay children's shoes, socks, and clothes. The air was stifling, and the buzz of conversation was now and again broken by the wailing of the babies. The flooring was so dilapidated that it was possible for an incautious visitor to fall through. Two other side apartments 100 feet long were packed with laborers. The factory consumes 10,000 pounds of tobacco per day and employs 5,000 persons, who receive 50 cents per day for 12 hours' work. The matron at each table gets her pay from the women she commands.

IMPROVED CAR COUPLING.

The accompanying engraving shows an invention recently patented by Mr. W. H. Thurmond, of Forsyth, Georgia. The draw bar has a longitudinal vertical recess provided with backwardly inclined surfaces, the forward one of which forms a shoulder, as indicated in the sectional drawing, Fig. 1.

On the upper part of the bar are formed two ears, which are perforated transversely to receive a rock shaft that is worked by an arm at the side of the bar. Secured to the rock shaft between the ears is an arm, *e*, Fig. 1, extending down through a slot in the longitudinally movable thrust bar, *d*, fitted into the recess in the base portion of the draw bar.

Pivoted to one ear of the bar is a coupling hook, whose form is clearly shown at *a b* in the cuts. Through an aperture in the upper part of the bar is a latch, *c*, having a movement in a vertical line.

When the thrust bar is moved back by means of the rock shaft, *e*, the latch, *c*, is raised, and drops in front of it and prevents its forward motion. The coupling hook can then be moved to the position shown in Fig. 3, the bevel at *b* enabling it to lift the latch. While the latch is raised the thrust bar drops forward to the position shown in Fig. 1. In the act of coupling the hook is turned upon its pivots, the circular rear portion raising the latch and pushing the thrust bar back and up. When it has assumed the position

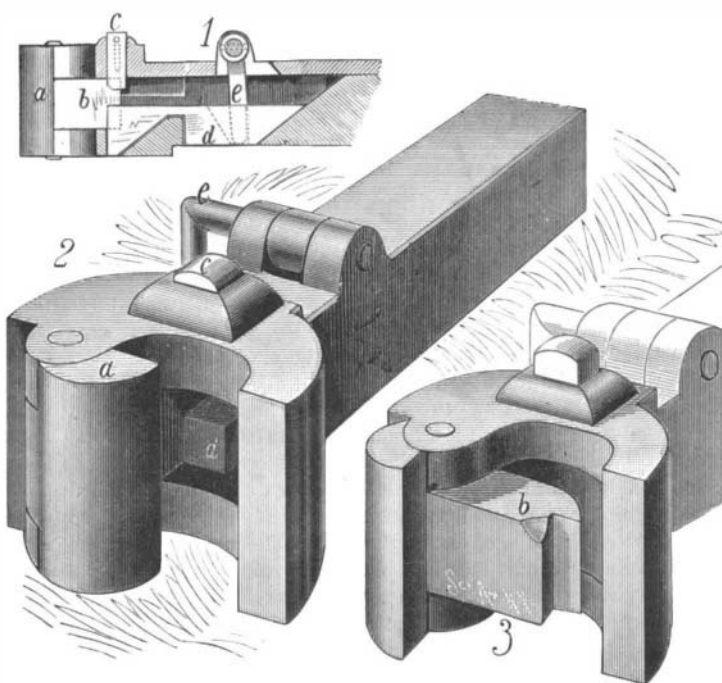

THURMOND'S IMPROVED CAR COUPLING.

shown in Fig. 2 the rear part has passed the thrust bar, allowing it to drop forward, where it prevents the return of the hook.

All the working parts of the coupler are protected, since the bumping is upon the outside of the draw head. The cars cannot be uncoupled until the thrust bar has been moved back sufficiently to allow the hook to turn.

A SPOONFUL of kerosene oil put into cold starch will prevent the iron from sticking.

IMPROVEMENT IN THE LECLANCHE BATTERY.

The Leclanche Battery Co., of No. 149 West 18th Street, New York, have introduced a new form of jar and cover for the well known prism battery, an illustration of which we give herewith. The cover rests upon a shoulder inside of the jar, which is oval in shape, the rim of the jar above the cover being concave in shape. The cover when in place closes the jar sufficiently tight for ordinary purposes; but, if desired, it may be hermetically sealed by pouring on the

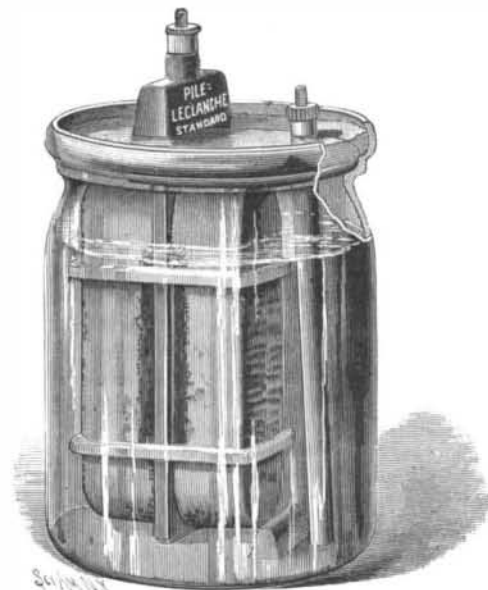

PRISM BATTERY, COMPLETE.

cover melted wax, which will spread over the cover, run into the concavity of the rim, and be held firmly in place, thereby effectually sealing the jar. Any kind of wax may be used for the purpose, but paraffin is preferable on account of the ease with which it can be removed. The cell can be unsealed with an ordinary pocket knife whenever necessary to renew or clean it. The latter process, however, will scarcely be necessary, as the paraffin prevents the salts from climbing up and fouling the cover. A cell thus sealed can be transported on boats, cars, and other vehicles without danger of slopping over the liquid. The adoption of the new jar and cover is a manifest improvement, and will undoubtedly add to the reputation of this famous battery. The jar and cover have both been patented.

Successful Artifice in Discovering a Secret.

Mr. F. J. R. Carulla, F.C.S., general manager of the Landore Siemens Steel Works, recently delivered a lecture on "The Steel Age," in which he referred to the experiments of Huntsman, the Doncaster clock maker, who perfected the process of melting blister steel in crucibles, and producing a homogeneous ingot, about 1740. Huntsman endeavored to keep his process secret, with the following result: "One cold winter's night, while the snow was falling in heavy flakes, and the manufactory threw its red glare of light over the neighborhood, a person of the most abject appearance presented himself at the entrance, praying for permission to share the warmth and shelter which it afforded. The humane workmen found the appeal irresistible, and the apparent beggar was permitted to take up his quarters in a warm corner of the building. A careful scrutiny would have discovered little real sleep in the drowsiness which seemed to overtake the stranger, for he eagerly watched every movement of the workmen while they went through the operations of the newly discovered process. He observed first of all that bars of blistered steel were broken into small pieces two or three inches in length, and placed in crucibles of fire clay. When nearly full, a little green glass broken into fragments was spread over the top, and the whole covered over with a closely fitting cover. After a lapse of from three to four hours, during which the crucibles were examined from time to time to see that the metal was thoroughly melted and incorporated, the workmen proceeded to lift up the crucible from its place on the furnace by means of tongs, and its molten contents, blazing and sparkling, were poured into a mould of cast iron previously prepared; here it was suffered to cool, while the crucibles were again filled and the process repeated. When cool the mould was unscrewed and a bar of cast steel presented itself, which only required the aid of the hammerman to form a finished bar of cast steel. How the unauthorized spectator of these operations effected his escape without detection tradition does not say, but it tells us that before many months had passed the Huntsman manufactory was not the only one where cast steel was produced."

A Dairy Exhibition at Munich.

The American Government has received an invitation to participate in an exhibition of dairy products at Munich, in October, 1884, under the management of the general committee of the Agricultural Union of Bavaria, in connection with the Bremen Dairyman's Union.

Sound Motors.

Mr. Edison's "motophone," in which the vibration of a telephone plate or "tympan" under the action of the voice is made to work a ratchet wheel round, anticipated the apparatus of Dr. Dvorák, of the University of Agram, in Croatia. Through the kindness of Mr. W. H. Preece, F.R.S., we have, says *Engineering*, seen a set of Dr. Dvorák's apparatus in action. The source of sound is a tuning fork kept in vibration by electro-magnetism and mounted on a resonance box. The open mouth of this box or chamber is the source of sound, and the sound mills are placed in front of it. One of these consists of a cluster of light glass balls suspended from a cross-shaped frame which is pivoted on a needle point. Each ball has a little nipple blown on its side, the nipple being pierced with a hole. The holes are on the same face of each ball round the cluster, that is to say, they all point in one way and receive the sound impulses one after another as the group of balls revolve, just like the sails of a windmill. The wall of the balls opposite the nipple, is, of course, entire, and the motion is due to the reaction on it. Another mill consists of four little stiff flags or plates of paper-like material pierced with holes, and suspended from four crossarms carried by a pivot as before. The holes are so pierced as to make small open nipples as before on a needle point. The holes are 0.6 centimeter apart. When placed before the resonating cavity, with the smaller ends of the nipple-like holes toward it, the card is repelled and attracted if the back of the card presenting the wider openings of the nipple is placed before the resonator. A similar mill is made with plane flags without holes, and the motion is intensified by placing between it and the cavity of the resonator a brass ball, or Helmholtz resonator, with open nipples at opposite diameters. These nipples are placed in line with the resonating cavity and the mill, the larger nipple being next the cavity. When a lighted paper or the hand is held behind the Helmholtz resonator, a distinct puff of wind is felt to issue from the nipple farthest from the resonator; and it is this puff of wind which, impinging on the vanes of the mill, causes it to rotate. A screen pierced with 100 conical holes may also be placed between the ball resonator and the mill in order to distribute the breeze. Another of Dr. Dvorák's rotators, also very interesting, is a flat cylindrical paper box, of glazed paper, having four projections on its sides, each carrying a short open tube of paper. It is a resonator with four openings, and, when suspended by a silk thread from a standard in front of the sounding box, begins to whirl round.

Stealing a Ride in England.

A man wishing to travel free from Wolverhampton, England, to Liverpool, procured two stout pieces of rope, which he fastened to the axles of a railway carriage, leaving a noose at the end of each. Into one noose he put his legs while he inserted his shoulders into the other. In this position he hung when the train started. The train was an express, and did not stop until Crewe was reached, which is about 70 miles from Liverpool. He was rather uncomfortable when the train began to move, but when it got into full swing he had real torture, and when he reached Crewe he was nearly dead with fright. Here he was taken into custody. To the magistrate who adjudicated on the case he explained that his sensations when swaying to and fro were something awful, and the effect of the sleepers as they rushed past him nearly robbed him of reason, and he "was afraid that every moment the rope would slip from his shoulders and hang him." The magistrate decided that he had had enough punishment, and, remarking that he was not likely to repeat the experiment, sent him about his business.

This must be a good deal worse than riding on a truck, which American tramps sometimes do.

Why Apprentices are Scarce.

A contemporary writer says it is principally because of the conceit of weak and foolish parents, who could not think of allowing their boys to soil their hands with manual labor, or tarnish their pedigree by associating with common workmen. Many and many a young man have I known whose aptitudes called to him with all the imperious demands of instinct to learn a trade, but he was prevented from doing so by his parents, who preferred to see him filling the more important and dignified position of clerk, often working fifteen hours a day for \$15 per month, and sometimes yielding to the small temptation to leave unpaid his tailor's and washerwoman's bills. Or if he escaped the clerkship, he was almost sure to be found among the luckless ninety and nine professional men who stand off and eye with green envy the one in the round hundred who has made a success. It is not lack of attention to the new workman that is lowering the standard in mechanical trades, but the folly of parents in closing the doors of the trades in the face of their sons, and in the absence of good material we get bad. It is very often the case that we get hold of a boy who has but few or no qualifications, natural or acquired, for a trade, but he can probably make more money at that than at common labor, and as we can get no better, we have to do the best we can. There is no doubt but we are getting poorer subjects every year for apprentices for this very reason. But we can reach a point so low that it is impossible to go any lower, and I believe we have about reached that point in some lines of business. Some parents, and boys too, are at last getting their eyes opened. They are learning that they cannot plant duds and raise men. Many

bubbles have been pricked, and much gilding has worn through. Labor is becoming more dignified, because more than ever before is it wedded to thought. The manual training schools which are springing up in nearly all of our large cities are giving instruction to many boys whose parents, perhaps, would not at the start consent to them entering the shops. These schools are doing a good work in teaching the principles of trades, in fostering a genuine love for mechanics, and in pointing out the way to the special field where the young man can labor with the assurance of receiving his highest reward. With such brightening prospects as the work of the manual training school warrants, we see no reason for fearing that the race of good workmen in any trade will soon die out. On the contrary, we believe we will see mechanics increasing in numbers and skill from year to year.

IMPROVED HAND TRUCK.

In the invention herewith illustrated, recently patented by Mr. C. F. Stremel, Cresco, Iowa, a rod is pivoted to a standard secured to the upper cross bar of the truck. The free end of the rod is forked, and the ends of the prongs are bent down so as to form hooks. The pivoted end is flattened and provided with a series of apertures through either of which the pintle can be passed. This end projects beyond the pivotal point toward the handles of the truck, and serves as a handle by which the hooks can be disengaged from the package. When a bundle of barbed or other wire

**STREMEL'S IMPROVED HAND TRUCK.**

or any bundle is to be loaded on the truck, the forked end of the rod is raised, the truck is put in position for loading, and the forked end is then lowered on the bundle, holding it securely in place. By raising the forked end of the rod the bundle is released. The device can be adjusted to trucks of any common size, and can be attached or detached very quickly.

The Cable as It Is.

The cable system for passenger traffic as applicable to the streets in New York city is thus criticised in the *Brooklyn Union* by one of its correspondents, who evidently knows whereof he writes:

The so-called Rapid Transit Commission for the city of New York, while proposing an extended plan for new railways in its streets, seem to have assumed that the cable, or rope traction, is the method best adapted for street transit. As little appears to be known by the public of the operation of this system, it is important that it should be explained somewhat in detail. Its difficulties and objections are so apparent to any one investigating the Chicago cable railway, that with a full knowledge of them the citizens of New York would not consent to its adoption in their streets. Its most important feature is that of a rope running on permanent bearings under the ground, midway between each pair of rails or tracks. Movement is given to this rope by engines located adjacent to the tracks, by means of large cylinders or drums connected with them, around which one end of the loop of wire rope passes, the rope being continuous, and the other end a loop, passing around a similar cylinder at the outer end of the roadway. Be it any number of miles in length, the rope must be endless. Between these two extremes and around the cylinders the rope is in constant motion at a speed fixed at the engines. It may be three or six miles per hour, but cannot be moderated or increased between any two cylinders; it must be constant at the speed given at the cylinder near the engines. It cannot be graduated to the variations of speed in street traffic.

Movement is communicated to the cars by what is called a grip, which is an iron bar depending from a grip car, so called, placed in advance of and to which are attached the passenger cars. This iron bar or grip rod is in contact with the cable constantly. The rope passes through a loop or ring in the lower end of the grip rod loosely, when cars are at rest, but movement is given to them by tightening the grip around the rope, when they instantly acquire its velocity. When a stop is desired the grip is released, the brakes are put on, and momentum checked.

It will readily be seen that a rigid system operated from a remote center involves insuperable difficulties for the ever varying conditions of street traffic. When the rope breaks or is thrown out of its bearings, the movement of cars is suspended—which has often occurred in Chicago—and cannot be released until the rope can be repaired or spliced, often requiring several hours, stopping not only a single car, as by other systems, but all between any two cylinders—it may be 10 or 100 cars, and it may be through any number of miles. All the cars moving in either direction in that circuit are compelled to stop until the rope is repaired, or be

moved by horses, to which the Chicago road has often been obliged to resort. This difficulty prevents the continuity of service which is indispensable for any of the streets of this city.

The crossing of other tracks is not accomplished successfully at Chicago, as the grip must for the time be released to pass the intervening obstruction, and its connection again becomes uncertain, and involves risk, as momentum must be sustained, and cannot be checked suddenly should some obstacle come in its way.

The grip rod connects with the rope through an open slotway, which must be continuous through the center length of the road, between each pair of tracks. This slotway is a permanent opening, five-eighths inch wide in the Chicago road, which has proved just wide enough to let in the calk of a horse's shoe and results in violently tearing off the shoe and injures the hoof and ankle, this having often occurred. The construction of this system of road places a series of contingencies in the center of traffic which are constant and liable to interrupt business upon the streets, besides destroying all continuity of service on the road itself; all being governed by a fixed movement remote from the car, but holding it firmly in its grasp, and forcing all the traffic of the street to its rigid laws. Collisions are of frequent occurrence, and unavoidable with a system which cannot be graduated to street travel, and which can only move at all by a sudden change from a full stop to the speed of the cable; be it three miles or six miles an hour, a jerk is inevitable.

While the operation of the system is subject to many difficulties not enumerated, its method of construction is a serious consideration. In Chicago trenches have been dug four or five feet deep, which occupy the space between each pair of tracks; they are lined with concrete, made of broken stone and cement, in which trenches the iron frames and wheels are fixed on which the rope moves. These trenches or sewers are permanent, have manholes at intervals, and are accessible for repairs, and are always open through the slotway to the street surface, and many men are constantly engaged in removing the substances which fall through the slotway, which are taken out through the manholes referred to. This space may perhaps be spared for such uses in a street as wide as State Street, Chicago, but is entirely impracticable on the narrow streets of New York or Brooklyn, now so largely occupied with underground complications.

It is pertinent to inquire whether rapid transit is possible by such a system on our streets. The legal and the safe limit of speed on the surface is six miles per hour. It is clear that the rope traction system cannot maintain this average as even as the horse cars can. The frequent full stops and the impossibility of accelerating speed after such delays will render the average much below that. At a rate of speed above six miles its momentum rapidly increases and becomes more difficult of control—in fact, has proved an element of great danger. In Chicago fourteen persons have been killed by the system in one year, as shown by the admission of the president of the Chicago cable road.

It is evident that the rope traction system for street railways is uncertain in its operation; that it cannot be relied upon for constant service; that it cannot graduate its speed to the requirements of street traffic; and that it is extremely unsafe unless the portion of the street occupied by its tracks is given up to its use, and other streets at its crossing compelled to yield to its movements.

It is to be hoped that no construction of this system will be allowed in our city without a thorough investigation of existing facts, which will certainly prevent the consummation of any plans for the adoption of rope traction by any system yet known, with the consent of the public authorities.

The Patent Office Surplus.

A correspondent suggests that the surplus revenue of the Patent Office be employed to furnish inventors with free subscriptions to the *Official Gazette*; the writer being under the erroneous impression that the Commissioner of Patents is puzzled to know how to dispose of the accumulation of money. The truth is that the Commissioner has no power to expend a dime more than Congress directs in its annual appropriations; and the Legislature has reduced the clerical force of the Patent Office so greatly that the Commissioner is unable to transact some of the ordinary business of the office with proper dispatch. This hostile legislation is doubtless intended like other Congressional bills to damage and annoy inventors, and manufacturers who hold patents. How long the latter will permit themselves to be made the sport of the politicians remains to be seen.

An Onion Disease.

Since parasites do infest everything organic, we are not surprised to read in the *Rev. Scientifique*, January 5, 1884, that M. Joannes Chatin has found a parasite in the common onion that gives rise to disease. M. Pasteur, who has examined it, finds it similar to the parasite of mildew in wheat, but with less vitality. The affected plants, it is said, should be pulled up and burned.

PATENT applied for: Cheap burglar alarm.—Drive a headless nail into the casing over any door, and after closing the door hang a tin pan on the nail when you go to bed. That is to say, do all this if you are naturally timid and want a cheap burglar alarm that will work every time.—*De-troit News*.