

**How Voltaire Cured the Decay of his Stomach.**

In the "Memoirs of Count Segur," there is the following anecdote: "My mother, the Countess de Segur, being asked by Voltaire respecting her health, told him that the most painful feeling she had arose from the decay in her stomach and the difficulty of finding any kind of aliment that it could bear. Voltaire, by way of consolation, assured her that he was once for nearly a year in the same state, and believed to be incurable, but that, nevertheless, a very simple remedy had restored him. It consisted in taking no other nourishment than yolks of eggs beaten up with the flour of potatoes and water." Though this circumstance concerned so extraordinary a person as Voltaire, it is astonishing how little it is known and how rarely the remedy has been practiced. Its efficacy, however, in cases of debility, cannot be questioned, and the following is the mode of preparing this valuable article of food as recommended by Sir John Sinclair: Beat up an egg in a bowl, and then add six tablespoonfuls of cold water, mixing the whole well together; then add two tablespoonfuls of farina of potatoes; let it be mixed thoroughly with the liquid in the bowl; then pour in as much boiling water as will convert the whole thing into a jelly, and mix it well. It may be taken alone or with the addition of a little milk in case of stomacic debility or consumptive disorders.

**FIG IRON BREAKER.**

Among the exhibits at the American Institute Fair this fall, no machine attracted more attention than "Blake's pig iron breaker," exhibited by the Blake Crusher Company, of New Haven, Conn., the original patentees and manufacturers of the "Blake challenge rock breaker" of world-wide reputation. The pig iron breaker was designed and built in response to repeated solicitation from foundrymen and others for a machine to break pig iron into pieces, seven to eight inches in length, for foundry purposes.

Heretofore this has been done by hand, either by lifting the pig bodily and throwing it down on a V-shaped mass of iron or by striking with a sledge hammer. The work, especially in the case of the tougher varieties of iron, was necessarily severe, slow, and expensive. Repeated blows with a heavy sledge hammer wielded by a practiced hand would often fail to break a pig of iron. The pig iron breaker is strong and effective, and so simple that the illustrations of it which we present leave little to be desired in the way of explanation. The pig is fed in on an inclined or yielding trough, furnished with rolls, passed over a V-shaped knife to an adjustable stop on the end of the sliding head, A. This sliding head is provided with two knives, equidistant from the center knife on which the pig is supported, and has a motion of two inches.

The sliding head descends, and a piece of the pig extending from the center bearing or knife to the "stop" is broken; it ascends, the pig is struck forward, and another piece is broken from the pig by its subsequent descent. In this way successive pieces are broken from the same pig with great rapidity and ease, with an expenditure of but from two to three horse power. In fact the product of the machine is limited only by the rapidity with which it is fed. Iron can be broken as rapidly as it can be discharged from the cart or car which brings it to the foundry yard.

The machine may be stationary and run by belt or by small engine bolted to the side of its timber frame, to which steam is conveyed by pipe from the boilers at the works where it is used, or it can be mounted on a car with engine and boiler and be moved on a track along the piles of iron to be broken.

The Blake Crusher Company is now mounting one in this way for the Albany and Rensselaer Iron and Steel Company, Troy, N. Y., where 500 tons are broken daily for making Bessemer steel. At present the pigs are broken by hand into but two pieces.

It is thought that the breaking of pigs into a greater number of pieces by machine will secure a more intimate admixture with the fuel and fluxes in the cupolas, greater economy

not only in heating but in melting, and a greatly increased product of steel in the same number of hours.

The machine is the invention of Theodore A. Blake, Mining Engineer and Secretary of the Blake Crusher Company, New Haven; was patented May 3, 1881, in the United States, also in England. It received the award of "medal of excellence" at the recent fair of the American Institute, where the Blake Crusher Company was awarded the semi-centennial gold medal for their challenge rock breaker.

**IMPROVED SHAFT COUPLING.**

We give an engraving of an improved shaft coupling lately patented by Messrs. J. B. Dyson & S. K. Paramore, of New Britain, Conn. It is very simple, easily constructed and easily applied, and when it becomes necessary to dis-

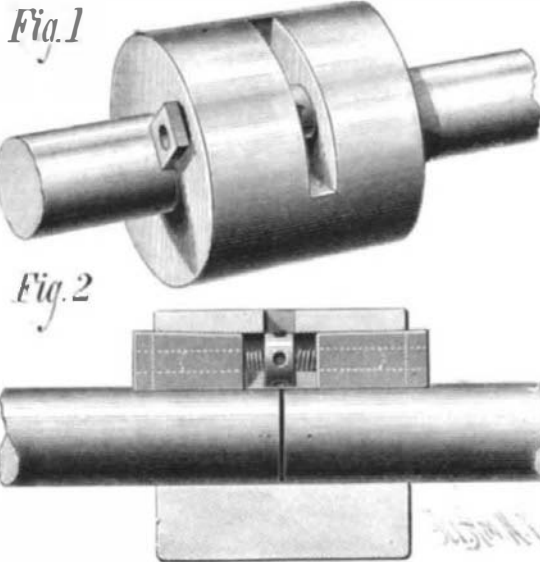
**NOVEL SHAFT COUPLING.**

connect the shafts it is easily removed. The adjacent ends of two shafts are inserted in a sleeve which fits the shafts and has a longitudinal groove formed in its inner surface. This groove is tapered or inclined on the top from its ends toward its center, as shown in the sectional view, Fig. 2.

Two keys, corresponding in shape to the groove, fit against the inclined bottom of the groove. The inner sides of the keys are concave or flat to rest upon the sides of the two shafts. One key has a right screw hole and the other a left screw hole cut through it, into which fit the threads of the

direction the keys are pushed outward, releasing the shafts. It will be noticed that the sleeve is slotted transversely opposite the collar of the screw to allow the lever or operating handle to be inserted in the holes in the collar and turn the screw. It is unnecessary to mention the advantages possessed by this coupling, as it can readily be seen that it is in every particular a practical thing.

**The American Public Health Association.**

The American Public Health Association, in session at Savannah, Georgia, December 1, elected the following officers: President, Professor R. C. Kedzie, of Michigan; First Vice-President, Dr. Ezra M. Hunt, of New Jersey; Second Vice-President, Dr. Albert L. Gehon, U.S.N.; Treasurer, Dr. J. Berrier Lindsley, of Tennessee; Executive Committee—Dr. James E. Reeves, West Virginia; Dr. Stephen Smith, New York; Dr. Thomas L. Neal, Ohio; Dr. J. G. Thomas, Georgia; Edward Fenner, Louisiana; and Dr. John H. Rauch, Illinois. The papers read at this meeting have covered, as usual, a wide range of topics relating to public sanitation. The meeting next year will be at Indianapolis.

**The King of Siam to the United States.**

General Halderman, our Consul General in Siam, has received from His Majesty the King of that far off country a promise to furnish a memorial stone for the Washington National Monument.

**Another Great Ocean Steamer.—The Servia.**

The new Cunard steamship Servia arrived at this port Dec. 7, after a stormy passage of thirteen days. For the first seven days she had to buffet severe head winds, at times approaching a hurricane. Her best day's run was on the 6th, when she made 406 miles. Her gross tonnage is 8,500 tons; engine power, 10,000 horse power.

The length of the Servia is 533 feet; breadth, 52 feet; depth, 44 feet 9 inches. Her cargo capacity is 6,500 tons, with 1,800 tons of coal, and 1,000 tons water ballast. She has a double bottom on the longitudinal bracket system. The anchor davits are 8 inches and the chain cable pipe 23 inches in diameter. The propeller shaft weighs 26½ tons, and the propeller, boss, and blades are 38 tons in weight. The machinery consists of three cylinder compound surface condensing engines, one cylinder being 72 inches and two 100 inches in diameter, with a stroke of piston of 6 feet 6 inches. Her boilers are seven in number, 6 of them double and 1 single ended, all made of steel. She has 39 corrugated furnaces. There are 168 state rooms, with accommodation for 450 first class and 600 steerage passengers, besides a crew of 200 officers and men.

The ship is divided into nine watertight bulk heads, and carries twelve life-boats. In the engine and boiler spaces are water-tight doors which can be shut from the upper deck in case of accident in about two seconds. The keel of the ship has five thicknesses, making a total thickness of 6¾ inches. The riveting was done by Tweedell's hydraulic riveter, and all the frames and beams of the vessel were riveted by this process. The lower deck is of steel, with a covering of teak above the engine and boiler spaces, and the upper and main decks are both of steel with wood coverings. All the deck houses and deck fittings, the positions of which render them liable to be carried away during heavy weather, are riveted to the steel decks underneath.

The Servia is equipped with Muir & Caldwell's steam steering gear, steam winches, a steering gear independent of that managed by steam apparatus, and Sir William Thomson's compasses. Every separate passage in the vessel

is ventilated by a series of ventilators. The cabins and saloons are heated by steam. The construction of the Servia was superintended by Captain Watson, of the Cunard service, and Mr. William Muir, the company's engineer at Glasgow. In every part of the ship the most advanced scientific improvements have been adopted. The very best material has been used.

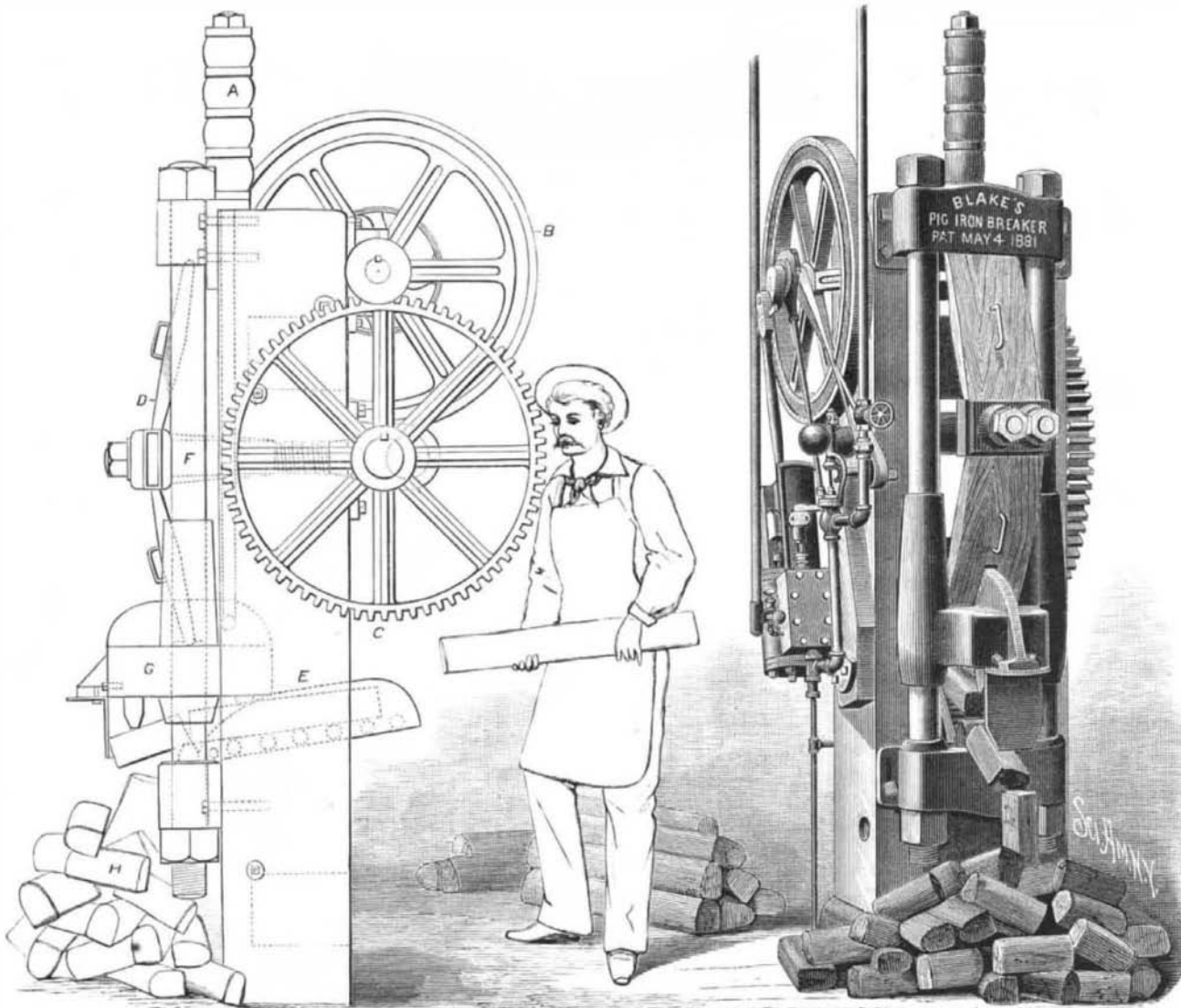
**BLAKE'S FIG IRON BREAKER.**

right and left screw, whose middle part has a collar formed upon it in which are formed a number of radial holes to receive the end of a pin to serve as a lever or handle for turning the screw.

When the screw is turned in one direction the keys are drawn inward toward each other, and clamp the ends of the shafts securely, and when the screw is turned in the other