

operation to which the pulp is subjected first after the grinding and crushing by the rollers. In the immense circular vats here shown a shaft revolves to which is attached arms of particular shape and form, which has been a matter of much experiment, to churn up and separate the different constituents of the grain, an operation which is now conducted far more expeditiously and efficiently than was formerly the case. A smaller view on the same page shows the interior of a nicely furnished hall which the establishment furnishes for the use of its employes for holding meetings, etc., and which is christened "Firemen's Hall," as being the headquarters of a volunteer organization of that kind among the men employed. In the papering and drying room, also shown here, the work is all done by men, although a large force of women and girls find employment in the establishment; and it is perhaps as well to remark here that the firm exercise the utmost care in the selection of their employes, not only as to their personal character, but insisting on the most thorough neatness and cleanliness in every department.

The main buildings of this immense establishment are all of stone, brick, and iron, some portions being seven stories high, making a total frontage of 800 feet by 200 feet deep. Besides these there are other large buildings, such as the box factory, storehouses, machine shops, etc. The works are now making at the rate of 21,500,000 lb. of starch and prepared corn annually, or about 35 tons per day, giving employment to upwards of 950 operatives. The Kingsfords have been continuously engaged in the manufacture of starch for about half a century. The Oswego Starch Factory was incorporated in 1848. Dr. S. Willard, of Auburn, N. Y., was elected President of the Company at its first organization, and has held that office continuously to the present time. A. G. Beardsley, Esq., of Auburn, N. Y., is the Secretary and Treasurer of the company. T. Kingsford & Son is the style under which the manufacturing business is carried on at Oswego, and E. C. Chapin, of 146 Duane street, New York, who is also one of the Board of Trustees, is the general agent.

**IMPROVED STREET LAMP.**

We give an engraving of an improved street lamp recently patented by Mr. John Stewart, of Chicago, Ill. The invention relates entirely to the frame of the lamp, which is made of cast, malleable, and sheet metal. In external appearance it is much like the ordinary lamp, but it is better calculated to resist the wind and other forces which frequently destroy the common lamp.

The socket fitting the lamppost and the base plate of the lamp frame are made in one casting, and the sides of the base plate are provided with flaring flanges having at the corners sockets for receiving the malleable iron corner pieces which are fastened by riveting, as shown in Fig. 2, which represents a portion of one of the corners in section.



STEWART'S STREET LAMP.

These corner pieces are angled to receive the glass, and are beaded at the outside corner to give them strength and rigidity. Small thin tongues project from the angle, and are

bent over the edges of the glasses to retain them, as shown in Fig. 3. The upper ends of the corner pieces are soldered to a sheet metal frame, which supports the upper glasses and the chimney. The door frame, of tin, is hinged to the upper frame of the lamp so as to swing vertically, and is provided with a small bolt at the bottom, which is easy of access, and will hold the door locked by its own gravity. The hinges are made entirely of brass, and cannot therefore corrode, so as to interfere with the opening or closing of the door.

The inventor says that the lamp sets perfectly solid on the post, and is entirely free from the warping and twisting so common to the ordinary lamp and so destructive to the glass. We understand that there are now about one thousand of these lamps in use in Chicago giving excellent satisfaction.

For further information address Mr. John Stewart, Department of Public Works, Chicago, Ill.

**AUTOMATIC SAFETY CYLINDER COCK.**

The improved safety valve and cylinder cock shown in the annexed engraving is the invention of Mr. Thomas J.

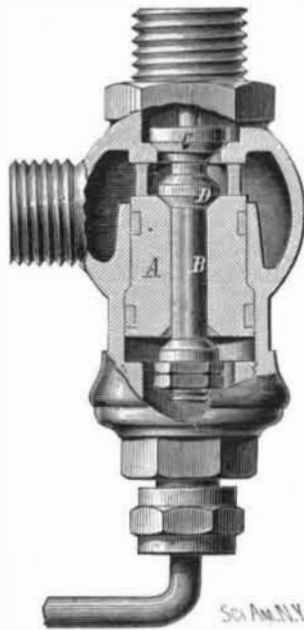

PARADINE'S CYLINDER COCK.

Paradine, of Erie, Pa. It is capable of letting the water of condensation out of a steam cylinder without waste of steam, and is a perfect safeguard against injury to the cylinder by an accumulation of water.

The safety valve and exit cock are arranged in a casing connected directly with the cylinder and communicating with the steam chest by a small pipe entering the lower end.

The safety valve, A, has two seats in the casing, one above, the other below the lateral discharge opening of the casing, and it is pressed upward by steam acting on its lower end, the difference in the area of the two ends being sufficient to secure this result. The valve, A, is bored longitudinally to receive a spindle, B, carrying at its upper end two valves, C D, which are seated in the valve, A, above and below a chamber in the upper end of the valve. The lower end of the spindle, B, is also provided with a valve which has its seat on the lower end of the valve, A. The upper valve, C, is somewhat larger in area than the other valves attached to the spindle, and controls the escape of water from the cylinder.

Under ordinary conditions the pressure of steam on the lower end of the valve, A, will hold it to its seat, but when an extraordinary pressure is brought to bear upon it, as, for instance, when there is more water in the cylinder than the clearance will contain and the piston is just completing its stroke, the valve will be forced from its seat, and the water will escape through the lateral opening in the casing. In working regularly, when the steam is acting on the piston, it also presses the valve, C, to its seat so that neither steam nor water can escape, but when the steam exhausts the pressure on the valve, C, is less than that on the lower end of the spindle, B, consequently the spindle is forced upward and the valve, C, is opened, allowing the water to escape. When steam is shut off from the engine, the valve, A, will drop of its own gravity and allow all of the water in the cylinder to drain out.

Two circumferential grooves formed in the valve, A, are filled with wicking or other packing to prevent grit from working into and around the valve.

The working of this valve is entirely automatic, and it is claimed by the inventor that it is less expensive and more durable than ordinary cylinder cocks. The inventor informs us that he has had this valve at work on a pair of large engines day and night for fifteen months without once failing or showing signs of wear.

Further information may be obtained by addressing the inventor as above.

**Whaling on the Pacific Coast.**

According to the present practice of whalers the blubber is chopped off at sea and the rest of the carcass is left to sink or float as it may until it decays or is devoured by sharks and birds. A less wasteful system has been adopted

by a company at San Francisco, which has organized a whaling and fertilizer industry, to be carried on at that point and along the coast.

The first vessel for whale hunting has just been finished. It is a screw steamer, 65 feet long and 16 feet wide, completely decked over, and very strongly built. It is fitted with two compound engines, and will carry coal for a run of thirty days, to enable the search for whales to be prosecuted along the Alaska shore if necessary. The whales are to be killed by the whaling rocket or bomb lance. They are then to be towed to the reduction works on shore, where the carcass will be treated by an improved process, which utilizes every part. In this process the whale is cut up, without separating blubber or flesh, and digested by steam at high pressure in large iron tanks. The process requires about eight hours, when the oil is drawn off and the residue of flesh and bones is taken out, dried, and ground together to produce a fertilizer. Three digesters have been set up, each large enough to hold a ten foot section of a whale, and three "tries" can be made in a day.

**ENGINEERING INVENTIONS.**

Mr. Robert E. Greenwell, of Osage Mission, Kan., has patented improvements in railway joints of that form in which a set of bolts project through the fish plates and have ends slotted lengthwise to receive a key which is driven in in a plane parallel with the bolt.

A machine for deepening river channels has recently been patented by Mr. Thomas B. Taylor, of Mount Meigs, Ala. This machine is so constructed as to deflect the current of a river downward, and thus cause the current to deepen the channel of the river.

A device for insuring a more perfect combustion than is usual in the fire boxes of steam boilers, evaporators, etc., has been patented by Mr. John Mailer, of San Francisco, Cal. The invention is an improvement upon the device for which Letters Patent No. 219,283 were granted to the same inventor, September 2, 1879.

Mr. Frank Laufkotter, of Collinsville, Ill., has patented an improved safety stop for elevators, buildings, mine shafts, and other purposes, so constructed as to stop the elevator cage and hold it securely should the hoisting rope break.

**Ice without Freezing.**

A new skating surface, called "crystal ice," has been invented by Dr. Calantarients, of Scarborough, England. Considering that after all ice is merely a crystalline substance, and that there is no lack of substances that are crystalline at ordinary temperatures, Dr. Calantarients experimented with a variety of salts, and after a time succeeded in making a mixture consisting mainly of carbonate and sulphate of soda, which, when laid as a floor by his plan, can be skated on with ordinary ice skates; the resistance of the surface is just equal to that of ice, it looks like ice, and indeed when it has been skated on, and got "cut up" a little, the deception is quite astonishing; a small experimental floor has been laid in the skating rink at Prince's, and has proved so successful that no doubt a large floor will be laid there or at some other convenient place in the autumn. This floor will obviously have great advantages, both over artificial ice floors, which are very expensive indeed, and over floors for roller skating. The surface can at any time be made smooth again by steaming with an apparatus for the purpose, and the floor itself, when once laid, will last for many years. The mixture of salts used contains about 60 per cent of water of crystallization, so that after all the floor consists chiefly of solidified water.

**A NOVEL WHEELBARROW.**

The engraving represents an improvement in the class of wheelbarrows whose body is pivoted to adapt it to dump its contents by tilting or turning on its pivots. The improve-



KINCANNON'S IMPROVED WHEELBARROW.

ment consists in the extension of the front end of the frame beyond the wheel and body of the wheelbarrow, so that when the frame is suitably inclined its front end will rest on the ground, and together with the wheel, constitute a firm support for the pivoted body while being tilted.

This invention was recently patented by Messrs. J. and F. L. Kincannon, of Verona, Miss.