

AGRICULTURAL INVENTIONS.

Mr. Herman E. Wisner, of Howell, Mich., has invented a combined jointer and colter, constructed so that it may be attached to the plow beam with as much facility as an ordinary cutter, so that the edge of the furrow slice may be turned over, and the roots, vines, etc., cut off in front of the plow at the same time.

An improvement in grain-drills has been patented by Mr. Mads G. Madson, of Oslo, Wisconsin. The invention consists in combining with the feed wheel a seed cup having a hinged part provided with a recessed projection and lip, and in combining with a chain beam and pinion on the shaft beam a segmental ratchet lever fulcrumed on the side plate.

An improvement in sulky plows has been patented by Mr. William J. Meharry, of State Line, Indiana (Sheldon, Ill. P.O.). The object of this invention is to furnish an improved sulky attachment for plows which shall be simple in construction, may be readily attached to any ordinary plow, will materially lighten the draught, and will allow the plow to be readily controlled.

Ancient Petroleum.

Professor Skeat has printed in the *Athenæum* a passage from North's translation of "Plutarch's Lives" (1631, p. 702), from which it appears that petroleum was known in the time of Alexander the Great. The passage runs as follows: "For a Macedonian called Proxenus, that had charge of the kings carriage [baggage], as he digged in a certaine place by the riuer of Oxus, to set vp the kings tent and his lodging, he found a certain fat and oily veine, which after they had drawn out the first, there came out also another clearer, which differed nothing, neither in smell, tast, or savour from natural oile, having the glosse and fatness so like, as there could be discerned no difference between them: the which was so much the more to be wondered at, because in all that country there were no oliues."

Benzoate of Soda for Diphtheria.

Professor Klebs, of Prague, announces that the benzoate of soda is the best antiseptic in all infectious diseases. It acts, as the experiments of the author show, very powerfully. It is claimed that a daily dose of from 30 to 50 grammes to a full grown man will render the poison of diphtheria inoperative. The benzoate is prepared by dissolving crystallized benzoic acid in water, neutralizing at a slight heat with a solution of caustic soda, drying, and then allowing the solution to crystallize over sulphuric acid under a bell glass. Large doses do not appear to be absolutely necessary. Good results may be obtained by the daily administration of about 12 grammes.

NEW OPTOMETER.

The accompanying engraving represents an improved optometer recently patented by Messrs. E. G. Klein & J. X. Giering, of Rochester, N. Y. The instrument is designed to be used by opticians in ascertaining the limit of distinct vision, so that spectacles may be properly adapted to the eye. The device consists of a tube mounted adjustably on a standard, and having in one end a double convex lens, through which may be seen a translucent disk having a number of small dots printed on it. This disk is carried by a slide which is movable in the tube, and carries an index extending through a slot in the side tube and upward over a scale formed upon the upper surface of the tube. The graduations of this scale extend from a zero point toward A, for near-sighted tests, and from the same point toward B, for long-sighted tests. The number of the graduations correspond to the focal lengths of the different glasses, and when the dots on the disk are seen distinctly the index points to a number on the scale indicating the number of the glass adapted to the particular eye under test. The general appearance of the instrument is represented in Fig. 1, and the details of the lens and slide are shown in Fig. 2, which is a longitudinal section.

Sunlight in Norway.

At Christiana, at the summer solstice, the sun remains below the horizon only 5h. 17m.; at Trondhjem, 3h. 34m. At Bodø, the chief town in Nordland, the sun does not descend below the horizon from the 2d June till the 11th July; at Tromsø, from the 20th May to the 24th July; at Hammerfest, the chief town of Finmark, from the 15th May to the 29th July. On the other hand, the center of the sun does not appear above the horizon at Bodø from the 14th to the 28th December; at Tromsø, from the 25th November till the 16th January; and at Hammerfest, from the 20th November to the 21st January.

It is not surprising that barley, potatoes, and many other plants and vegetables ripen in the most northern latitudes, seeing they are exposed to a considerable amount of heat during two or three months of the year. In those regions where the sun hardly descends below the horizon in summer, there is no night, only a short twilight; the growing plant, therefore, enjoys permanently, and without interruption, the heat and light which it requires.

NEW ADJUSTABLE HOSE NOZZLE.

We give herewith an engraving of an improved adjustable hose nozzle recently patented by Mr. George C. Palmer, of Rochester, N. H. This is similar to a nozzle devised by the same inventor and described not long since in these columns;

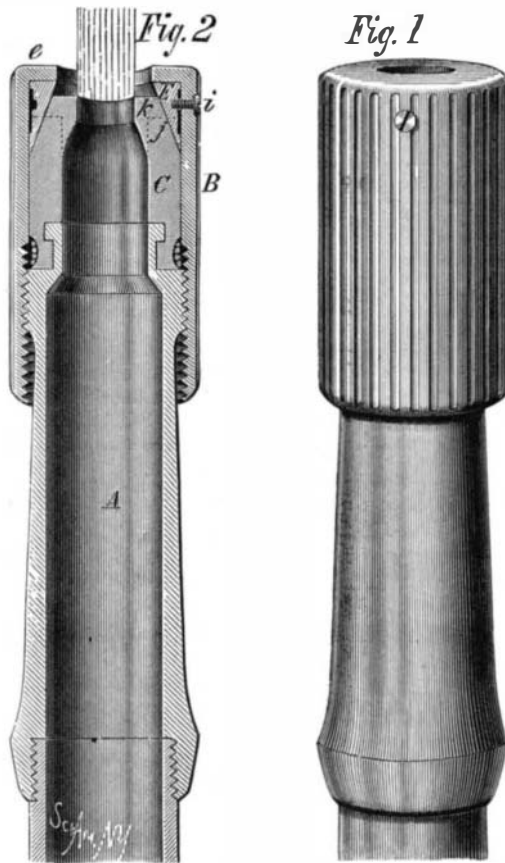

PALMER'S ADJUSTABLE HOSE NOZZLE.

but the present device is more perfect and better adapted to its work. Fig. 1 is a perspective view of the improved nozzle, and Fig. 2 is a longitudinal section showing the internal construction.

The tube, A, is threaded externally to receive the screw cap, B, and it is grooved around the end to receive the elastic bushing, C, which is secured to it by a wrapping of wire. The cap, B, contains a conical metallic washer, E, which is grooved circumferentially and held in place by a screw, i. The shape of the outer end of the rubber bushing before compression is shown at j in dotted lines, and the form it assumes when the conical washer, E, is forced down upon it is shown at k. The nozzle is easily adjusted to any re-

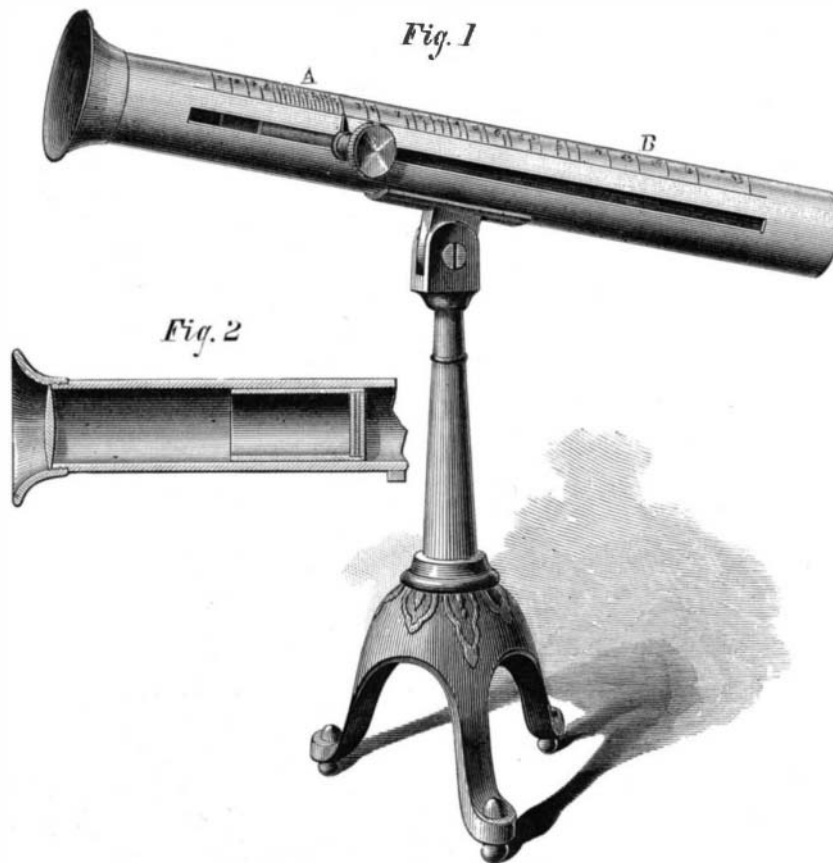

IMPROVED OPTOMETER.

quired size under high or low pressure, and it throws a smooth and uniform stream.

We are informed that this nozzle has been thoroughly tested by experienced firemen and pronounced a great improvement. It is found that a stream may readily be varied in size within wide limits, and that although the stream may be reduced in size very quickly, no sudden strain is thrown upon the hose to burst it, the operation of closing the flexible bushing being gradual.

For further information address Mr. George C. Palmer, P. O. Box 87, Rochester, N. H.

Arctic Navigation.

Prof. Nordenskjöld writes that, although unable to give a decided opinion at present, he thinks a voyage along the northern coast of Siberia, from the Atlantic to the Pacific Ocean, might often be performed by a steamer specially fitted out, and manned by an experienced crew; and that such a voyage would occupy only a few weeks. The condition of the Arctic Sea, so far as hitherto explored, would, however, deprive this route of any commercial value. He has no hesitation in affirming that the trade route from Europe to the Obi and Yenisei may be regularly adopted for commercial purposes. In all probability the route between the Yenisei and the Lena may be considered open to navigation; but a return voyage between Europe and the Lena could scarcely be accomplished in the course of summer. Prolonged explorations will still be necessary before the question as to the possibility of communication by means of sailing vessels between the mouths of the Lena and the Pacific Ocean is finally determined.

Starch Photo. Process.

In consequence of the remarkable results obtained by gelatine and silver bromide, experimentalists have been induced to try starch and gum emulsions, and the latest contribution to this branch of photography is a formula for a starch emulsion by Senors Paul and Ferran, of Barcelona. Take 4 grammes of potato starch and mix to a creamy consistency with 20 grammes of water; then add slowly 80 c.c. of boiling water, and, while the fluid is still hot, 1.12 grammes of bromide of potassium and 1.62 grammes of silver nitrate dissolved in 20 c.c. of water. It is recommended to add a little gelatine to the starch, in order to lessen the solubility.

MECHANICAL INVENTIONS.

Mr. Theodore E. Button, of Waterford, N. Y., has patented an improved feed-water regulator having a chamber of suitable size and shape located above the water line of the boiler, and connected with it by a pipe entering at the water line. This pipe must be large enough to allow steam and water to pass each other in it. The chamber may, however, be connected with the boiler by two pipes, one leading from the top of the chamber to the surface of the water in the boiler, and the other from the bottom of the chamber to any point in the boiler below the surface of the water. The chamber contains a float having a limited motion vertically, and connected with any device the motion of which will control the admission of water to the boiler.

An improvement in car axles, patented by Mr. Samuel D. Webster, of Cañon City, Col., consists in combining with the bearings, cap plates, oil cups, stop pins, and spring catches, the object being to prevent accidents from the breakage of axles.

Mr. Pedro Sanchez, of Tabasco, Mexico, has patented an improved machine for cleaning and extracting fibers. The main features of this invention are its springs, by which the concave chute is urged toward the revolving wheel, the stop screws, and the adjustable collar, by which this motion of the chute is limited.

Messrs. Edward L. Bartlett, of Olean, and Mowry O. Evans, of Portville, N. Y., have patented an improved log boring machine for boring logs for pumps and various other uses. It consists of a combination of mechanism that cannot be described without engravings.

An improvement in mining drills has been patented by Messrs. Charles F. Wilkinson, L. Sandidge Allison, Peter Riley, and Ario Mochamer, of Hazleton, Pa. This drill is especially adapted to the use of miners for prospecting, also to the use of coal miners.

Mr. Henry D. Sprague, of Providence, R. I., has patented an improved railroad switch, which is designed to prevent trains from running off the track through a misplaced switch. It consists of a combination of springs and the three pairs of switch rails and their connecting bars. The construction is such that a train from the main track will pass along the switch rails to either of two side tracks, according as the switch may be adjusted, and cannot get off the track, as the switch rails are always connected with one or the other of the tracks.

Mr. Ira Robbins, of Camden, N. J., has patented an improvement in the class of presses having a horizontally reciprocating platen, and is intended and adapted for printing cards. The blank cards are fed successively downward by pushers, which slide vertically in guideways, and are received by a device

combining the functions of tympan and platen, and are by it carried horizontally forward against the form to receive the impression, and then backward, and are discharged downward.

Mr. Angus McKellar, of Camp Douglas, near Salt Lake City, Utah Territory, has patented an improvement in vehicle wheel hubs. The object of the invention is to provide an improved vehicle wheel hub of the class in which the axle box is provided with a fixed radial flange, and the spoke tenons are confined between such flange and another which forms an integral part of a detachable sleeve that is screwed on or otherwise secured to the axle box.