

SCIENTIFIC AMERICAN

A WEEKLY JOURNAL OF PRACTICAL INFORMATION, ART, SCIENCE, MECHANICS, CHEMISTRY, AND MANUFACTURES.

Vol. XL.—No. 5.
[NEW SERIES.]

NEW YORK, FEBRUARY 1, 1879.

[\$3.20 per Annum.
[POSTAGE PREPAID.]

THE VOLTAIC PENCIL.

There is at the present time scarcely a single branch of industry to which electricity is not lending its aid. Art, however, has thus far received but little benefit from this source, if we except the application of electricity to electro-metallurgy. We are pleased to learn, then, that an important discovery has just been made at Paris by M. Bellet, whose invention consists of a voltaic pencil, by the use of which designers and draughtsmen will be enabled to dispense entirely with the aid of the engraver. The editors of *Electricité* state that they have examined beautiful proofs of lithographs and etchings obtained, without the use of the graver, by the effect of a voltaic arc produced at the point of an ordinary lead pencil. Encouraged by his success the inventor has taken out patents in various countries, and a company has been formed to carry out the process, which will soon be placed before the public. At present there are being prepared models of a series of apparatus which will allow any artist, however ignorant of the mysteries of electricity, to reproduce immediately, and without the aid of any artisan, the most delicate and complicated drawings; and this, too, by a very simple process and at a very moderate price. By a slight modification of the system there may be produced: (1) Stencils analogous to those produced by the Edison pen; (2) lithographs; (3) etchings; (4) stereotypes for typographical work. The initiators of this discovery are confident that an entire revolution will take place in the process of illustrating papers by means of their electrography.

ENGINE OF THE TORPEDO VESSEL DESTROYER.

The engine shown in the accompanying engraving was designed in 1878 by Captain Ericsson for his new torpedo vessel, *Destroyer*, an engraving of which appears on page 303 in the last volume of this journal. Both engine and vessel were built at the Delamater Iron Works.

The principal features of this engine are, that its base forms a surface condenser, 8 feet square, 24 inches deep, and that the cylinders, which are 24 inches diameter, 22 inches stroke, exhaust directly into the condenser. The cranks are placed at right angles, their journals being supported by pillow blocks bolted directly to the heads of the cylinders. The power of the pistons is conveyed to the connecting rod crosshead by four piston rods, two above and two below, equidistant from the center of the crank shaft.

It will be seen by reference to the engraving that the space between the ends of the valve and the crank shaft is so small that two valve stems become necessary.

The outer ends of these valve stems are connected by a vertical crosshead, to which the connecting rod of the reversing link is attached. It will be observed that the slide frames are unusually massive, the object being to obtain a firm support for the pillow blocks of two rock shafts provided with vertical vibrating levers, operated by the eccentric rods. The center of the reversing link being sustained by a pin inserted at the middle of the vibrating lever, it will be seen that the motion transmitted to the valve stems is twice that of the throw

of the eccentrics. It will be noticed that the eccentrics at the forward end of the crank shaft are very small, an advantage secured by bolting the same to the end of the shaft. The aft eccentrics, of course, are of the usual diameter. It may be mentioned that the steam valves are balanced by accurately fitted saddles of cast iron, under which they slide, effectually relieved from the heavy steam pressure (120 lbs. to the square inch) employed in these engines.

A NEW SWITCH PEDAL.

This novel device, which is the invention of Mr. C. A. Hussey, of 163 East 33d street, New York city, is designed



HUSSEY'S SWITCH PEDAL FOR CONTROLLING ELECTRIC MOTORS.

for controlling the electrical current employed in propelling small motors for driving sewing machines and other light machinery. A pedal is pivoted to the hollow base, and carries a spring that bears upon the block of insulating material at the toe of the base piece. This block is grooved transversely, and in the grooves are fitted three bars of metal, either of which may be touched by the contact spring as the pedal is pressed downward. The hollow base contains two

resistance coils and the wires which connect them with the binding posts seen on opposite sides of the base. This apparatus being connected with the electrical conducting wires of an electric motor, to start the motor, it is only necessary to depress the pedal so that the contact spring touches the first metal bar; the current then passes through both resistance coils and is thereby weakened. Should the power prove insufficient the pedal is further depressed so as to bring the spring into contact with the middle bar; this cuts out one of the coils and diminishes the resistance. By pressing down the pedal so that the spring touches the lower bar, the current passes directly, and its full power is realized; as the pedal is released the reverse of what has just been described occurs.

A Chance for Inventors.

There is a demand for a hand loom for amateurs' use. A correspondent writes: "We can get lathes and fret saws and printing presses and other machinery for the use of amateurs in abundance. But a compact, portable hand loom would be a novelty, of which it might with some truth be said that no house would be complete without it."

The number of people seeking industrial recreation is very large, and out of these a profitable clientele can be secured, no doubt, by whoever will offer them the novelty called for. It may pay some of our inventive readers to give the matter a little practical consideration.

New Mechanical Inventions.

Mr. John T. O'Harra, of Dodge City, Kansas, has patented an improved Car Coupling, which is so constructed that the cars will couple themselves when run together, and they may be uncoupled when standing still. The coupling may be operated from the top and sides or from the platform of a car.

An improved Hydraulic and Wire Rope Pumping System has been patented by Mr. William P. Barclay, of Virginia City, Nevada. The object of this invention is to provide apparatus for economically raising water from mines and deep shafts, and it consists in the arrangement of a hydraulic engine, with a series of plunger and other pumps, and a system of wire ropes and connections.

An improvement in Railway Cars has been patented by Mr. Louis Prince, of Nashville, Ohio. It consists in constructing the sides or panels of the car in sections so as to fold together, and in a window casing carrying a sliding sash adapted to swing inward.

Mr. Arthur C. Gould, of Boston, Mass., has devised an improved Street Sweeper, having an endless belt of brushes, operated by gearing from the axle of the machine, which belt sweeps the dirt upon an apron and carries it to a receptacle. The belt can be raised and sustained out of operation when that is desirable, and in use it adapts itself to the surface of the street.

Mr. William Loudon, of Superior, Neb., has devised an improved Double Acting Lift and Force Pump, which is so constructed as to throw a continuous stream of water by means of a peculiar arrangement of piston and valves.

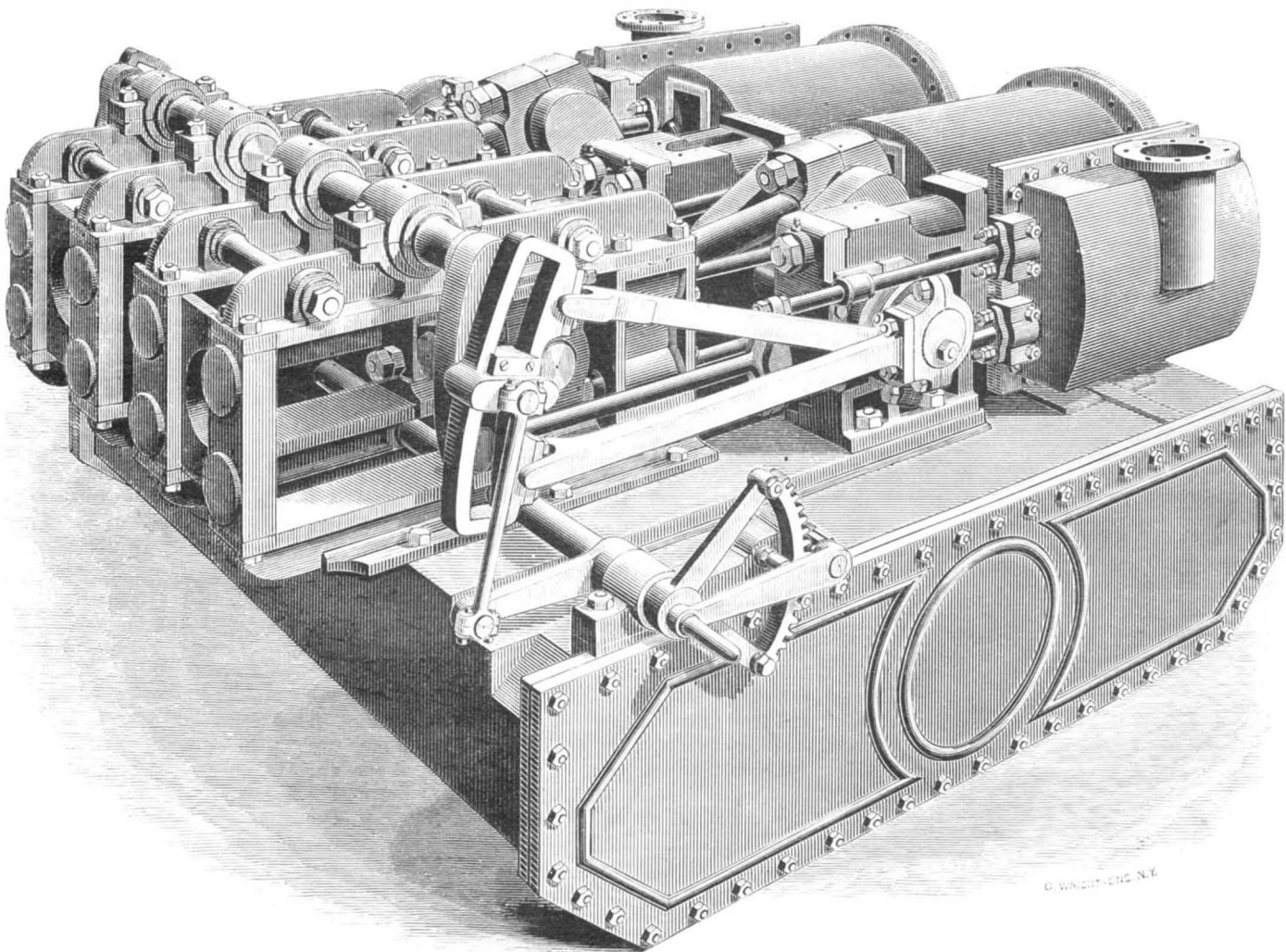

ENGINE OF CAPTAIN ERICSSON'S TORPEDO BOAT, "DESTROYER."

Scientific American.

ESTABLISHED 1845.

MUNN & CO., Editors and Proprietors.

PUBLISHED WEEKLY AT NO. 37 PARK ROW, NEW YORK.

O. D. MUNN. A. E. BEACH.

TERMS FOR THE SCIENTIFIC AMERICAN.

One copy, one year, postage included. \$3 20
One copy, six months, postage included 1 60

Clubs.—One extra copy of THE SCIENTIFIC AMERICAN will be supplied gratis for every club of five subscribers at \$5.20 each; additional copies at same proportionate rate. Postage prepaid.

Single copies of any desired number of the SUPPLEMENT sent to one address on receipt of 10 cents.

Remit by postal order. Address MUNN & CO., 37 Park Row, New York.

The Scientific American Supplement

is a distinct paper from THE SCIENTIFIC AMERICAN. THE SUPPLEMENT is issued weekly every number contains 16 octavo pages, with handsome cover uniform in size with SCIENTIFIC AMERICAN.

Combined Rates.—The SCIENTIFIC AMERICAN and SUPPLEMENT will be sent for one year, postage free, on receipt of seven dollars. Both papers to one address or different addresses.

Scientific American Export Edition.

The SCIENTIFIC AMERICAN Export Edition is a large and splendid periodical, issued once a month. Each number contains about one hundred large quarto pages, profusely illustrated.

The SCIENTIFIC AMERICAN Export Edition has a large guaranteed circulation in all commercial places throughout the world. Address MUNN & CO., 37 Park Row, New York.

VOL. XL., No. 5. [NEW SERIES.] Thirty-fourth Year.

NEW YORK, SATURDAY, FEBRUARY 1, 1879.

Contents.

(Illustrated articles are marked with an asterisk.)

Table listing various articles such as 'American Middlings Purifier Co.', 'Astronomical notes', 'Atmospheric air and the vacuum', etc., with corresponding page numbers.

TABLE OF CONTENTS OF

THE SCIENTIFIC AMERICAN SUPPLEMENT

No. 161,

For the Week ending February 1, 1879.

Price 10 cents. For sale by all newsdealers.

Table listing sections I through VII, including 'ENGINEERING AND MECHANICS', 'TECHNOLOGY', 'CHEMISTRY AND METALLURGY', 'ELECTRICITY, LIGHT, HEAT, ETC.', 'MEDICINE AND HYGIENE', 'AGRICULTURE, HORTICULTURE, ETC.', and 'MISCELLANEOUS'.

SOME PATENTS THAT SECTION 11 WOULD HAVE KILLED.

The object of Section Eleven is to make void certain patents described as undeveloped and useless, yet involving principles or devices which subsequent experimenters may want to use.

It is argued that if an invention has any real merit its profitable development will speedily follow, as a matter of course; in which case the additional fees will be no serious burden.

The fallacies which underlie this specious argument have been repeatedly exposed in these columns and elsewhere. We do not propose to discuss them here.

In 1833 Obed Hussey patented an invention which solved the problem of the harvesting machine. For many years he labored almost in vain to advance his invention to the stage of practical and profitable usefulness.

The real value of the Goodyear rubber patent will not be questioned at this late day. Taking up the struggle under which Heywood had succumbed, Goodyear toiled through years of terrible privation to perfect his invention.

The Sarven carriage wheel is known the world over. Section Eleven would have killed the patent on it most certainly and effectively. During the first eight or ten years of the life of the patent the inventor's efforts to induce carriage makers to adopt his improvement were almost fruitless.

The struggles of Woodworth alone, and afterward with his partner Strong, to persuade men to adopt his method of finishing boards by machinery, up to the time of his death in poverty in the eleventh year of his patent, would make a volume.

Another radical and immensely valuable invention was Henry Voelter's process of making paper-pulp from wood. The best years of the inventor's life were given to the development and introduction of the improvement, and in combating the prejudice of the trade to the use of wood pulp in paper.

Daniel Lamson invented a machine for notching hoops. It was not a great invention, yet it was novel and unquestionably valuable. He was a poor man; and before he had succeeded in introducing his invention he enlisted in a Massachusetts regiment and was killed at Fredericksburg.

It is needless to multiply cases. From the history of inventors and inventions in this country hundreds of similar instances might be drawn. In a very able paper lately read before the Cincinnati Board of Trade, Mr. George H. Knight has furnished a long list of them—instances of patient, persistent, and long protracted struggles against poverty and class prejudice, to bring valuable inventions up to the point of profitable and established usefulness.

Mr. J. Hasbrouck writes to the Bee Keeper's Magazine that his attention was lately called to some fine looking comb honey sold by a grocer in Williamsburg. He bought some of it at twenty-five cents a pound. It was very white, put up in the neatest possible box, and was altogether the finest looking honey he had seen this season.

GLUCOSE HONEY.

For a long time strained honey has been so largely adulterated with glucose, that intelligent buyers are very shy of honey in that state. Honey in the comb, however, especially if the comb is clean and white, disarms suspicion, though it is well known that respectable grocers are accustomed to surround comb honey in jars with clear honey mixed with a small percentage of glucose.

Mr. J. Hasbrouck writes to the Bee Keeper's Magazine that his attention was lately called to some fine looking comb honey sold by a grocer in Williamsburg. He bought some of it at twenty-five cents a pound.

This is carrying the matter altogether too far. It is well enough to manufacture honey comb for saving the labor of bees, so long as the bees are allowed to furnish the filling; and there may be no vital objection even to the selling of paraffin cells filled with glucose as a cheap substitute for the industrial product of bees, if any one wishes to eat it.

It appears, according to one of our French exchanges, that from the grains of raw coffee there may be extracted a beautiful green coloring matter adapted to all the purposes of the cook and confectioner, and which will undoubtedly prove of great value as a commercial product.

A VEGETABLE GREEN FOR CONFECTIONERS.

It appears, according to one of our French exchanges, that from the grains of raw coffee there may be extracted a beautiful green coloring matter adapted to all the purposes of the cook and confectioner, and which will undoubtedly prove of great value as a commercial product, inasmuch as the number of green colors suitable for such uses, and which are not poisonous, is very limited.

A NEW INDUSTRY.

For a number of years a Boston firm, emulous of the success which has attended the canning of baked beans, has been trying to discover a method for preserving the freshness and flavor of that other essentially Boston product, the codfish ball. They have at last succeeded, the Boston Advertiser reports, and the rapid demand for the article the world over seems to prove either a wide dispersion of New Englanders or else a widespread need of such an addition to the world's kitchen supplies.

The fish are killed by being stuck in the neck, and are hung up until every drop of blood is removed, and the napes are carefully scraped and cleaned. When salted and dried the fish are equal to the best Phillips' Beach fish. Nova Scotia potatoes are used, and instead of pork fat, the best Vermont and New York butter is contracted for at the dairy.

Since the 1st of September 20,000 bushels of potatoes have been used, and the codfish comprises several hundred quintals. The goods are shipped by the carload to Chicago St. Louis, San Francisco, Pittsburg, and other Western points. A case of the goods was on exhibition at the Paris Exhibition, for which a medal was awarded, and orders have been filled for France, England, Scotland, South America, Turkey, and China.

THE LAUNDRIES OF NEW YORK.

The manager of one of the larger laundries of New York lately said that there were between five and six hundred important laundries in the city, counting steam laundries that do the work of large manufacturers of white goods and of hotels and restaurants, and the hand laundries doing household work. The first steam laundry was started in Boston, in 1853. Several steam laundries in New York employ from 100 to 150 hands. The Empire Laundry, doing the work of fifteen hotels and restaurants, turns out 40,000 pieces a day, or more than 1,000,000 a month, washed, dried and finished. These pieces include sheets, pillow cases, white towels, silver towels, brown towels, brown table cloths, white table cloths, napkins, curtains, jackets, aprons, counterpanes, blankets, bed covers, pillow covers, chair covers, table covers, crumb cloths, and doilies. In the performance of this work there are used \$4,000 worth of soap, \$1,000 worth of starch, \$250 worth of bluing a year, and the pay roll amounts to \$25,000 yearly.

Another laundry manager said that the amount of private washing done in the public laundries has increased immensely since the establishment of the first large public laundry, the New York, at Bergen, N. J., in 1866. The largest are the St Denis, California, Home, Stuyvesant, and New York. The work they do is mainly for persons living in flats, boarders, bachelors, and transient hotel guests. Notwithstanding the great facilities offered by the public laundries, most housekeepers prefer to have their washing done at home. The public laundries that do private washing do not use steam or any machinery except the simple "patent wringer" and "housewife's washboard," because no machinery ever invented could do the necessary fluting, puffing, scalloping, and doing up. The charges range from 75 cents to \$9 a dozen.

The laundry business requires very little capital; the work is simple and the terms are invariably cash. No class of business men lose so little money from bad debts as the laundry men, and the reason is plain; they always have ample security for their bills in the clothing that they wash, and clothing is never returned until the bill is paid.

It is estimated that from one and a half to five million dollars are invested in laundries in New York, giving employment to from ten to twenty thousand persons.

HAECKEL ON EVOLUTION.

In his reply to Professor Virchow's charge that the evolution theory is as yet a matter of opinion, not a demonstrated position in science, Professor Haeckel takes occasion to state very forcibly the nature and scope of the theory of descent and the broad ground of fact on which it rests.

However complex in its details, the great problem of organic derivation is essentially simple. Species must have come into existence in one of two ways—by natural development or by supernatural creation. There is no third way. On the one side is the old theory that organisms were created specifically distinct, as they are, as they were, as they ever must be, independent in origin and permanent in form and character. On the other hand stands the theory that the different species of organisms are intimately related, have developed naturally from earlier forms, have descended from common ancestral types. On which side lies the weight of evidence? At starting, Professor Haeckel concisely defines the relation of the three great theories of modern biology: 1. Monism, the universal theory of evolution, or the monistic progenesis theory, is the only scientific theory, which rationally explains the universe and satisfies the desire for causality in the human mind, since it brings all natural phenomena into a mechanical causal connection as parts of a great and uniform (*einheitlich*) process of development; 2. Transformism, or the theory of descent, is an essential and indispensable part of the monistic evolution theory, because it is the only scientific theory which explains the origin of organic species in a rational manner, namely, by transformation, and reduces this transformation to mechanical causes; 3. The theory of selection, or Darwinism, is up to the present the most important one among the different theories, which try to explain the transformation of species by mechanical causes; but it is by no means the only one. Even if we suppose that most species have originated through natural selection, yet we know, on the other hand, that many forms called species are merely hybrids from two different species and are propagated as such; at the same time we can easily conceive that other causes may be acting in the formation of species, causes of which we have no idea at present. To decide what importance natural selection has in the origin of species is left to the judgment of the various naturalists, and in this question the authorities differ materially even to-day. Some ascribe a greater, others a smaller importance to it. But the different estimation of the value of Darwinism is quite independent of the absolute validity of the theory of descent, because the latter is up to the present the only theory which explains, in a rational way, the origin of species.

The theory of creation explains nothing, and is inconsis-

tent with a vast multitude of demonstrated facts and laws. The scientific certainty of the theory of descent, on the contrary is based upon the totality of biological phenomena. Professor Haeckel shows that all phenomena of morphology and physiology, of chorology and oecology, of ontogeny and palæontology, can only be explained by the theory of descent, and reduced to mechanical causes. The guarantee of the truth of the theory lies particularly in the fact that the last simple causes are the same for all these complicated phenomena, and that other mechanical causes cannot be imagined. If further proofs are demanded, where are they to be looked for? In Professor Haeckel's words, "where in the world are we to find 'facts' which speak louder than the facts of comparative morphology and physiology, the facts of rudimentary organs and of embryonal development, than the facts of palæontology and of the geographical distribution of organisms—in short, than all the known facts from the most various biological domains?"

If the theory of evolution is not amply proved by the facts already in possession, then, Professor Haeckel asserts, the theory never will be proved.

A GREAT MARKET FOR OUR CATTLE AND OTHER PRODUCE.

Under rules lately adopted by the British Government, which went into effect on New Year's Day, the United States will have the advantage over many other countries in landing cattle in the United Kingdom, as from Russia, Austro-Hungary, Turkey, Greece, Italy, and Roumania live cattle cannot be landed, and from Germany, Holland, Belgium, and France cattle can only be landed at six ports, under strict inspection, to be slaughtered within ten days of their arrival; but cattle from Denmark, Sweden, Norway, Spain, Portugal, and the United States are exempt from compulsory slaughter or quarantine.

The immediate effect of these rules will be to confine the large supply of cattle required by England to a few purveyors, among which the United States is much the largest producer, as the severity of the regulations will practically prevent the nations in the second list from engaging actively in the live cattle trade, and those in the last list, with the exception of Canada, have comparatively few cattle to export.

More than 60 per cent of the people of Great Britain are dependent on foreign food supplies, while her steadily growing population is increasing this dependence every year.

The numbers of live animals imported into the United Kingdom during the year 1877 were about 300,000 cattle, 1,000,000 sheep, from 40,000 to 50,000 swine, 30,524 horses, and the imports of last year are believed to largely exceed those numbers. Since the 1st of last May and up to the 1st of September there have been an average of 3,000 cattle a week shipped to Great Britain from Montreal, Boston, New York, Philadelphia, and Baltimore. This trade, however, is in its infancy as yet, and will, without doubt, grow immensely before long, when the best methods of shipping have been devised and the prejudices against American meat been overcome. With the immense quantity of cheap grazing lands we have we can defy competition to other countries in raising cattle.

Returns of British grain imports from the various countries for a period of nine months ending October 31, 1878, show:

From.	Cwts.
Russia.....	7,432,443
Germany.....	4,112,184
France.....	11,061
Turkey, Wallachia, and Moldavia.....	200,857
Egypt.....	193,194
United States (on Atlantic).....	20,903,997
" " (on Pacific).....	4,208,942
Chili.....	49,994
British India.....	1,577,342
Australia.....	1,309,559
British North America.....	1,968,244
Other countries.....	214,285
Total.....	42,182,102

From this it will be seen that the total quantity received from the United States was 25,112,939 cwts., or 59½ per cent of the total importations.

The annual importation of food into Great Britain is about \$800,000,000 worth, of which a large proportion will be drawn from this country if we pay proper attention to the business. To make the most of this grand market every facility should be given to shippers by cheapening freights, lessening the amount of handling or transferring from cars to vessels, or *vice versa*, and increasing our inland water transportation facilities, as the difference of a cent or two per bushel in the cost of freighting or handling grain may largely influence the trade in that article and make all the difference between a very profitable business and a losing one.

A HINT FOR AN INVENTION.

We call the attention of inventive and practical men to the defects of locomotive boilers, and the advantages which would result from their improvement.

A locomotive boiler has three principal parts, all imperfect in greater or less degree. These are the fire box, the tubes, and the smoke box. The fire box has rectangular walls, surrounded by water, except under the grate, and where the fire door is placed. This is an arrangement necessitated by the requirements of science and not indicated by rules of utility

or good construction. The flat form of the fire box walls and of that part of the boiler which covers it, takes away from them strength of resistance, save what is given to each by the other by stays in immense number. These must resist an enormous pressure, especially the roof of the fire box, where it is not counteracted by any opposite pressure, and sometimes may amount to 200 tons.

This arrangement prevents proper cleaning of the outer walls of the fire box and the inner walls of the boiler plates opposite. It is about the same thing where the tubes are; and these, rarely over 2½ inches in diameter, are so numerous that it is as difficult to clean them exteriorly as it is to clean that portion of the boiler surrounding them.

The draught, urged by the jets of exhaust steam in the stack, is so strong that the air and gases in passing through the tubes at a high rate of speed drive with it a considerable quantity of fine dust, the residue of combustion of coke or other fuel; this dust scratches and cuts the tubes so as to necessitate their renewal. The dilatation and contraction of these tubes also cause leaks and repairs. The forced draught also costs dear in another way; because this steam jet creates a back pressure in the cylinders, frequently amounting to one third the effective pressure. Further, the space left above the tubes and the smoke box is so small as to reduce too much the proportion between the steam volume and the heating surface. It is also not unfrequent that the steam carries with it half its weight of water.

Ancient Letters in Modern Tattooing.

At a recent meeting of the British Anthropological Institute Mr. Park Harrison read a paper on some characters which are still in use as tattoo marks by the Motu, a people located in the southeastern peninsula of New Guinea, and described by the Rev. Dr. Turner as a race superior to the Papuans, from whom they differ both in color and customs. About half of the more distinctive forms tattooed on a Motu girl, carefully copied by Dr. Turner, correspond with letters in the Asoka inscriptions in India, which are believed to be allied to Phœnician, while several others resemble letters admittedly derived from the same stock, but independently acquired. The marks are mostly arranged in groups of three; on the right arm, however, nine or ten are apparently connected by a line running above them all. The characters are twenty-three in number, and are formed of straight lines in the following combinations, viz.: five of 2 lines, nine of 3 lines, five of 4 lines, and three of 5 lines, much in the same proportion as in the Rejang and Lampong alphabets of Sumatra, the letters of the former of which have been shown to be identical with Phœnician characters reversed. Archaic forms of letters have also been met with in several islands of the Indian Archipelago and Melanesia, but are now without meaning. The Motu characters are used simply for ornament or as charms. As an example of the use of letters for tattoo marks, the case of the Austrian subject was cited, who, having been taken prisoner in Burmah, a few years ago, was there tattooed with letters and other patterns. Besides the characters on the Motu girl, there were various pictures, or hieroglyphics, consisting of eyes and eyebrows, a lunar crescent, and other forms.

How Diphtheria was Spread.

A few weeks ago a little girl in St. Albans, who had just recovered from diphtheria, was taken by her parents to visit a family in a neighboring town. She slept with the children in that family, and shortly afterward three or four of them were taken with the malady, and some have since died. The family permitted relatives and neighbors to visit them, and the result is several cases in the neighborhood. They had public funerals, even keeping the remains of one child an unusual time, waiting for another to die, so as to bury them together; and this also spread the contagion. The physician was not powerfully impressed—as some physicians are not—with the contagious character of the disease; therefore, he did not take the necessary precautions for the protection of the neighborhood or of his own family, and the result is that one of his own children has died and another is dangerously ill. A lady who went to one of these houses to robe the victims for the grave has called at houses in the vicinity where there are children, without any change of her garments or any attempt at disinfection, and has fondled the children in those families, apparently in utter ignorance of the danger to which she was exposing them.—*St. Albans (Vt.) Messenger.*

Women Inventors.

The question is often asked us: Do the inventions of women ever amount to anything? From our long experience with inventors of both sexes, we conclude that a larger proportion of inventions patented by women prove useful and profitable than those of the sterner sex. We see by the *New York Sun* that the Metropolitan Elevated Railway Company has selected a device, from the many that have been under consideration, for lessening the noise of the trains, and that it is the invention of a Mrs. Walton, of this city. The plan consists of boxing the rails in a mixture of sand, tar, and cotton, and has been under test for two months on several blocks of the road in Sixth avenue. The ringing of the wheels on the rails, which makes a large part of the objectionable sound, is considerably deadened. She gets, according to the *Sun*, \$10,000 for the use of the invention on the Metropolitan line, and the company is to control its adoption on other roads, paying her a royalty.

THE DEMENGE ENGINE AND BOILER.

Our illustrations, which we take from *Revue Industrielle*, represent a compound steam engine and boiler, constructed by Mr. Demenge, and received with much favor in France. Fig. 1 shows a stationary engine. The steam enters the smaller high pressure cylinder first, expands partially and then passes into the larger cylinder, where the expansion is completed. Pressure is exerted only between the exterior head of the cylinder and the pistons, and not on the inner surfaces of the latter. The cylinder heads and the pistons are partially covered with lead, which, being a poor conductor of heat, diminishes condensation.

The connecting rods being subject to compression only, and acting in opposite directions on the shaft, may be made of cast iron, and the cranks may be smaller than in ordinary engines.

The velocity of this engine may be greater, and consequently a larger amount of work may be accomplished than by other engines of similar dimensions. The condenser pump has no exhaust valve, but its piston is connected with that of the low pressure cylinder in such a manner that it acts only during one quarter of the revolution, commencing just when the action of the piston of the large cylinder on the crank and shaft ceases. The cylinders and valves are so proportioned that the pressure on the pistons remains the same throughout the stroke, no matter what may be the degree of initial pressure and expansion in the high pressure cylinder. Tight joints placed at each side of the shaft prevent the air from entering the large cylinder.

The shaft is made of steel; the surface subject to friction is rather large, and is automatically lubricated.

The regulator does not act on the distributing mechanism directly, but operates on a separate valve. Fig. 2 shows the engine combined with a portable boiler, for agricultural purposes. Although rather clumsy and more complicated than desirable in agricultural machines, it is yet said to recommend itself by its economy in regard to fuel.

The boiler, of which Fig. 3 shows sectional views, is of the Thomas-Laurens type, and is placed in oblique position; this is done to prevent any water from being carried along with the steam and to facilitate the attachment of the tongue. Fig. 3 illustrates the position of the tubes, which are partly surrounded by water, partly by steam.

Chinese Dentistry.

It is well known that the Chinese attribute toothache to the gnawing of worms, and that their dentists profess to take these worms from decayed teeth. But how they performed this trick, and so artfully concealed it in the hurry of daily business, was a secret only recently solved by a European inquirer. After some difficulty and delicate negotiation, an intelligent looking native practitioner was induced to hand over the implements of his trade, together with a number of the worms, and to give instructions in the method of procedure. When a patient with toothache applies for relief, if the tooth is solidly fixed in the socket, the gum is separated from it with sharp instruments and made to bleed. During this operation the cheek is held on one side by a bamboo spatula, both ends of which are alike, and on the end held in the hand some minute worms are concealed under thin paper pasted to the spatula. When all is ready, this is adroitly turned and inserted in the mouth, and the paper becoming moistened is very easily torn with the sharp instrument used for cutting the gums; the worms mix with the saliva, and the dentist, of course, picks them out with a pair of forceps. The patient having ocular demonstration that the cause of the disease has been removed, has good reason to expect relief, which in many cases would naturally follow the bleeding of the gum. When the pain returns, the same operation is performed over again, and a fresh supply of worms fully accounts for the recurring trouble. These worms are manufactured in quantities to suit the trade, and they are very cleverly done; still, to carry out the delusion fully, the dentists are obliged to keep on hand a few live worms to show their patients, explaining that most of those taken from the tooth are killed either by a powder which is often applied, or by the process of removing them with the forceps. This is resorted to when the tooth is firmly set.—*Chambers' Journal*.

Telegraph Messages through Metallic Tubes.

When the plan of delivering messages through tubes from the main telegraph building in this city to the most important business marts was first adopted a description of the tubes and operation of the pneumatic arrangement was described in the *SCIENTIFIC AMERICAN*. More recently an ac-

Stock Exchange and the branch telegraph office there, and other pipes down to the Cotton Exchange and to the branch office near by there. These were pneumatic tubes, 2½ inches in diameter. They were four in number—two of them "up" tubes, as they are called, worked by exhausting the air and making a vacuum, and two of them "down" tubes, worked by pressure. The messages were rolled up thereafter and placed in little leather boxes, open at one end, and about 6 inches long, and shot back and forth between the main and branch offices, instead of being sent by messenger boys or telegraphed over the wires. The company is now exchanging from 3,000 to 4,000 and more messages a day, through their pneumatic tubes, between the main office on Broadway and the branch offices at and near the Stock and Cotton Exchanges. It saves thereby the labor of at least 25 telegraph operators, and the public is saved much expense.

The tubes are, two of them, 2,100 feet long (the Wall street tubes), and two are respectively 3,000 and 3,500 feet long. They are worked by a steam engine, which has a capacity of 75 horse power, but which is never called upon for half its resources. An engineer and four boys at the tubes are all the employees needed in place of the 25 skilled operators.

This system has worked so well in the business emanating in the commercial and financial quarters of the city, that it is to be extended to Printing House Square, connecting with the offices of the principal daily newspapers.

New Inventions.

An improved apparatus for use in photographic galleries as an accessory in forming backgrounds for pictures has been patented by Mr. William F. Ashe, of New York city. It is so constructed that it may be arranged as a staircase, a balustrade, or a pedestal, as may be required.

Mr. John A. Caldwell, of Brownsville, Tenn., has patented an improved Compound Beveling Instrument for the use of stair builders, carpenters, millwrights, and others, by which complicated cuts, such as the pitches of handrails and bevels of jack rafters, are easily obtained.

An improved Attachment to Stemwinder Watch Cases has been patented by Mr. Joseph Fortenbach, of Carlstadt, N. J. The invention consists in a perforated metallic plate fitted upon the winding stem and interposed between the lock spring and the center ring of the watch case, to operate the spring at one side of and out of contact with the stem.

Mr. Gilbert W. Bradley, of Sunderland, Vt., has patented an improved Wooden Box. The process consists in bending wooden veneers into tubular shape under successively decreasing arcs and increasing pressures, and sewing together the lapped edges.

Messrs. Hiram D. Jewett and Israel D. Jewett, of St. Omer, Ind., have patented an improved Mechanical Telephone, which is so constructed as to receive the full volume and force of the voice and other sounds, magnify them, and transmit them to the instrument at the other end of the line with distinctness, so that they can be clearly heard at considerable distance from the instrument.

Mr. Lawrence Klemm, of Terre Haute, Ind., has patented an improved Apparatus for Cleaning Middlings by means of a force and suction draught.

The device is of simple construction, and requires less power than the complicated machinery at present employed for separating the middlings from the lighter particles.

Mr. Marshall R. Dowlin, of North Adams, Mass., has patented an improved Attachment for Flexible Leather Covered Horse Collars of double harness, for the purpose of protecting the throat of or lower end of the collars from wear, and from being drawn or bent out of shape by the tension of the pole strap.

Mr. Wm. H. Hubbard, of Red Bank, N. J., has patented an improved Gate, which consists of metal or wooden bars supported at one end in a post having a friction roller at the bottom running on a rail, and at the opposite end entered into metal or wooden tubes placed in or constituting the adjoining panel of the fence, so that when the gate is opened the rods of which it is made slide or telescope into the tubes of the adjoining panel.

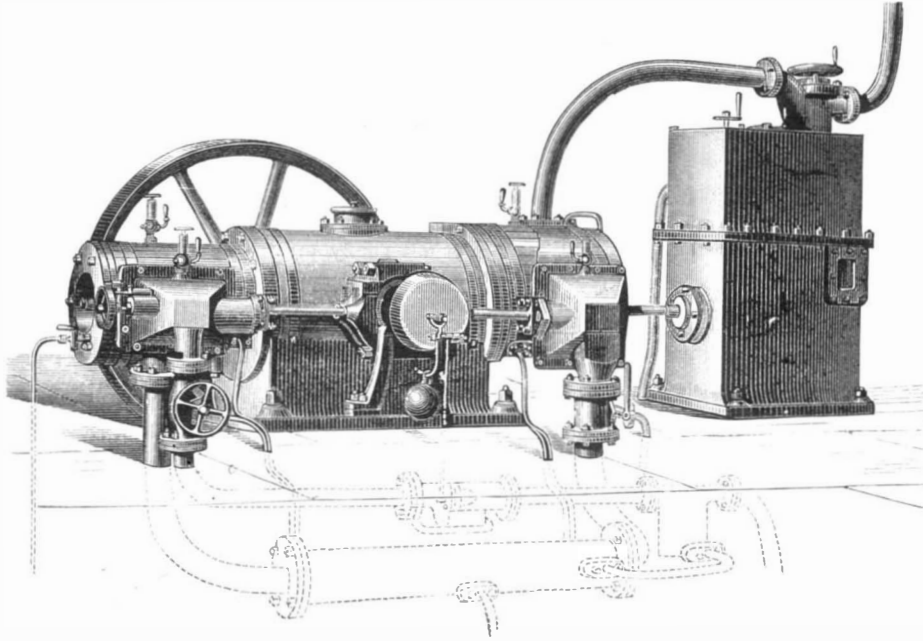
**Fig. 1.—STATIONARY DEMENGE ENGINE.**

count of the success of the enterprise has been published in the *Philadelphia Press*, from which we copy:

Great are the economies of machinery, commences the writer. Two years ago the Western Union Telegraph Company came to the conclusion that the business of getting

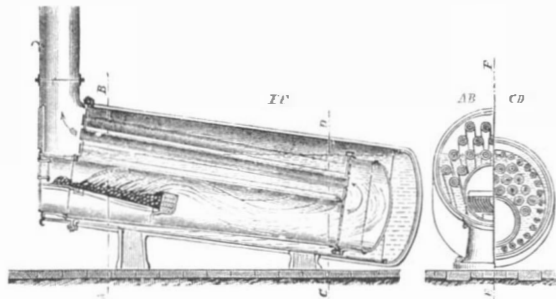
**Fig. 3.—THOMAS-LAURENS BOILER.**

messages from the main office on Broadway to Wall street and back was costing the company and the public more than necessary. In order to cheapen the expense of the large volume of business emanating in that part of the town, the company laid brass pipes, properly protected from the moisture, down Broadway and Wall and Broad streets to the

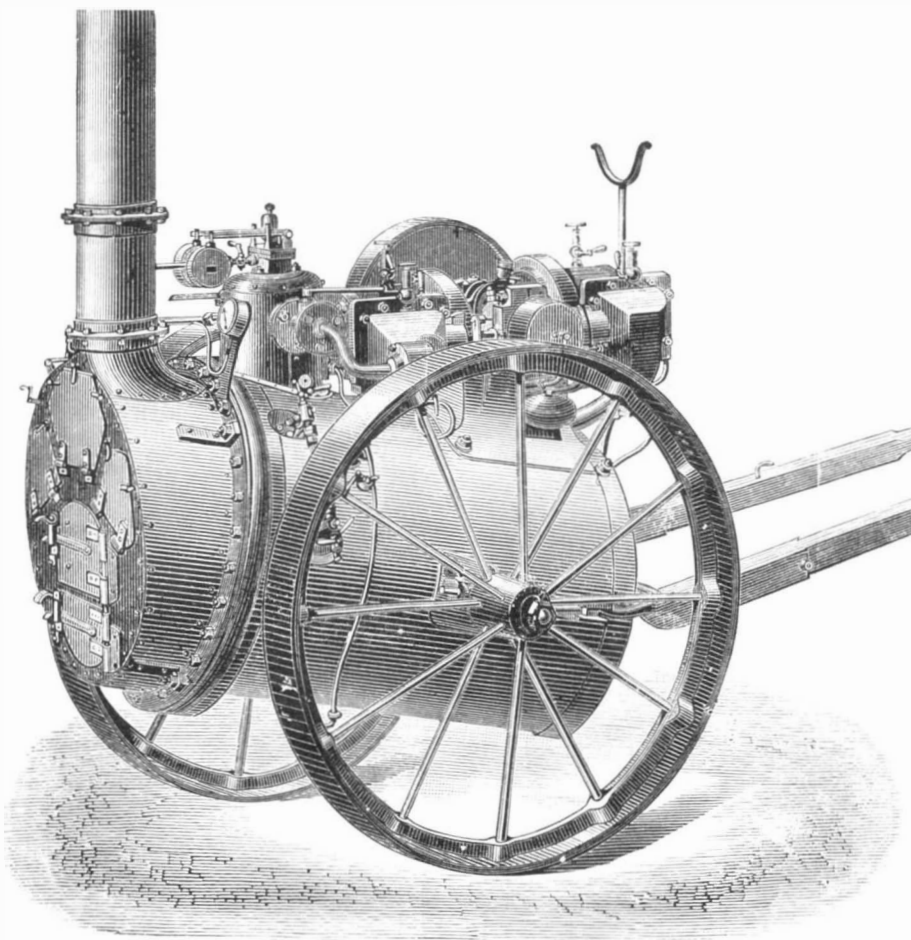
**Fig. 2.—PORTABLE DEMENGE ENGINE.**

A NEW POTATO DIGGER.

We illustrate herewith a novel potato digger recently patented by Mr. H. Strait, of No. 18 Sixth St., Troy, N. Y. Its new features will be readily seen by reference to the engraving. The plow, A, which runs under the potato hills, has a vertical standard that runs upward through a guide in the frame, and is connected by links with the lever, B, which is fulcrumed on the tongue. The free end of this lever passes through a slide that carries a spring latch, and is movable on a vertical standard, C, that is supported by the machine frame. Behind the plow, A, there is a toothed cylinder, D, that is journaled in two arms, E, pivoted to opposite sides of the frame. The cylinder, D, as well as its teeth, are of hard wood. The ends of the cylinder shaft carry pinions that are engaged by internally toothed flanges on the inner faces of the drive wheels. The upper ends of the arms, E, are pivoted to a fork having two mortises, either of which may be placed over the standard, G. By means of this fork the pinions of the tooth cylinder are thrown into and out of gear. Behind the toothed cylinder there is a series of curved tines, H, which alternate in position with the teeth of the cylinder, D.

As the machine is drawn forward the earth is loosened by the plow, and the potatoes are separated from it by the revolving toothed cylinder. The tines, H, prevent the vines from winding on the cylinder, and also prevent the potatoes from being thrown upward by the teeth. It is claimed by the inventor that the machine is very effective in its operation.

For further information address the inventor as above.

THE MANUFACTURE OF LARD.

American refined lard, as an article of export, will overreach the round sum of \$30,000,000 per annum, ranking the sixth in value out of \$600,000,000 of American exports. It is exceeded only by cotton, breadstuffs, petroleum, tobacco, and bacon.

The American lard of the brand of "W. J. Wilcox & Co.," made in New York city, has received the gold medal at the Paris Exhibition for its excellence, being the only gold medal awarded for lard. It was given for uniformity of color and body, sweetness, and superiority of preparation for exportation. The annexed engraving represents the lard exhibit of W. J. Wilcox & Co. at the Paris Exhibition.

At the Centennial Exhibition the company received the highest award and prize medals for the purity of their various productions.

It is said that the Wilcox lard forms about one half of the entire shipment of that commodity from New York; and of the nearly one and a half million tierces annually exported from the United States, two thirds of the total amount go from the metropolis. This immense foreign demand gradually increases every year, and the domestic consumption constantly grows larger.

Though still doing business under the original firm name of W. J. Wilcox & Co., the concern has, for several years, been an incorporated company, with the following officers: Mr. William A. Cole, President; Mr. Samuel E. Hiscox, Vice-President; Mr. E. T. Bell, Treasurer. The entire stock is owned by these gentlemen, who are virtually in copartnership.

The refinery of this concern is very extensive, covering a large area of the block bounded by Greenwich, Washington, and Vestry streets. There are also extensive premises in West Twelfth street. Altogether there are about three hundred workmen employed. The works are completely provided with the most approved modern machinery, of which the company are the inventors and owners.

The crude material, which is constantly arriving, is most rigidly inspected, and any portion of it that fails to meet the required standard of taste, color, and consistency, is promptly condemned and removed. The approved stock is then emptied into enormous kettles, some of which have a capacity of 75,000 lbs. The kettles being filled, sufficient heat is applied until the mass is thoroughly cooked, after which

it is transferred to coolers. At this stage of the process certain methods peculiar to the Wilcox Company are applied, which render the lard white, sweet, pure, and uniform in texture and quality. The next process is to run it through the pipes into huge tanks placed in the sub-cellars. Thence it is drawn off in vessels varying from a 1 lb. tin can to a 320 lb. wooden tierce. All these packages, when filled, are carefully cleaned from all outside drip; they are then weighed

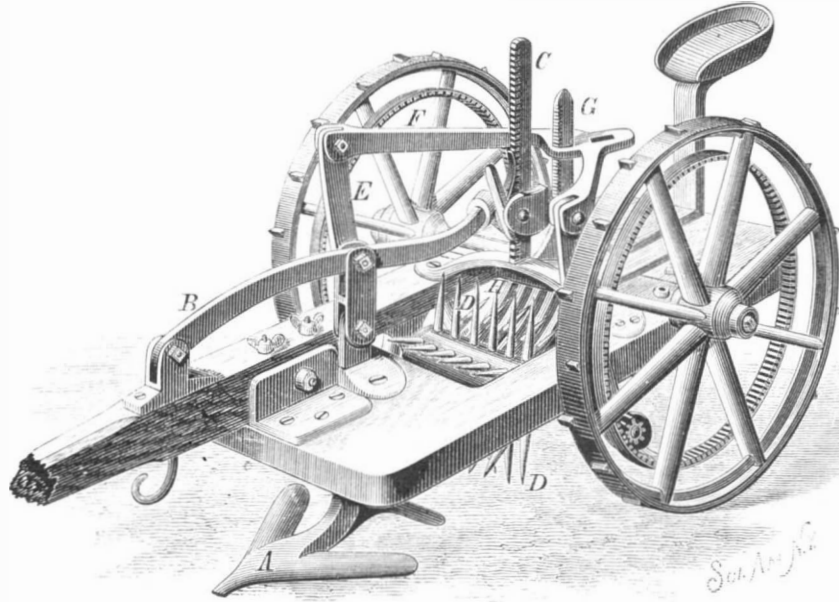

STRAIT'S POTATO DIGGER.

and branded—the smaller sizes being packed in cases. It is stated that there is not a country in the world to which the refined lard of Wilcox & Co. does not go; there is not a commercial city in continental Europe in which its price is not specifically quoted each day, to the exclusion of all other productions; and the manufacturers assert there is not an instance known of a shipment having been defective in quality, short in weight, or in any degree of perfection below the standard.

The offices of the concern are located at 41 Broad street, New York city, and are in telegraphic communication with the works. A wire connecting with the Western Union Telegraph Company's main office delivers domestic telegraph advices, and cable news from all parts of Europe.

Superb Photographs.

We are indebted to F. Gutekunst, the well known photographer in Philadelphia, for copies of excellent photographs

Preservation of Butter.
The Italian Minister of Agriculture, Industry, and Commerce has addressed a communication to the Chamber of Commerce of Milan relative to the renewed experiments in salting butter with borax which have been carried out at the Agricultural Station at Florence. From the account which appears in our contemporary, the *Giornale di Agricoltura*, borax would appear, says the *London Grocer*, to have a most marvelous effect in insuring its absolute preservation. Samples of fresh butter made at the Florence station, and purposely not carefully freed of their buttermilk, were found, on the addition of about 8 per cent. of borax, to maintain their natural fine flavor without the least change whatever for upwards of three months. To attain this satisfactory result it is necessary that the borax should be perfectly dry and in very fine powder, and care must be taken to insure its thorough mixture with the whole mass of the butter operated on. Among the further advantages of this plan, it is noted that borax imparts no flavor of any kind to the butter, while it is entirely harmless in its nature, and also reasonably cheap. Still later experiments have shown that a very much smaller proportion of borax suffices to produce the desired effect, and, also, that simple solutions of the salt act quite as well as the dried powder.

[We cannot recommend our agriculturists to enter largely into the substitution of borax for salt in butter for house use, but it may be well for some to try the experiment on a small scale.

The consumers on the Continent are averse to salted butter, and likely they may prefer borax as a preservative, while our people will adhere to their salt.—ED.]

To Render Wood Incombustible and Impermeable.

According to the *Timber Trade Journal*, M. M. P. Folbacci claims to give these properties to wood by means of the process described below. It thus becomes petrified, so to speak, without, however, undergoing any change of appearance. On being subjected to intense heat it becomes charred on the surface, but very slowly and without any flame, and it is only necessary to scratch the surface to find the substance of the wood intact. Hence in case of fire, the firemen would have no occasion to fear that the materials on which they tread would give way beneath them, if this operation has been undergone by the wood composing staircases, floors, etc.

The following chemical compound is said to produce the result: Sulphate of zinc, 55 pounds; American potash, 22 pounds; American alum, 44 pounds; oxide of manganese, 22 pounds; sulphuric acid of 60°, 22 pounds; water, 55 pounds. All of the solids are to be poured into an iron boiler containing the water at a temperature of 45° C., or 113° F. As soon as the substances are dissolved the sulphuric acid is to be poured in little by little, until all the substances are completely saturated. For the preparation of the wood it should be placed in a suitable apparatus, and arranged in various sizes (according to the purposes for which it is intended) on iron gratings, care being taken that there is a space of about half an inch between every two pieces of wood. The chemical compound is then pumped into the apparatus, and as soon as the vacant spaces are filled up it is boiled for three hours. The wood is then taken out and laid on a wooden grating in the open air, to be rendered solid, after which it is fit for uses of all kinds, as ship building, house building, railway carriages and trucks, fence posts, wood paving, in short, for any

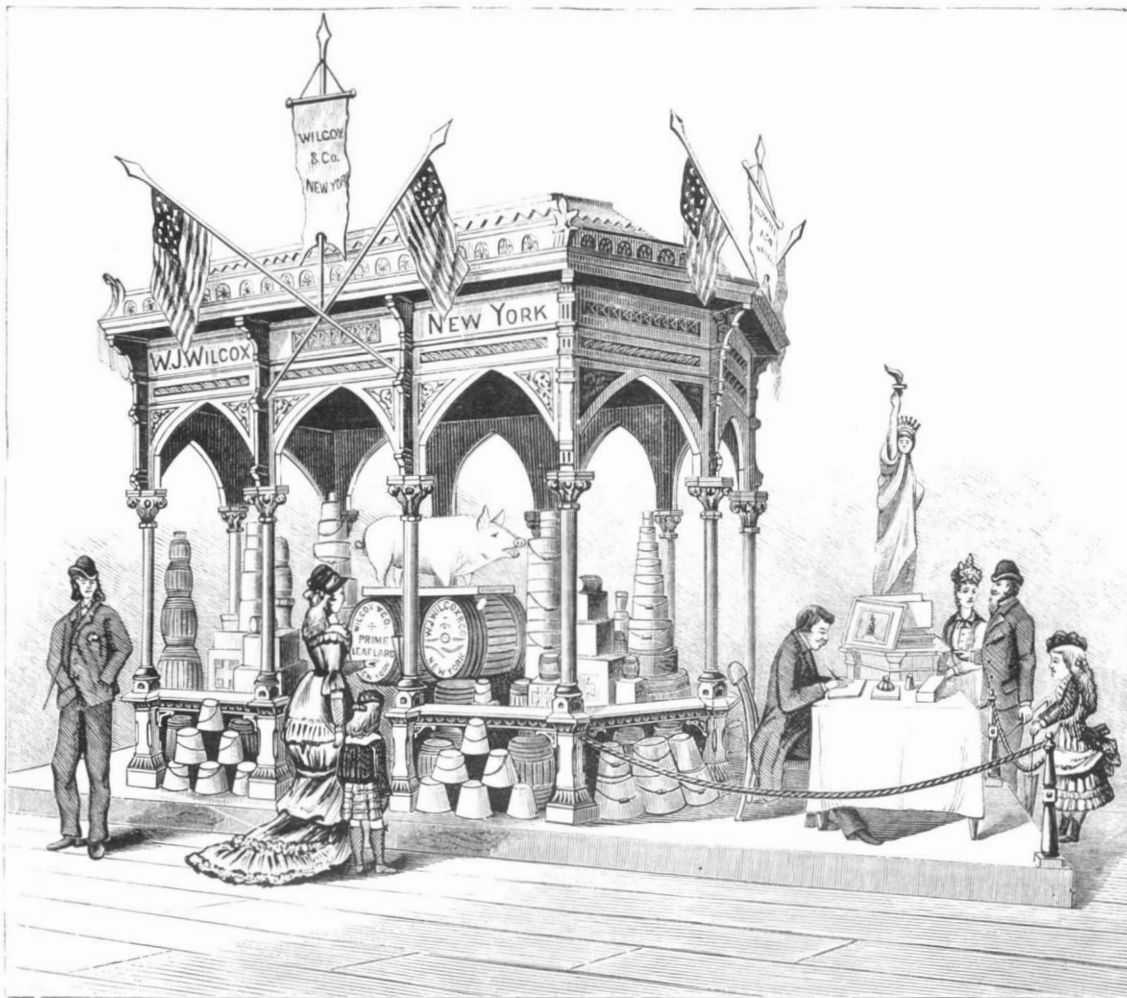

W. J. WILCOX & COMPANY'S EXHIBIT AT THE PARIS EXHIBITION.

of the late Bayard Taylor and Morton McMichael. The former was the American Minister to Berlin, and the latter, the proprietor and editor of the *North American* Newspaper.

The shipment of American oysters to England is now carried on to the extent of from 1,200 to 1,500 barrels a day. On December 7 nearly 2,600 barrels were shipped for the Christmas trade.

kind of work where there is any liability to destruction by fire.

Mining Notes.

As mining investments continue to attract increasing attention in the East, New York is becoming the great mining exchange of the country, where the idle capital of the East, seeking investment, and the mineral riches of the West and South seeking development, meet to build up enterprises that

in the aggregate promise in a few years to add more to the wealth of the country and give more profitable employment to labor than any other one industry now pursued here.

There is scarcely a good mining property that is not now represented in New York, and there is hardly a newly discovered mine east of the Pacific coast range that does not seek for capital here.

It is unavoidable that some purely speculative enterprises should be offered side by side with legitimate ones, that some swindling operations should be successful; but the means are daily multiplying, the system is daily improving, whereby it will be possible to give to each its rightful rank, so that proposing investors may make their choice.

Southern gold mines are now attracting much attention, and it is reported that eleven of the North Carolina and Georgia gold mines were sold to New York parties a week or two since, and that contracts are being negotiated for many of the best mining properties in these sections.

From the Eagle Gold Mining Co., Stafford county, Virginia, comes a report that the vein is from 14 inches to 6½ feet thick, and that the shaft has been sunk 160 feet. Before the war it is said the mine yielded 13 ounces of gold for every \$25 paid for wages; now it yields 16 ounces for the same outlay. The Findley Mine, Georgia, has just paid a small dividend, and expects to pay another this month, from surplus earnings. A number of individual enterprises in the South are reported as doing well on the capital invested.

The profitable development of the majority of the Southern mines would have been impossible a few years ago; improved machinery and processes and mining knowledge gained by costly experience have, however, made these and many poorer properties present good investments.

The Homestake Mine, of Dakota, covering 1,350 feet by 450 feet on the mineral vein, has ordered 120 stamps for spring work in addition to the 80 now in operation. The present gross production of the company is about \$60,000 per month, and regular dividends seem to be assured for a long time to come.

The silver production of Leadville, Colorado, exceeds all expectations, and new discoveries are daily reported. The product of the leading mines has increased 50 per cent within the past few weeks. Two thousand tons, yielding 20,000 ounces of silver, were delivered last week, and 3,000 tons of high grade were awaiting transportation. It is estimated that the product of the camp for the year 1878 will reach \$3,000,000.

In Idaho placer mining on the Snake, Boise, and Fayette rivers and their tributaries is being vigorously resumed, because of recent improvements in processes for securing the fine gold, and most satisfactory results are anticipated. The working mines of Idaho are, in general, doing well.

The Ontario Silver Mining Co., of Utah, since the commencement of operations in September, 1874, has paid in dividends to stockholders \$1,900,000, and its development is still progressing. The Stewart Gold Mine, located in the Bingham district, has been incorporated with capital stock of \$6,000,000, and the results of its workings are thus far so satisfactory that additional stamps are being erected.

Several valuable quartz claims have recently been discovered in Calaveras and Tuolumne counties, California, promising to be richer than any preceding discoveries, and a revival of prosperous times is confidently anticipated there. From many other counties in California cheering accounts of mining conditions are received from Mono, Amador, San Bernardino, Contra Costa, and others, and everywhere there is evidence that we have much more to learn of the mineral wealth of the State. The Idaho Mine, of Grass Valley, Cal., yielded \$47,000 worth of gold in October, and the 111th dividend was paid, making a total distribution of \$2,510,000. In 1870 this mine was offered in England for £20,000.

Nowhere are richer ores found than those constantly reported from Arizona, and so important are the mining interests there now that it cannot be long, we think, before some way is discovered to escape from dependence on San Francisco reduction works.

The Comstock Mines, of Nevada, are with scarce an exception promising better returns than for many months past; but as public faith in them departed with the late disastrous stock speculations in San Francisco, other mines are preferred for investment.

At no time has there been so universal an interest in mining enterprises as is now manifest in every direction. The snags and quicksands having been well defined by their predecessors, the miners and investors of to-day need only to exercise ordinary caution to safely arrive at desired results.

THE YIELD OF PRECIOUS METALS IN 1878.

Wells, Fargo & Co.'s annual statement of the precious metals produced in the States and Territories west of the Missouri River, including British Columbia, and the receipts in San Francisco from the west coast of Mexico during 1878, show the aggregate products to be as follows: Gold, \$38,956,231; silver, \$38,746,391; lead, \$3,452,000—the total being less by \$17,267,132 than for 1877. California shows an increase in gold of \$2,068,000, but a decrease in silver, etc., of \$1,323,000. Nevada shows a total falling off of \$16,398,341, the yield from the Comstock being only \$21,295,043 as against \$37,911,710 for 1877. Montana shows a marked increase, all in silver. Utah shows a falling off of over \$2,000,000, but nearly \$1,000,000 of it is caused by reduced valuation of silver and lead bullion. Although Colorado shows \$1,680,802 less than for 1877, the yield has been really greater, as the reports for 1877 duplicated the product of certain localities, but the duplication was not discovered

soon enough to be corrected in the statement for that year. The production by States and Territories is as follows:

California.....	\$18,920,461
Nevada.....	35,181,949
Oregon.....	1,213,724
Washington.....	73,311
Idaho.....	1,868,122
Montana.....	9,763,640
Utah.....	6,064,613
Colorado.....	6,232,747
New Mexico.....	453,813
Arizona.....	2,287,983
Dakota.....	2,215,804
Mexico (west coast).....	1,594,995
British Columbia.....	1,283,460

The bullion from Comstock lode contained 45 per cent of gold and 55 per cent of silver. Of the so-called base bullion from Nevada, 30 per cent was gold. Of the whole product of the State, 35 per cent was gold. It is probable that the yield of gold and silver from all sources named for 1879 will not greatly exceed \$70,000,000.

Correspondence.

The American Middlings Purifier Company.

To the Editor of the Scientific American:

In your last number you quote, with a head note indicating entire sympathy, an article from the *American Miller*, which records two decisive defeats recently sustained by the American Middlings Purifier Company—one before Judge Blatchford, against Vail, Shotwell & Co., and one in Richmond, Va., against the Haxall-Crenshaw Company.

Now as to the facts. In the case of Vail, Shotwell & Co., Judge Blatchford granted the injunction instead of refusing it, the difference being that the plaintiffs prevailed instead of the defendants. It might be of interest to you to know more of the particulars concerning this decision. The case was before the court upon an interlocutory motion for an injunction, not upon the final hearing. The defense was conducted by the Millers' Association, it paying the expenses for experts, attorneys, etc. The argument was thorough and exhaustive, continuing through several weeks, as it was a test case for that circuit. After this elaborate argument the case was taken under advisement, and before the judge had prepared his opinion the defendants filed an *ex parte* suggestion to the effect that they had become insolvent and did not intend to resume the manufacture of flour, and withdrawing objection to the issuing of the injunction as prayed for.

The decisive victory achieved by the defendants was, that by this timely surrender they prevented Judge Blatchford from filing an opinion sustaining the patents. The bad faith of their course is apparent from the facts that the suit, although in form against Vail, Shotwell & Co., was really a test case against the Millers' Association; that the defendants were no more insolvent when the surrender was made than when the case was argued; and that the expenses incurred by the Association far exceeded any damages which could have been recovered in the particular case. In other words, this is only one of the tricks by which infringers hope to exhaust the purse and the patience of the patentee whose rights they ignore.

The other decisive victory is found in the fact that a bill was filed against the Haxall-Crenshaw Company, and an answer put in; there it rested. Some months ago the defendants obtained an *ex parte* rule on the plaintiffs to file security for costs or show that they were carrying on business in the State. The rule not having been served on the plaintiffs, and their attorney having no knowledge of it, the cause was dismissed for non-compliance. Of course such an order would be set aside upon motion, but no evidence having been put in upon either side, the plaintiffs preferred the less troublesome and less expensive course of filing a new bill, the costs being about \$12.

It is upon such chaff as this that the milling journals feed their subscribers, and from which they manufacture great triumphs; because they are the organs of the millers' associations, and these associations must constantly stimulate their members to pay their subscriptions, which are for the avowed purpose of resisting payment for any patent, of any kind, for any purpose, connected with their business.

Why the SCIENTIFIC AMERICAN should sympathize with these objects I cannot understand. They are simply combinations of manufacturers who extensively use patented machinery to defeat the claims of all patentees.

If you think that the so-called "Cochrane ring" is composed of such bad men, or has pursued such an evil course, or owns such vicious patents as to place them outside of ordinary laws and rules, I would be glad to disabuse your mind in those particulars.

The whole of their offense is that they hold patents which are being infringed in several thousand mills. The infringers are numerous, influential, and arrogant. They act upon the maxim adopted by other powerful combinations, that it is cheaper to fight patents than to pay for them.

I send you a list of the persons who compose this company. A very little inquiry will satisfy you as to who and what they are.

The course pursued by them has been to endeavor to collect a very small compensation for the use of their patents. When this was refused they sued an infringer of large wealth who was well able to defend himself, and who owned adverse patent interests of great value. The case was tried and the Cochrane party were beaten. Thereupon they appealed to the United States Supreme Court, where all of

their positions were sustained and the patents fully vindicated. They renewed their efforts to obtain from millers about one hundredth part of what would be due on a strict accounting. The charge was then made that the former decision in their favor had been obtained by collusion. This charge they promptly met, and the Supreme Court, after a thorough investigation, reiterated its opinion as to the validity of the patent, and said, "We see no ground to believe that the appellants are chargeable with any collusion with the appellees in this case in reference to the argument of the appeal. On the contrary, the weight of the evidence is that they repelled any arrangement or proposition which might look to that end."

All compensation having been denied them, they commenced suits against about half a dozen parties who were representative men, and one or more of these suits have been diligently prosecuted for the purpose of finally settling every question which it was alleged had not already been passed upon by the Supreme Court. All the others of the milling fraternity have been left undisturbed, unless it be by their own consciences. No miller who has offered to settle, even upon the most absurdly low terms, has had his offer refused.

Mr. Cochrane, the inventor and patentee of this new process, found that he was utterly powerless to cope with an army of infringers; he, therefore, associated with him a few persons who could provide the means for carrying on the expensive litigation which must ensue unless he abandoned all of his rights. Out of this has grown the cry of the "Cochrane ring."

If the inventor stands alone, he is pushed aside as of no account whatever. If he obtains assistance to vindicate his rights, he is met with the cry that an infamous ring is trying to oppress and plunder the poor manufacturers.

In sober truth, the persons denounced in the article you quote are fighting not their battle alone, but the battle of all inventors. If they should conclude that the odds against them are too great for successful resistance, and give up the unequal contest, what will have been gained and lost? Merely this, that the story of Whitney and his cotton gin will be once more repeated, and the rule again established that the more valuable an invention is to the public, the less beneficial it is to the inventor. If a person devises something which meets the wants of a multitude of persons, they can help themselves to the fruits of his labor and combine to resist any demand for compensation, however moderate, and ruin him by litigation in which he must bear all of the expenses of one side of the contest, while those of the other side are divided among several thousand.

It is a mistake to suppose that these combinations are directed especially against the Cochrane patents because there is something exceptionally obnoxious about them. They are merely associations of those engaged in an important branch of industry to resist by their joint action all attempts to compel any of them to pay for the use of any patent. These particular patents are more extensively infringed than any others, and therefore the opposition to them forms a bond of union for a larger number of persons who are animated by this spirit.

A candid examination of the facts will satisfy you that there was never a case where the owners of a patent had better grounds for believing in the entire justice of their cause, where their demands were more moderate or have been urged in a greater spirit of forbearance and conciliation.

Of course it is within the limits of possibility that the Cochrane patents are invalid, or that some of the parties we have sued do not actually infringe them. These are the chances of litigation which we must take; but what we protest against is that a body of men, who are charged with being infringers, should by "damnable iteration" be able to induce those who are in the main friendly to patents to believe that there is something disreputable in a patentee associating with him honorable gentlemen, for the purpose of asserting his rights and vindicating his patents against those who are too strong for him to resist singly handed.

Very respectfully, your obdt. servant,

CHAS. F. PECK,

Secretary of the American Middlings Purifier Company.
Washington, D. C., Jan. 6, 1879.

Steam for Thawing Frozen Earth, etc.

To the Editor of the Scientific American:

As you suggested the use of steam for thawing frozen ground, I thought you might feel interested in the following experiments.

The chief of our fire department recommended the construction of a portable boiler, with a suitable nozzle and tube connection, for thawing out the fire plugs. He also stated that it would be useful in excavating trenches for repairing service branches. The city plumber did not believe that it would be. Both were positive, and a wager and trial were the result.

A nozzle of ¾ inch gas pipe, reduced to ¼ inch at the point and formed like a cross at the top, for convenience in handling it, was attached, by rubber hose, to the boiler used for heating the water in the steamer of Company 1. In 30 minutes after steam was first turned on they had a hole 8 inches by 12 inches through the frost. Steam was used at about 35 or 40 lbs. There was one inch of frozen snow on the bricks, and the ground was frozen for a depth of 2 feet. The thermometer stood at -6° in the morning, but had risen to 15° above zero at the time of the trial. The hose coupling parted twice, which caused the loss of a few minutes.

Newport, Ky., Jan. 10, 1879.

C. P. B. Jr.

AMERICAN MECHANICAL GENIUS.

BY W. J. STILLMAN.

The World's Fair, lately closed, has, like the previous ones, been a great triumph for American inventors. The victory was so clear and so remarkable that one might say, as in the yacht race, where the America won her blue ribbon, that no nation was second. The case has given rise to some discussion, and the London *Times*, in its editorial comments on the subject, takes the simple and comprehensive ground that the admitted superiority is due solely to the necessity of providing for deficient labor by mechanical contrivance. This would be a satisfactory solution, to *Englishmen*, if it could be maintained; but, unfortunately, it does not account for the facts; it is a plausible but incomplete theory, that would account for many new inventions, but not for the better workmanship which makes so many new inventions possible and successful in America which are not so in England. A simple and well known case which negatives the *Times'* theory is that of the revolver. No one can say that the necessity which incubated pistols sat more heavily on America than on the older and military states of the world. Moreover, the revolver has been invented at least two centuries, and may be found in various forms in all the collections of mediæval arms in Europe. No English gunsmith who studied his business properly, should have been unacquainted with this old weapon. Only, it seems never to have been a success. The reason of its revival in America was simpler than the *Times'* theory: the quality of the workmanship employed on it was such that a perfection of adaptation of the mechanism which revolves the cylinder was possible, and the operation of it became automatic and infallible.

One can hardly say that a more dire need of telegraphic operation obtained in America than in England; in point of fact, an imperfect system of communicating by electricity was used in England before Morse turned his attention to it. Morse was driven by no necessity to use a telegraph—probably cared less for the actual benefit of the invention than any operator in cotton even at that day. But he saw the imperfection of the appliances, and invented the relay magnet which made the recording of an electric impulse possible. And to this day the majority of all improvements in telegraphing are invented in America. There is here no question of carrying labor where it is most wanted by mechanical appliances, for the greater need, if that can be called need which created its own demand, was on the other side of the Atlantic, to say nothing of the greater number of scientific investigators.

England had a large army and pretty constant occupation for it, somewhere, which did not prevent Englishmen and the English government from going on with the old system of making guns by hand, and clumsily, until from the American machine shops was turned out the mechanism which set Enfield going on a new basis. The Waltham watch works are another case in point. A large portion of the mechanical intelligence of England was employed in watch making, and it still is so, but the watch made by the Waltham workman, without any novelty in invention, is a better watch, at a given cost, than the English. When Whitworth came to America to study the American system of rifling small arms, he found no new principle applied or variation in the general design from English rifles, but he found a precision of workmanship which few men in England, besides himself, had the mechanical *finesse* to appreciate. The external differences were very trivial, and generally the English gun showed a luxury of mere finish which quite shamed the rough American gun; but I never knew an Adirondack hunter, in my hunting days, who would accept an English rifle as a gift on condition of habitually using it. Yet the English gun cost, on the average, five to ten times as much as the American, while, for practical result, it was not to be compared to it.

The difference in every case was in the fact that a higher grade of mechanical intelligence was employed by the American—a keener and finer perception of what fitted the case—a mental micrometer which discovered hundredths where the Englishman's only found units. This, of course, Englishmen in general will not admit, but it so happens that I have often had occasion to employ good English workmen in England, and I have invariably found that in the intelligence to apprehend fine degree of fittingness, precision of shaping, and especially capacity to catch a new idea, the Englishman was far inferior to the American. I remember a case in point, which I will relate in detail, as it is characteristic. In a journey from New York to London I had lost out of my valise a small swage for shaping and compressing the conical bullets for a hunting rifle I carried with me. It was a simple affair, a bit of steel bar bored into a couple of inches, and then at the bottom of this drill hole the conical reamer which shapes the shot is sunk its full depth. A plunger, driven down by a hammer, forms the base of the shot and compresses it. The whole cost, in New York, \$2. To replace it I went to all the gunsmiths between Regent street and St. Paul's, but could not find one who would undertake it, until finally I was directed to a high class workman who had a small shop and worked for the larger manufacturers. I explained my want to the minutest operation, gave him a sample of the missile to work from, and at the end of three days, employed in failures, he brought me a curious affair made by turning out in a lathe the form of the shot in a kind of die, which was then tapped and screwed into a tube made of a piece of gun barrel of the requisite bore, to which was added the plunger. He had not in the least understood my description and drawing, and could not

conceive any other way to make the thing than that he had employed. Of course it split at once under the pressure and had to be thrown away.

I am myself sometimes attacked by a mechanical idea, and now and then it results in an invention. It happened that one one occasion the product was a photographic camera obscura, which involved some mechanical principles new to this kind of work. I made an elaborate working drawing full size, with details of all new parts in separate drawings, and sent them to a camera maker who had the highest repute in London, but after some months they came back with a message that the arrangement was not practicable. I then went personally with the drawings to another workman, who was really the most ingenious in this branch I ever found in England, and even with him was obliged to make a wooden working model of the whole thing before I could make him see that it would work, and I had to watch the construction from beginning to end, intervening at every new step to keep it what I had planned.

At another time I had got from America a piece of apparatus which I wanted copied. An important part of it was a very light bronze bed plate, rather complicated for a casting, but in the American article done well and cheaply. The manufacturer to whom I took it looked at it in admiration and dismay. "I can't get casting like that done in this country," said he; "there is not a founder in London who can do it," and he was obliged to substitute sheets of brass screwed in place and supported by wood.

A still more convincing case has lately occurred in my experience. I have a Remington gun, to which I wanted some additions made, and sent it, being on the Continent, to the Remington establishment in London, where English operatives are employed. After the characteristic delays, which I never found wanting in English workshops, the gun came back to me with the desired alterations, but done in a clumsy and uninventive manner, which any ordinary American gunsmith would have been ashamed to send out of his workshop. Yet here was, or was supposed to be, the American intelligence presiding. I have had the same things done at home at half the cost, and in a manner which left no ground for comparison.

These are instances of what I have seen many times. The English workman in general is insensible to those nice degrees of excellence, neatness, and precision in the manipulation which the American workman catches so readily.

The success of American invention, in my opinion, is due to the highest excellence of the mechanical manipulations by which they are worked out—an excellence compared to which French work generally is flimsy and English clumsy—the former gives way, and the latter is not exact. I know Englishmen of extraordinary mechanical genius, but their most ingenious ideas are carried out at Paris.

But if the success of invention is due to the finer grain of the workman's brain, the invention itself is due to other qualities more multiplex and less easy of being demonstrated. First, I believe, is the freedom from deference to precedent which characterizes the American character in every branch of activity. This, of course, is due simply to position. We had no precedents, except such as it was impracticable to follow, and the habit of having none has liberated thought in every way. The contempt for authority, which in excess proves so often disastrous in our politics, is an almost unmitigated advantage in all mental processes except the purely artistic. The American in his better development gives that devotion to law which the Englishman gives the authority; but the law is universal in its application, while authority is narrow and restricted to what has been done. This distinction imbues the whole national character. The Yankee if menaced with arrest wants to see the warrant; the cockney accepts the mission of the "bobby" without any other demur than perhaps to look at his number.

But still behind these qualities lies the essential inventiveness—an intensity of imaginative vitality which is in the composition of the composite race which we are, the power which in art and poetry has held and will always hold the world in reverence, and which had such a glorious sunrise in Greece from Homer to Praxiteles, the power which no man can explain and no man can acquire, which seems to come to man or nature without antecedent or succession, and of which we know mainly that it generally goes in schools. There is a curious and close likeness between the character of the Greek and the American, which goes even into the type of the physique, and which I have heard often noted in Greece, both by Greeks and foreigners. This very element of imaginativeness is one of the strongest components in the similarity of the national characters. It will be curious for those who will be here to see it, to follow out the parallel which certainly does now exist and that which will obtain between the republican Greek of 700-500 A. C., and the republican Yankee who will exist about 2000 A. D.

So far as England is concerned there is a negative element which is disastrous for the development of invention in that country in the patent law system, perhaps the worst that exists in any state in Europe—worse, actually, than none at all.

I have had some personal experience with it, and feel justified in saying that I do not know which is worst, the scheme of law, the manner in which the patent officials do their duty, or the curious ignorance of all principles of mechanism shown by the judges who sit for the decision of patent cases. Neither the legislative nor the judicial authorities seem to be able to understand the interests, not of inventors merely, but of invention.

Labor Troubles Abroad.

The ship builders, mine owners, iron workers, and in fact nearly all the manufacturing industries of Great Britain, find it imperative to reduce the prices of labor in their various establishments. This produces an uneasy feeling throughout most of the manufacturing districts of England, and the American *Architect* thinks it looks as if the battle so portended were likely to be one of the severest of the labor war. However it may end, it can hardly be other than disastrous. The iron trades in Great Britain are now in an exceptionally critical condition, owing to the successful competition of other countries, particularly of the United States, and the coal trades necessarily suffer with them. If the men succeed in the struggle in either trade—or in both, for it is likely that they will succeed or fail together—they will succeed in adding a heavy load to an industry that already shows symptoms of paralysis. If they fail, they will still have done by forced stoppage an injury to their employers of which they must themselves feel the burden; but they will waste a great part of their own strength in the conflict, for they will probably not give up early. The funds which they have laid up for the relief of the disabled among them, or of the families of those who die, will be eaten up very fast, and in spite of this the hardships which it was their purpose to avoid will have been increased. It might have been hoped that the fortune of the Oldham strikers, who, having in a few weeks spent more than a quarter of a million dollars in the effort to force their employers to pay them wages which the condition of business would not allow, found themselves obliged to yield, would have made other unions slow to follow their example. But there is not much hope of avoiding the waste and injury of strikes so long as working men are taught or allowed to look upon every diminution of wages as an oppression. Their greatest benefactor just now would be he who should teach them that no class in a community can expect to be exempt from the suffering and loss of a period of general adversity, and that to strive against such loss with violence is to kick against the pricks; and should moreover lead them to look for comfort in the doctrine that even a fall of wages does not necessarily mean a loss of comfort when the cost of living goes down with them.

American Reapers and Binders in New Zealand.

From the New Zealand *Country Journal*, a monthly publication devoted to agriculture, pastoral, and horticultural pursuits of New Zealand, we learn that our reapers and binders are finding their way into that far away colony. At present, so far as we are aware, says the *Country Journal*, there are six different self binders in the American markets, viz., the McCormick, Wood, Osborne, Marsh, St. Paul, and Buckeye, each claiming superiority over its fellows. With regard to the merits of the several machines as yet imported, it is not the province of this paper to express any opinion in favor of any of them. The farmers of the country must be the judges; time only can decide which is really the best, although there is no reason why one may not be quite as good as another. So far, those in use have their several admirers, and doubtless each has its own peculiar merits. As yet the trials have not been sufficiently varied or numerous to justify any fixed opinion of any value, which would laud one maker's machine over the others. As we have just remarked, time and the farmers themselves will decide. At the conclusion of next harvest the country will be in a better position to judge. The only objection, adds the writer, and the same we believe prevails here, which we have heard raised against these machines is, that the wire cannot be kept out of the straw, and that it will prove detrimental to horses and cattle, when cut up with the chaff.

What Civilization and Invention Do.

One of our daily newspapers said the other day, just after recounting a series of disasters, that there seems a fatal quality belonging to every one of civilization's conveniences, inventions, and improvements. The aboriginal Manhattan was safe if not always comfortable in his wigwam. Our houses serve as man traps, burning or crushing out scores and hundreds of lives annually. Our elevators fall and kill their inmates. Steam boilers in the next building, of whose existence we are not aware, suddenly explode, mangling and scalding people not previously aware of their existence. The locomotive averages over a victim a day "killed on the track." Gas leaks accumulate and explode, smashing people and furniture. Drawbridges lure people to tumble into the water and drown. New chemicals used in manufactures explode with terrific force, and nobody is left alive to tell what it was or how it ignited. Even fine flour siftings and pulverized starch are regarded as suspicious characters full charged with explosive and deadly intent. Ice making in range and water pipes converts them into engines of destruction. Though sewers carry off filth, they also extract its deadliest essence and send it back into our houses as "sewer gas." Civilization is full of peril. The original Manhattanese had not to incur these daily risks of our lives.

COATING COPPER PLATES WITH IRON.—Prof. Böttger recommends the following solution for coating copper plates with iron: Ten parts of ferrocyanide of potassium and twenty parts of tartrate of soda are dissolved in 220 parts of distilled water, adding a solution of three parts of sulphate of iron in fifty parts of water. Caustic soda solution is poured into the mixture until the Prussian blue formed is redissolved.

ATMOSPHERIC AIR AND THE VACUUM.

The origin of the first pneumatic apparatus, the syringe, is unknown. The fact that the piston of the syringe could not be withdrawn without the cylinder becoming filled with air, water, or some other liquid, constituted one of the experimental proofs of the theory of the "horror vacui" accepted by ancient philosophers. The Greek observed that combustion, taking place in a vessel rarefied the air. By means of the introduction of a burning light into a bell-shaped vessel and then pressing the latter to the skin, they applied cupping glasses in the same way as it is done at the present day. This being an inconvenient method, however, they looked for some different means. Hero, of Alexandria, in the 56th chapter of his celebrated "Treatise," describes "the construction of a cup sucking without the aid of heat." The closed end of this cupping bell was separated from the mouth by a transverse partition situated near the latter. Into the closed end was inserted a tube with a stopcock. The partition also was provided with a valve, by which the two compartments could be brought into communication at will. With the valve between the compartments shut, the air was sucked out of the upper compartment through the tube, and the stopcock closed. The bell was then applied firmly to the skin, and the valve opened; the air within the entire bell was thus rarefied, and the skin consequently raised by aspiration.

This same idea was brought out, after a lapse of many centuries, by Otto von Guericke. He used a hollow sphere with tube and stopcock, from which the air was removed by a pump. Otto von Guericke, born in 1602, was burgo-master of Magdeburg, in Germany, and spent his hours of leisure, which his duties as a public officer and his frequent diplomatic missions allowed him, to study and experiment on scientific matters. His attention being first called to the problem of creating an entirely empty space by a treatise on that subject, he set out to experiment at once. He tried, at first, to remove the air from a tightly closed cask. For this purpose he used a pump, provided with the necessary stopcocks, reaching to the bottom of the cask. The latter being filled with water, he commenced to work the pump, but as he removed the water the outside air forced its way into the cask by minute openings in the wood, causing a noise as if the water within was boiling. He next used a hollow sphere of copper provided with a tube and stopcock, which was screwed airtight to a powerful pump, after being filled with water. It required two stout men to operate the pump and remove the water. Then the stopcock was closed and the copper globe detached. The stopcock being now opened, the air rushed into the hollow sphere with such force that anything coming within reach was caught by it, and the hand held over the opening was severely injured.

These experiments were repeated at Ratisbon, in 1654, before the German Diet, the Emperor, and the most celebrated statesmen and scientists. The Archbishop of Mayence became so interested in them that he induced Otto von Guericke to leave Magdeburg and bring his apparatus to his palace at Würzburg. At the latter place the celebrated mathematician Schott, a Catholic priest, and several other servants, assisted Guericke.

The latter's researches obtained publicity for the first time under the title of "The Magdeburg Experiments," in Schott's work, "Ars Hydraulico-pneumatica," and later, by introduction, into the work of the same author, "Technica Curiosa" (lib. i., "De Mirabilibus Magdeburgicis.")

The book containing the most complete account of the discovery, however, was published in 1672, at Amsterdam, under the title "Ottonis de Guericke Experimenta Nova (ut vocantur) Magdeburgica, de Vacuo Spatio," of which the author is unknown. The pneumatic machines were not very portable, and as Guericke wished to repeat all his experiments in a comprehensive way before his sovereign, the Elector of Brandenburg, he constructed an apparatus possessing a marked improvement on his former machines.

It consisted of a vertical cylinder of brass or iron, supported by a tripod made of iron (Fig. 1). At its lower end the cylinder had a stopcock, while within a piston and rod could be moved up and down by means of a stout lever fastened to one of the legs of the tripod. The piston was provided with a valve. On the upper extremity was

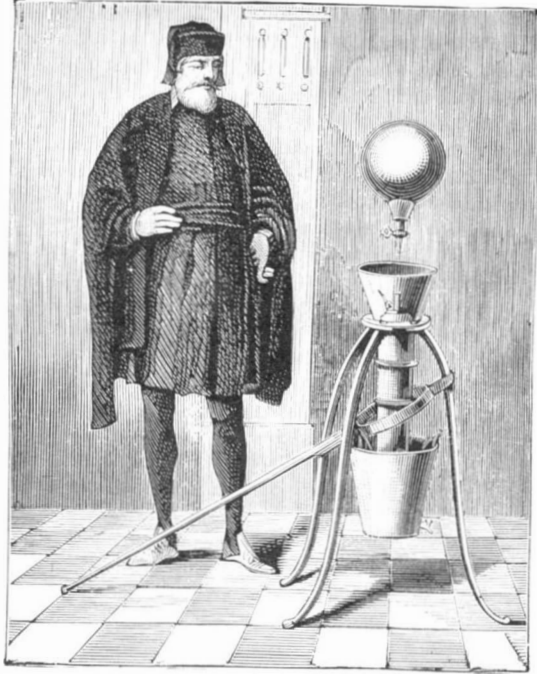

Fig. 1.—OTTO VON GUERICKE'S ORIGINAL AIR PUMP.

fastened a hollow sphere of stout glass provided with a tube and stopcock, similar to the copper globe previously used. This machine being very exact and powerful, a prolonged series of experiments were then made. One of the most

celebrated is that with the so called "Magdeburg Hemispheres," used in schools at the present day, and constructed substantially the same as those made by Guericke. They consist of hollow brass hemispheres, as shown in Fig. 2. The two hemispheres were pressed together and attached to the pump, by which a vacuum was created; when the apparatus was detached from the pump the two hemispheres adhered with great force.

After his first experiment with this apparatus, in 1656, Guericke stated that six powerful men could not separate the two parts. Afterwards, in 1657-64 ("Technica Curiosa," Schott), he said that a more complete vacuum was attained and the diameter of the sphere increased, so that he could hitch twelve horses to each side, and have them pull at their full power without being able to effect a separation. These experiments created a profound sensation. It was conceived gradually that it was the pressure or weight of the atmosphere that produced such astonishing effects. Calculating the pressure exerted on the surface of the two hemispheres, accepting the vacuum as perfect, we find it equal to the weight of a column of mercury of barometrical height, having a base with an area found by the formula πR^2 , R being the radius of the sphere. The weight exerted will be $\pi R^2 \times 76 \times 13.6$.

A great variety of experiments were made. By allowing the air to enter slowly, by opening the stopcock slightly, the adherence of the hemispheres was rapidly diminished, and soon ceased altogether. Otto von Guericke said regarding this: "How is it, that a mere breath of air can accomplish what was impossible to do by the power of 24 horses?"

The separation may be effected also in a different way, of which the learned burgo-master did not think. When the hemispheres are joined together, and the vacuum within as nearly as possible complete, they are suspended under a glass bell, in which a vacuum is then also created. As soon as this is done the weight of the lower hemisphere will be sufficient to separate it from the upper one. Guericke attached one hemisphere to a hook fastened in the body of a gallows, and the other to a chain, running over pulleys, and carrying at the end a platform on which weights could be placed. When a sufficient load was placed on the platform the hemispheres separated, with a report similar to that of a cannon. Separation was also produced by men pulling on ropes running over a compound system of pulleys. Guericke also constructed an apparatus which he described as a "glass globe capable of moving 50 men against their will." It consisted of a cylinder resting on a support, and provided at the base with a coupling and stopcock. Within was contained a piston with a long rod. The piston was drawn out as far as possible, and the 50 men attached to the rod by ropes running over pulleys. To the lower end of the cylinder was now screwed a big glass globe previously deprived of air. As soon as the stopcocks were opened the air contained in the cylinder was suddenly diffused throughout the glass globe, thereby creating a partial vacuum in the cylinder. The piston was consequently forcibly drawn into the cylinder, while the men attached to the ropes were suddenly jerked forward in spite of their resistance. This experiment was afterwards modified by attaching the cylinder to a chain hitched to a platform bearing a great weight. When the air was removed from the cylinder, as shown in Fig. 3, the platform was lifted from the ground and held in suspension in spite of its weight.

RECENT investigations indicate that the great kidney worm (*Strongylus gigas*) which exists in the kidneys of the horse, dog, and sometimes in man, lives in fishes in its young state; and the observations of Dr. Bertolus almost furnish proof that people contract the Swiss or broad tapeworm (*Bothriocephalus latus*) by feasting on imperfectly cooked trout. According to Professor Van Beneden, however, the latter parasite is at present known to occur only in Russia, Poland, and Switzerland. All full grown fishes sold in the shops as food are liable to contain entozoa.

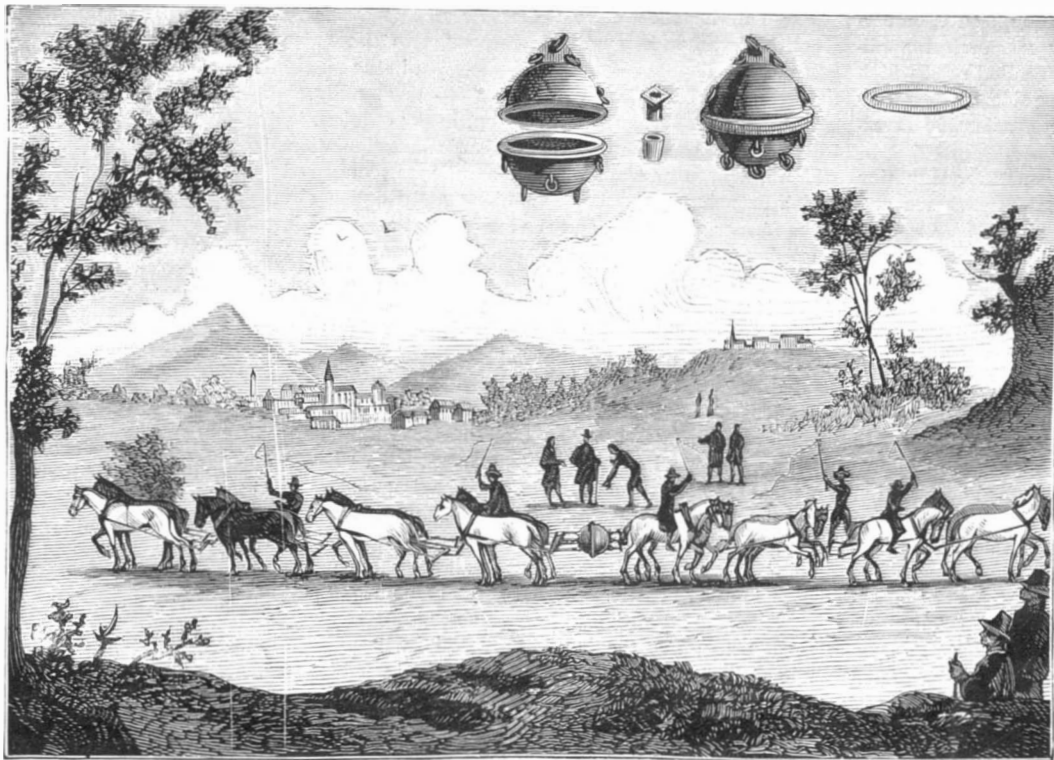

Fig. 2.—ATMOSPHERIC PRESSURE EXHIBITED BY THE HEMISPHERES.

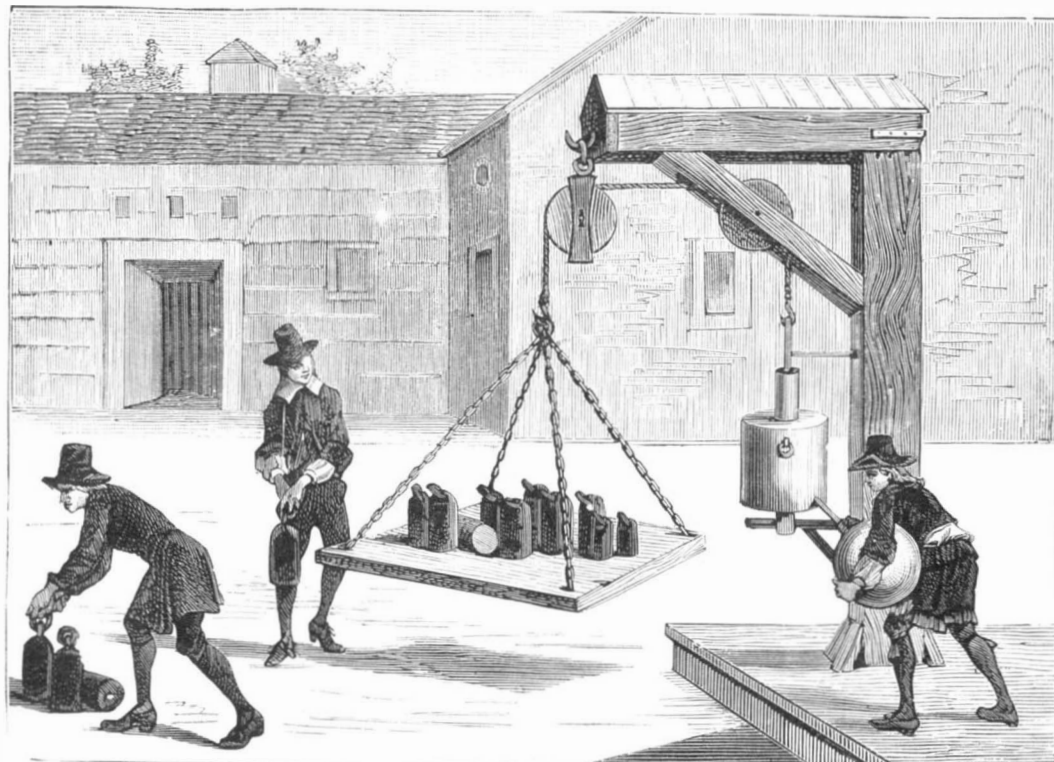

Fig. 3.—AIR EXHAUSTED FROM A CYLINDER BY MEANS OF A VACUUM BALL.

THE PORCUPINE.

The porcupine is an herbivorous animal belonging to the order *Rodentia*, or gnawers, and the genus *Hystrix*. The latter comprises a large number of curious animals, which are distinguished principally by the long, horny spines which cover the larger portion of their body.

The porcupine is probably indigenous in the northern part of Africa. It was known to the ancient Greeks and Romans, who, it is supposed, introduced it into Europe. Aristotle mentions that the animal slept through the greater part of the winter. Pliny tells us "that it shoots off its spears like arrows."

Although the porcupine is, in reality, rarely over two and a half feet long, it seems to be much larger on account of the long spines covering it. The tail is from four to six inches in length, and its height at the shoulder is about one and a half to two feet. Its weight varies between twenty and forty pounds. The snout is short and broad, and the mouth is furnished with powerful incisors. The upper lip is very thick and provided with numerous long, shining black bristles. The neck is covered with long, flexible bristles, which may be raised or laid down smoothly at the will of the animal. The back is covered with sharply pointed spines of various lengths, which are held loosely only in the skin. Hence they are liable to fall out when the animal moves about violently, as for instance when defending itself. This has no doubt given rise to the story related by Pliny. Along the sides of the body the spines are shorter. The longer spines are quite flexible and about fifteen or sixteen inches in length, while the shorter ones measure about eight inches, being at the base about one fifth of an inch in thickness. In the interior they are filled with a spongy mass. Both the spines, as well as the bristles on the neck, are of a brown color, intercepted by white rings; the point and the root are also white. All the spines can at once be raised into an erect position by the contraction of a powerful muscle, which extends all over the back, directly under the skin. The belly is covered with dark brown hair, and the neck is encircled by a white band.

The porcupine leads a dreary, solitary life; during the day it hides away in its burrow, from which it emerges at night to look for food. This consists of herbs, roots, and fruit. The porcupine needs very little water, all that is necessary being supplied by succulent fruits.

It does not undergo regular hibernation, although it only emerges at great intervals from

its burrow during the winter. When attacked, the porcupine raises the spines, rattles with the tail, and then turns its back to the enemy to advance, or rather retreat, against him, in order to bury the spines in his flesh. Once embedded in the latter, they are difficult to remove, and, when allowed to remain any length of time, they cause suppuration, which has in some cases been followed by death. Although the animal could inflict serious wounds by biting, it never uses its teeth defensively; this is probably due to an instinctive desire to protect the nose. The latter is very sensitive; a blow even with a cane is sufficient to stun or even kill the animal; when pressed to the last, it therefore sticks its head under the belly and rolls up into a ball.

The porcupine is hunted extensively in the southern parts of Europe and in Africa on account of the spines, which are of some commercial value. The meat is also esteemed by many. It is hunted at night by dogs. When brought to a stand it is either caught alive by means of a large cloth thrown around it, or the hunter, allowing it to approach him, keeps it off with a stick, steps back, and immediately inflicts the deadly blow on the nose.

In imprisonment it is easily tamed, and, when caught young, it learns to know its master and follows him like a dog. It never loses its timidity, however, and the least unusual noise or strange object throws it into fits of fright and anguish.

Summer Flowers in Winter.

Roses are popular at all seasons. At midwinter no rose is held in higher esteem in New York than the Jacqueminot, or "Jack" rose, as it is commonly called. The "Jack" is only an ordinary June rose such as may be seen in any roadside garden on a summer's day. The secret of its popularity lies in its rarity and in the difficulty of bringing it to perfection at midwinter. To do this it is necessary to dig up the plants after they have done flowering in the summer, freeze them in an ice house, allow them to remain frozen for a while and then restore them to life and force them to maturity with a high degree of heat.

Next to the roses the favorite flowers for this season are the lilies of the valley, a few sprays of which will pervade a whole room with their sweet subtle fragrance. They are very rare, and sell at New Year's for 20 and 25 cents a single spray. That they are so costly is in a large measure owing to the fact that to be produced in full perfection at this season they, too, must be taken up and frozen after flowering in the summer, and afterward forced to a second maturity in the same year by great heat. By this freezing process the entire rotation of seasons is reproduced within a few months.

Physiology of the Brain.

Dr. Brown Séquard, formerly of this city, has removed to Paris, and about the first of December he began his course of lectures on physiology at the Collège de France. In his opening address, according to the *Lancet*, he made known the subject which it was his intention to treat of this year. He proposed to combat all the doctrines which are actually received upon the physiology of the brain, and especially those which have reference to cerebral localization. He will

Trichinæ.

Some investigations have just been completed by two Chicago microscopists as to the prevalence of trichinæ in the pork that comes to our markets, that seem worthy of record. Some time ago Dr. William T. Belfield, Demonstrator of Physiology in Rush Medical College, and Mr. H. T. Atwood, Vice President of the State Microscopical Society of Illinois, were asked by the Commissioner of Health, of Chicago, Dr. DeWolf, to examine specimens of pork taken at random from the hogs being slaughtered at the different slaughtering houses. Specimens from one hundred hogs were carefully examined, and in eight trichinæ were found, the number varying according to estimate from thirty-five to thirteen thousand to the cubic inch of muscle. This is doubtless approximately the average of infection of the pork brought to Chicago for packing. The trichinous disease among hogs—if disease it is—must be much more prevalent now than ten or twelve years ago. Then an examination of quite a large number of hogs in behalf of the Academy of Sciences showed only about one in fifty infected.

Messrs. Belfield and Atwood have experimented with rats and other animals, to which they have fed trichinæ, and have reached the conclusion that, taken in small numbers and not too frequently, any animal or man may eat these worms with impunity. A rat weighing two ounces was fed at intervals of two or three days a few trichinæ for six weeks, when it was killed. It was full of live trichinæ—which, immersed in warm water, would move vigorously—the estimated number in the rat being 100,000. During the six weeks the rat appeared perfectly healthy. Dr. Belfield felt so sure of the innocuousness of small numbers of the worms, that he made a practical test by himself eating twelve live trichinæ three weeks ago. He has not experi-

enced an unpleasant symptom to date. He believes a large per cent of our population are really infected with trichinæ. It is a fact in confirmation of the theory of these observers, that many of the infected hogs have received the trichinæ without symptoms of disease, certainly without any damage to their fattening qualities. It is surely impossible that eight per cent of all the hogs raised for market could get sick with symptoms approaching in severity those of severe human infection, without such a panic among farmers as would be noticed by the whole country.

Some experiments with different agents used for the destruction of the worms showed

that the best inexpensive agent was sulphurous acid; a very little of this acid, mixed with the brine in which pork is preserved or pickled, will kill all the trichinæ, without, of course, any damage to the pork for any purpose. The lowest per cent of the acid required to be effectual has not yet been determined.—*Medical Record.*

Recent Work at the U. S. Torpedo Station, Newport.

Premising that comparatively little has been done at Newport for the improvement of torpedoes during the past two years, owing to the smallness of the appropriations therefor, a special correspondent of the *World* writes that one of the most important discoveries made within that time has been Lieutenant A. R. Couden's improved method of determining the internal resistance of galvanic batteries. The method hitherto practiced at the station is described by Professor Farmer as follows:

"Introduce into the circuit of a galvanic battery a convenient rheostat and a suitable fine wire galvanometer. Open and adjust the rheostat until a convenient deflection is obtained (42° 21' is liable to least error); note carefully the deflection. Next reduce the total external resistance of the circuit one half. (This presupposes that the rheostat, as opened, offers more resistance than the galvanometer.) The needle will now be deflected more than it was at the first observation. If now another adjustable rheostat be used as a



THE PORCUPINE.

study the mode of action of the brain upon the spinal cord, and will discuss the question whether it is right to admit the existence of two brains or one only. He will then review all the lesions of the brain which are capable of producing physiological or morbid phenomena. According to Dr. Brown Séquard, each half of the brain possesses all the functions of the encephalon; it is capable of any act, and can perceive all sensations. He hopes to be able to show that it is not indispensable to admit the theory of the decussation of the nervous fibers of the right side to the left and vice versa, and that each half of the brain is capable of perceiving all sensations emanating from any point of the body.

Dr. Brown Séquard believes in the existence of cerebral localizations, but maintains that the localizations, instead of existing in certain limited points of the brain substance, are composed of elements disseminated everywhere. He then cited a certain number of facts which would tend to show that the center of speech is not situated, as Broca has stated, on the posterior part of the third frontal convolution of the left side. The eminent professor has already exposed his views upon this subject in an interesting discussion which took place before the Société de Biologie in 1876. It is not his intention to have recourse to experimentation to demonstrate the truth of his doctrines, but will bring forward pathological facts in support of them.

shunt across the terminals of the battery, this shunt can be so adjusted that the reading of the galvanometer shall return to the same position as in the first observation. When this is the case, the resistance of the shunt is equal to the internal resistance of the battery."

Lieutenant Couden conceived the idea that if the two changes, viz., shortening the resistance and applying the shunt, were made simultaneously, there would be at the first instant no movement of the needle, if the proper shunt were first chosen. He availed himself of the two keys used in manipulating the Wheatstone bridge to carry out the idea. The results were quite satisfactory, but the two keys being independent of each other and far apart required two fingers to press them, and sometimes failed to operate with complete simultaneity. To remedy this Professor Farmer had made for Lieutenant Couden a key with a single finger piece, but with two independent contact closers, which admitted of such adjustment as to secure the required simultaneous closing of the two circuits when the key was depressed. The apparatus as thus constructed operates with entire satisfaction.

Improvements have also been made in the method of splicing the torpedo cables and leading-wires now issued to ships. Mr. Farmer says that in all insulated wire now issued to ships for permanent wires, for spar leading-wires, and torpedo cables, the conductor consists of seven strands of small copper wire, and is therefore very flexible. Should it become necessary to join two pieces of cable together, it can now be done by knotting the wire by, first, a sheet bend; second, a reef knot; third, a carrick bend. The advantages over the earlier form of splicing are fourfold, viz., first, the splicing nippers and splicers in the supply box are abolished; second, instruction to the sailor is unnecessary, and the operation is more quickly performed; third, it is the strongest way of joining two pieces of wire; fourth, the electrical properties are all that can be desired.

The modification and improvements in the electric primer are as follows: In putting in the bridge great uniformity in length and consequently in the electrical resistance is obtained; rounding up the quills so that the primers will enter the vent guns freely; a method of "choking in" the quills and securing them firmly to the wires.

The United States steamer Trenton's electrical apparatus is a noteworthy result of discoveries at the torpedo station. A full description of it would occupy too much space, but it may be stated that it is for two distinct purposes—firing of guns and torpedoes, and calls and automatic fire alarms. That intended for guns and torpedoes is designed to place the firing under the control of a single officer stationed at some central point, who shall be able to fire any gun when it is ready, or either or both broadsides, or as much of a broadside as may be ready.

Professor Walter N. Hill has made a variety of experiments in chemistry, as pertaining to torpedo construction and firing, and below are given a few opinions he gives as a result of them. He states that liquid nitro-glycerine is readily exploded, as is well known to scientists, by five to ten grains of fulminating mercury, but when frozen he has never been able to fire it. When dynamite freezes to a loose, fine powder, he finds it may be exploded with tolerable certainty by the ordinary detonating fuse (fifteen to twenty grains of fulminate). In a large number of experiments with small amounts he found but very few cases when explosion did not occur. But in proportion as it is solidly frozen, that is compacted together, the explosion is less sure. It would be uninteresting to give particulars in detail of the experiments. It is sufficient to state that the conclusions arrived at are that an exploder containing fulminating mercury only will not fire frozen dynamite with any degree of certainty. In the experiments it did so twice, but in one instance it is doubtful if the charge was well frozen.

The present service torpedo has proved objectionable for several reasons, principally on account of its weight, lack of strength, and the great surface offered for resistance in being towed through the water, whether ahead or abeam. A new design has been perfected; it is of steel, and possesses decided advantages over the present service pattern, being stronger, lighter, and offering less surface for resistance. The cost of each steel torpedo is about \$60, and as even ten would be a very small number to experiment with it has been found impossible to make much progress. Their general shape is very nearly that of a sphere. Another feature they possess, an advantage over the service pattern, is the mode of attaching them to a spar or outrigger; the center of the torpedo case lies in a prolongation of the axis of the spar, and is secured to it by a conical cap permanently attached to the torpedo case, and also of steel, which is keyed to a metal cone rigidly secured to the end of the spar; this mode of attachment reduces the surface of the spar exposed to the effect of explosion, and the force is exerted in the direction of the length of the spar, the most advantageous for the spar and the boat. Further trials have been had with the improved spar, fitted with the attachments of spars to the forward guy and topping lift, and it continues to give good results, tows well, preserves its immersion, vibrates but little, and has stood the fire of twelve service 100-pounder torpedoes without any material injury. It has been found that, in the case of boat spars, if the spar is left free to recoil, the effect upon the boat and spar is reduced; the spar recoils usually from 10 to 15 feet, but not past the balancing point, therefore not coming into the boat. A ready man at the heel rope can easily, at this time, rig the spar in by a pull on the heel rope, leaving the launch free to steam without the

drag of the spar. Spars have been very successfully worked in this way at the station, and a number of spars have each withstood the explosions of six service boat torpedoes without any considerable damage. By this precaution the lifetime of the spar is prolonged.

A towing torpedo, capable of being towed on either quarter or shifted from one quarter to the other while being towed, has been designed, and the trials had with a little working model give promise of success with a larger and more practicable one.

Experiments have also been made with the fittings designed for fast torpedo launches, with a view to determine the requisite strength for a beam spar. The results have been satisfactory.

A small non-automatic hand lamp, constructed by Mr. Farmer, for use on the torpedo boat Lightning, has proved very advantageous as a means of signaling when its beams have been waved in the sky in a manner somewhat similar to the usual method of waving a signal flag. In dark and cloudy nights this method of signaling has some advantages, since the position of the lamp can be screened, as, for instance, by being sunk in a rifle pit, so that its exact location could not be determined at a distance.

Some experiments have been tried with parallel carbons arranged somewhat after the plan of the carbons in the electric candle of M. Jablochhoff, but a sufficient number have not yet been tried to warrant an expression of opinion as to the serviceableness of carbons used in that manner.

Experiments have also been made with the telephone in order to ascertain its suitability for communication between the bridge and the powder magazine, as well as between other parts of the ship. It has been found possible to communicate over a circuit of 22,000 ohms, having a stated capacity of eight microfarads, whence it is easy to see that it would be entirely feasible to communicate through an ocean cable between two stations that should be at least 500 miles apart. The rapidity of communication, too, is astonishing, since 145 words in 17 seconds were distinctly heard over a short circuit. This is at the rate of 512 words per minute. The possibility of communicating with way stations at a distance from the direct line, and without a loop, has been satisfactorily demonstrated by Professor Farmer and his assistants.

Captain F. M. Ramsey, United States Navy, is now in charge of the station, having succeeded Captain K. R. Breeze, who is now preparing a *résumé* of all the work that has been done at the torpedo station.

IMPROVED WINDOW AWNING.

With the ordinary wooden blinds placed on the exterior of windows it is only possible to open and close them one way. The annexed illustration represents an improved form

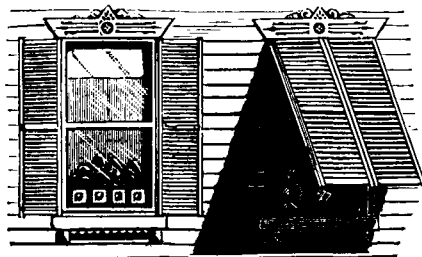

WINDOW AWNING.

of blind, window screen, or awning applicable to all windows in brick and wooden buildings where ordinary blinds are in use, and also to bay windows where there is little or no chance to swing blinds back. The improvement consists in constructing the blind so that it will swing on hinges as usual, and in addition to this the two halves can be drawn and fastened together to form one entire blind, and then quickly and easily adjusted to swing from a top horizontal hinge, instead of the vertical ones.

The blind can be used both ways, as shown in the cut, and the improvement may be applied to either old or new blinds; it is an economical and effective way of shading a window; it makes a perfect screen from outside observation; and it allows a free circulation of air. The view from the inside is not obstructed; blind fasteners are dispensed with, a bolt being used to hold the blinds together, and arms are provided which hold them open against the house. This kind of blind can be used in fall or winter, when a cloth awning has to be taken down to preserve it. Further information may be had from the Boston Blower Co., 2 Foster's Wharf, Atlantic avenue, Boston, Mass.

Carbolate of Soda for Whooping Cough.

Dr. Pernot describes in the *Lyons Medical Record* a very successful treatment of whooping cough with carbolate of soda. He places the carbolate of soda in a small porcelain crucible held above the flame of a spirit lamp, which keeps it in an unvarying temperature as long as wished. As the carbolate of soda becomes volatilized, the atmosphere of the sick room is impregnated with the vapor of carbolic acid.

When the crucible and lamp are not at hand, a satisfactory substitute is found in a fire brick heated enough to vaporize the carbolate. In numerous cases the following results have been obtained:

1. A notable diminution of the paroxysms of coughing after from two to ten days' treatment. 2. Less labored and

painful respiration. 3. Shorter duration of the paroxysms of coughing. 4. The most confirmed attack of whooping cough remains *in statu quo* from the commencement of the treatment, and it always appeared to him to diminish more or less rapidly, but always in a time relatively short to its usual duration.

The vapors of carbolate of soda have valuable disinfecting and antiseptic properties.

It is worthy of note in this connection that the fungoid origin of whooping cough, asserted some years since by M. Svezzerich, seems to be confirmed by the recent researches of M. Yschamer, who says he has found certain lower organisms in the spittle of whooping cough patients—organisms not met with in any other disease accompanied by cough and expectoration. He claims, further, that the organisms in question are identical with those which, by their agglomeration, form the black points on the skins of oranges and the parings of certain fruits, especially apples. Thus, M. Yschamer, by inoculating rabbits with this dark matter, or even causing it to be inhaled by men, produced fits of coughing several days in duration, and presenting all the characters of the convulsive whooping cough.

How Roquefort Cheese is Made.

In an address on "Dairy Interests Abroad," at the International Dairy Fair, Mr. F. B. Thurber gave the following account of the manufacture of this variety of cheese:

The French Roquefort is made from the milk of sheep and goats, principally from that of the former. In 1866 250,000 out of a flock of 400,000 supplied the milk for 7,150,000 lbs. of cheese. The fertile pasturage of these animals is an immense plain, 8 or 10 leagues across. In the evening, after the return of the sheep from the pastures, they are allowed to rest for an hour before being milked, after which they will yield the milk more readily, and are milked as rapidly as possible. From May 1 to the middle of July the yield of milk is the largest, and each animal gives nearly a pint.

The Larzac breed of sheep, from the milk of which the cheese is made, have large udders, made so by beating them with the hand as soon as the milk ceases to flow. The evening's milk is heated almost to boiling and set aside. In the morning it is skimmed, heated to 98°, and mixed with the morning's milk for coagulation. After the curd has been divided by stirring with a paddle and the whey drawn off, it is kneaded with the hands and pressed in layers into moulds with perforated bottoms, and usually a thin layer of mouldy bread made of summer and winter barley, sour dough and vinegar, is put between the layers of curd to hasten the ripening of the cheese by supplying the germs of the green mould peculiar to cheese. The curd remains under pressure for three or four days, after which the cheeses are wrapped in linen and put to dry. After drying for three or four days they are taken to the village of Roquefort, where the ripening is completed in a peculiar manner.

The village is situated in a deep, narrow gorge, with high precipitous walls of limestone rock overhanging. These walls are full of caves and fissures, from which currents of cold air issue at a temperature, in the hottest weather, of from 41° to 44°. The air currents flow from south to north, and are believed to yield the best cheese. The proprietors of the vaults purchase cheeses at all seasons from the shepherds. They are carefully examined and classified. Salt is then sprinkled over them, and they are piled up for two or three days; then the piles are taken down, the salt and brine rubbed in, and they are piled up again. After a week in the vaults, they are scraped and pared, pricked through with needles, driven by machinery, to accelerate the moulding, and again kept in piles for fifteen days, or until they become dry and firm in texture, and become covered with a white mould, with filaments sometimes five or six inches long. Its succulence and thickness indicate the quality of the cheese.

New Agricultural Inventions.

Mr. Slaughter G. Major, of Haynesville, Mo., has patented an improved device for use in milking cows, which is convenient and may be easily and quickly applied, and will not injure the cow.

Mr. William J. Klaunig, of Richmond, Va., has patented an improved Mower, having a wave wheel of peculiar form which imparts to the knives a scythe-like cutting action, that prevents the dropping of the grain from the ears, which is likely to occur in the ordinary machine from the rapidly reciprocating motion of the knives, which motion shakes out the grain, and compels, therefore, the cutting of the grain before it has become entirely ripe.

PARAFFINE AS A LUBRICANT.—A correspondent of the *Railroad Gazette* announces that the Erie railway has reduced its oiling expenses from \$5,000 to \$1,000 a year by using paraffine on passenger car journals, and has reduced the number of hot journals from 535 to 332. It is now used during the winter months, without the addition of any other oil, but it is found that in summer it becomes so limpid that it is hard to keep it in the axle boxes. During the summer months it is therefore mixed with some other lubricant to give it more "body."

ERRATUM.—In our issue of January 18, p. 35, in the article on the Columbia bicycle, the description should read: "The front wheel bearings are conical and well hardened, and fitted with coned fastenings. The India-rubber is 1 inch on the front and $\frac{3}{4}$ inch diameter on the back wheel."

Accuracy a Path to Wealth.

In this age of guesswork it is refreshing to read an article on the following, contributed to the *Methodist* by John D. Knox, of Topeka, Kansas, on the importance of exactness. The author commences with the importance of accuracy in the value of testimony, all depending on its exactness, and proceeds to say: The professed end of logic is to teach men to think, to judge and reason with precision and accuracy. S. Martin asks: "What makes the scholar? Exactness. What is most likely to secure success in the learned professions? Exactness. What raises men of various callings to the highest position attainable by persons in their occupations? Exactness. What makes a man's word pass current as gold? His known exactness. What, above all things, is essential in the laboratory? Exactness."

Mr. Martin is right. Exactness, accuracy, perfection in all the work you undertake will bring you a sure reward. And the record of a noted man is found in these words: "He became an honorable man, successful merchant, and bank president." His splendid career commenced in blacking a pair of boots well when a boy; and he continued "doing well" all through life, whether blacking boots or managing finance. What he did he did accurately, and, of course, it did not have to be done over or improved or mended, but always gave satisfaction and secured commendation.

President Tuttle, on "How to Get the Best Place," gives us this instance: "I saw a young man in the office of a Western railway superintendent. He was occupying a position that four hundred boys in the city would have wished to get. It was honorable and 'it paid well,' besides being in the line of promotion. How did he get it? Not by having a rich father, for he was the son of a laborer. The secret was, his beautiful accuracy. He began as an errand boy, and did his work accurately. His leisure time he used in perfecting his writing and arithmetic. After a while he learned to telegraph. At each step his employer commended his accuracy, and relied on what he did because he was sure it was just right."

And it is thus with every occupation. The accurate boy is the favored one. Those who employ men do not wish to be on the constant lookout, as though they were rogues or fools. If a carpenter must stand at his journeyman's elbow to be sure his work is right, or if a cashier must run over his book-keeper's columns, he might as well do the work himself as to employ another one to do it in that way; and it is very certain that the employer will get rid of such an inaccurate workman as soon as possible.

I knew such a young man. He had a good chance to do well, but he was so inaccurate and unreliable that people were afraid to trust him. If he wrote a deed or mortgage or a contract, he was sure to leave out something or put in something to make it an imperfect paper. He was a lawyer without business, because he lacked the noble quality of accuracy.

Just across the street from him was another young lawyer, who was proverbial for accuracy. He was famous for searching titles, and when he wrote out the history of a title to a piece of property, it was taken for granted as just so. His aim was absolute accuracy in every thing. If he copied a conveyance or cited a legal authority or made a statement, he aimed to do it exactly. The consequence is, he is having a valuable practice at the bar and is universally esteemed.

"But," says some boy, "when I become a man that is the way I shall do. I mean to be very accurate." Perhaps so; I could tell better if I knew just how you do your work now. There are several ways of getting a lesson. One is to get it "tolerably well," which does not cost much labor; the other is to get it faultlessly well, which costs a great deal of labor. A boy can get a general idea of his lesson "in a jiffy;" but to get it accurately is very hard, and requires both time and industry. If you, my boy, to-day are getting your lesson in the slipshod way, you will grow up a slipshod man; but if to-day your habit is to get every lesson with perfect accuracy, I will warrant you will do that way when you become a man. How is it?

Millions of persons in the world are clamoring for work, and work is abundant; but they are careless, inaccurate, unreliable, untrustworthy. Shake off your stupidity, idle one; get wide awake and do your work well. Accurate, perfect, for even a dot or point may shelter you or turn you out of doors.

To illustrate the importance of accuracy and careful, honest work, take this instance of loss by bad penmanship: "A decision was rendered by Judge Van Brunt, of New York, which may be of interest to those who are careless in preparing manuscript, and think anything in the guise of handwriting will do that can either be deciphered or guessed at. It was a suit brought to recover damages from a telegraph company for errors committed in transmitting a message, by which the party suing suffered pecuniary loss. On the trial the original message, as written and handed to the operator,

was offered in evidence, and was so illegibly written that no two persons could agree from the marks submitted what it actually did contain. Whereupon the judge instructed the jury that if people wrote their dispatches in such a hand that the contents are uncertain, they have no right to recover damages from the dispatcher because he failed to read it correctly, and that if damages do result from such causes, the sender and not the company should bear the loss. This was good common sense, which is the essence of common law."

Some persons take no care at all in anything they do, forgetting that the interests of others, as well as themselves, depend upon the character of their work. It is not only a matter of cents and dollars, but it is a matter of morals.

DESIGNS FOR VASES.

The engraving on this page shows three elegant designs for vases in metal or ceramics. These designs are from the firm of Villeroy, of Mettlach.

Astronomical Notes.

OBSERVATORY OF VASSAR COLLEGE.

The computations in the following notes are by students of Vassar College. Although only approximate, they will enable the ordinary observer to find the planets.

M. M.

Positions of Planets for February, 1879.

Mercury.

February 1, Mercury rises at 6h. 18m. A.M., and sets at 3h. 25m. P.M. February 28, Mercury rises at 6h. 43m. A.M., and sets at 5h. 24m. P.M.

Mercury is far south in declination, and if seen at all, it will be during the first few days of February, some degrees south of the point of sunrise.

Venus.

February 1, Venus rises at 8h. 2m. A.M., and sets at 6h. 18m. P.M. February 28, Venus rises at 7h. 33m. A.M., and sets at 7h. 26m. P.M.

Venus will be seen after sunset, and will set farther and farther north of the point of sunset, through the month. February 22, the moon and Venus will be in conjunction.



DESIGNS FOR VASES IN METAL OR CERAMIC.

Mars.

February 1, Mars rises at 4h. 35m. A.M., and sets at 1h. 31m. P.M. February 28, Mars rises at 4h. 10m. A.M., and sets at 1h. 11m. P.M.

Mars will be seen only in the early morning, it is far south in declination, among the small stars of Sagittarius

Jupiter.

Jupiter sets in the early part of the month soon after the sun, and in the latter part before the sun; it will probably not be observed at all.

Saturn.

Although we are more distant from Saturn than in January, the planet can be seen in the February evenings. February 1 Saturn sets at 9h. 7m. P.M., and on the 28th, at 7h. 36m. P.M. The planet passes the meridian in daylight, and the smaller moons are more and more difficult to be seen. The ring of Saturn is so tipped relatively to the earth, as to be seen nearly edgewise, and to extend as a line across and beyond the planet's disk. On the evening of January 10, Titan was seen (in the large telescope of Vassar College) on the west of Saturn. Rhea, which is much smaller than Titan, and shines with a bluish light, on the east, while Dione and Enceladus could just be seen as tiny points of light above and below the extreme eastern point of the ring. January 13, four of the small moons clustered in a group about the western extension of the ring, while Titan and Enceladus were on the east.

Saturn can be found, February 23, by its nearness to the crescent moon.

Uranus.

Uranus is the only planet which is well situated for observation in February. It is sometimes seen with the eye, and

a small telescope will show a disk, and thereby enable one to distinguish it from a star. Uranus rises on February 1 at 6h. 56m. P.M., and sets at 8h. 16m. A.M. of the next day. On February 28, Uranus rises at 5 P.M., and sets at 6h. 24m. A.M. of the next day.

Uranus will be in conjunction with the moon (according to the American Ephemeris) at 11h. 40m., Washington time, on February 7; the planet will be a few degrees above the moon.

Uranus can also be found by its nearness to the star Rho Leonis.

Neptune.

Neptune cannot be seen except by very powerful telescopes. It sets February 1 a little after midnight, and on February 28 as early as 10h. 35m. P.M.

Care of the Eyes.

From the great demand for the eight numbers of the SUPPLEMENT to the SCIENTIFIC AMERICAN, in which appeared a series of articles on the preservation of the eyesight, it is evidently a subject in which most persons are more than ordinarily interested. As a writer on the care of the eyes, in an English paper, recently said: "All are anxious to do this, but few know how effectually to do so, and many never think of the matter till failing eyesight warns them that it is absolutely necessary. By the latter," says the same writer, "the following suggestions will be read with interest:

"The sight in most persons begins to fail from forty to fifty years of age, as is evidenced by an instinctive preference for large print; a seat near the window for reading is selected; there is an effort to place the paper at a convenient distance from the eye, or to turn it so as to get a particular reflection of the light; next the finger begins to be placed under the line read, and there is a winking of the eye as if to clear it, or a looking away at some distant object to rest it; or the fingers are pressed over the closed lids in the direction of the nose, to remove the tears caused by straining.

"Favor the failing sight as much as possible. Looking into a bright fire, especially a coal fire, is very injurious to the eyes. Looking at molten iron will soon destroy the sight; reading in the twilight is injurious to the eyes, as they are obliged to make great exertion. Reading or sewing with a side light injures the eyes, as both eyes should be exposed

to an equal degree of light. The reason is, the sympathy between the eyes is so great that if the pupil of one is dilated by being kept partially in the shade, the one that is most exposed cannot contract itself sufficiently for protection, and will ultimately be injured. Those who wish to preserve their sight should observe the following rules, and preserve their general health by correct habit:

"1st. By sitting in such a position as will allow the light to fall obliquely over the shoulder upon the page or sewing.

"2d. By not using the eyes for such purposes by any artificial light.

"3d. By avoiding the special use of the eyes in the morning before breakfast.

"4th. By resting them for a half minute or so while reading or sewing or looking at small objects; and by looking at things at a distance, or up to the sky; relief is immediately felt by so doing.

"5th. Never pick any collected matter from the eyelashes or corners of the eyes with the finger-nails; rather moisten it with the saliva and rub it away with the ball of the finger.

"6th. Frequently pass the ball of the finger over the closed eyelids toward the nose; this carries off an excess of water into the nose itself by means of the little canal which leads into the nostril from each inner corner of the eye, this canal having a tendency to close up in consequence of the slight inflammation which attends weakness of eyes.

"7th. Keep the feet always dry and warm, so as to draw any excess of blood from the other end of the body.

8th. Use eyeglasses at first carried in the vest pocket attached to a guard, for they are instantly adjusted to the eye with very little trouble, whereas, if common spectacles are used such a process is required to get them ready that to save trouble the eyes are often strained to answer a purpose.

"9th. Wash the eyes abundantly every morning. If cold water is used let it be flapped against the closed eyes with the fingers, not striking hard against the balls of the eyes.

"10th. The moment the eyes feel tired, the very moment you are conscious of an effort to read or sew, lay aside the book or needle, and take a walk for an hour, or employ yourself in some active exercise not requiring the close use of the eyes."*

*The following are the numbers of the SUPPLEMENT containing the series of articles on preserving the eyesight: 125, 127, 130, 136, 139, 142, 147, 147. They will be mailed from this office on receipt of 80 cents.

Notes on Electrical Lighting.

The latest electric lamp in the field is that of Mr. J. B. Fuller, who claims that it has been in practical use for a year or more. The first public exhibition of the lamp was made a short time since at the office of the New York Electric Light Company, in Mercer street. Its power was said to be equal to 2,400 candles; the electricity being furnished by a generator patented by Mr. Fuller. This lamp uses carbon points. Mr. Fuller claims to have invented also a platinum lamp of 20 candle power which solves the problem of domestic lighting.

The carbon lamp, Mr. Fuller says, has been in use a year in the factory where his apparatus is made in Brooklyn. The cost of the generator and lamp was \$290, and they are both as good to-day as when they were first used. The power used was so little that no charge was made for it by the parties furnishing the steam power for the shop. The carbon points cost 4 cents per hour. The shop lighted is 100 by 40 feet, and the light furnished is much better than gaslight. Roughly estimated, the first year's saving on the gas that would be required in the shop is more than enough to pay for the entire apparatus for producing the electric light. Of course that saving would not be effected where an engine and boiler would be required for the sole purpose of furnishing the motive power to the electric generator.

Mr. J. M. Stearnes, Jr., of Brooklyn, points out a novel source of danger possible with the electric light, namely, its effect upon the nervous system. He says:

"The very high penetrating power of light waves from incandescent metal or carbon heated by electricity is well known. It is so high, indeed, that the shadows cast by the light are blacker than Erebus, indicating an immense absorption of force by the intervening objects, and to a large extent destroying their reflection and diffusion, as is the case with lights of lesser tension. A reflector used with an electric or calcium light does not produce anything like a corresponding effect as when used with a common gas flame, as persons familiar with calcium lights well know. And it follows, therefore, that the black shadows of the electric flame must be due to the absorption of light waves. Now in the light of an electric arc or incandescent lamp, one is to be subjected to a very powerful stimulant from the mere obstruction which his body affords. Our eyes cannot bear it at all, and there is no reason to doubt that every nervous tissue will feel its use. We have already in this climate enough of nervous stimulation, and a fearful catalogue of nervous diseases, arising from too much force."

Mr. Stockley, the engineer of the Brush Company, does not claim that more than 18 of that kind of lights have been maintained in one circuit with one machine, the lights being each equal to 2,000 candles. How many could be maintained with more machines is not yet known. Perhaps no more. Sawyer & Man, who have the continuous carbon, claim that they have burned 17 lamps with the power of 5 gas burners each with one machine, but say they can maintain 50. Edison claimed originally that he could maintain some such absurd number as 10,000 with a 500 horse power engine, but now claims only to be able to keep 480 lights going with an 80 horse power engine. But none of the inventors have made any extended experiments whatever. Their claims are all guess work.

Professor Morton recently exhibited in Hoboken the Sugg gas burner from London, a burner which gives a very perfect combustion of gas. A 50 foot gas burner is found to give a light equal to that of 300 candles. The burner has been tried by many of the engineers of the gas companies of the city here, and they find that a 40 foot burner gives a light equal to that of 250 candles, and a 50 foot burner one equal to that of 300 candles. If, now, this same stream of gas be supplied to ten 5 foot Sugg burners, each light would be found to be equal only to 15 candles, the total not exceeding 150 candles, as against 300. If the gas was supplied to 50 burners, little half blue flames would be created, which would hardly be lights at all. The explanation is, that in the large lights the particles of carbon are simply in a state of more intense incandescence by reason of the greater heat. The lower the heat, the less intense the incandescence, and the more feeble the light. This fact of the loss of light by the subdivision of a current of gas is now fully established. It shows that the loss of light by subdivision in electricity is not at all a unique circumstance. Intensity is lost both in gas lights and electric lights, and for exactly the same reason.

M. Carré, of Paris, finds it necessary to extend his establishment for the manufacture of carbons for the electric light. There are more than 6,500 feet of carbons per day turned out at his works at present.

Now that electric lighting successes have caused so many old devices to be dressed up as new inventions, the *Engineer* remarks that it is difficult to understand why some attempt has not been made to improve upon the idea of Allan, and to produce electrodes in the form of a screw. It quotes this reference to Allan's lamp from the *Mechanics' Magazine* of 1852: "The two electrodes are placed perpendicularly to one another, and in this relation are made to rotate by a simple clock-work movement. The result is that as the edge of the spiral is in the course of being destroyed by the action of the current, and the distance between the two thereby increased, it is always regaining the proper position by the rotation of the electrodes producing fresh points for action. In this manner a constant distance or relation is preserved, and hence a constant, steady light, the grand desideratum, the duration of which will depend only upon the length of the thread of the screw."

A. M. Bailey, of Paris, has invented an electric spark pen which possesses some points of interest. If a sheet of thin paper is attached to a plate of copper or zinc, it is stated that an engraving may be made with extraordinary facility by means of this pen. If one of the poles of a Ruhmkorff machine is attached to the plate and the other to the upper end of the pen, the current will run through, and in drawing the paper is perforated. When the drawing is finished, ink is laid on with an ordinary roller and the greasy fluid penetrates through the holes. The plate is then plunged in water, which detaches the paper, and it is ready for immersion in the acid. The advantage claimed for this method is that the artist does all parts of his work and has no more trouble than if he were working with an ordinary pencil. He can even work in a dark room without any other light than the glare from the induction spark.

Mr. W. H. Preece, electrician to the British Post Office, says that he has sought in vain, at Paris and elsewhere, for an electric light which should meet the following three conditions, namely: (1) That the light be absolutely steady; (2) that it be brilliant, giving a light of 1,000 candles, or more; (3) that it be durable. Of all the lights, the only one he had seen which came up to his standard of brilliancy was the Serrin; the only one which came up to his criterion of steadiness was the Werdermann; and the only one sufficiently durable was the Wallace, by which he meant one which would last all night, and nights in England sometimes lasted eighteen hours. But there were several which came pretty near these criteria.

The Papaw Tree, and its Digestive Juice.

The papaw or papaya (*Carica papaya*) is a small tree, a native of tropical America, and cultivated particularly on the wooded slopes of the Andes. It seldom attains a height of over twenty feet; and its trunk, one foot in diameter at the base, gradually tapers upward without branching, and bears at its summit a crown of long-petioled leaves deeply cut into seven irregularly gashed lobes. The male and female flowers are borne on separate trees, and hence the tree receives from the natives the name "papaya," or "mamai," according to such views as each individual may entertain as to the pre-eminence of the sex.

The ripe fruit of the papaw is a melon-shaped berry about ten inches long and half as wide, with a thick, fleshy rind of an orange yellow color, which is sometimes eaten raw with sugar and pepper, but oftener cooked with sugar and lemon juice. The most interesting and important property attributed to the fruit, however, is the power of its juice to rapidly render hard flesh tender; and what is more remarkable still, newly killed meat, merely suspended among the branches of the tree, or wrapped up in its leaves, becomes tender in a wonderfully short time; and this fact, according to Professor Orton, is taken advantage of by Brazilian butchers to make their very toughest meat saleable.

As far back as the year 1750, Griffith Hughes says of the juice of the papaw fruit, in his "History of Barbadoes:" "This juice is of so penetrating a nature that if the unripe peeled fruit be boiled with the toughest old salted meat, it quickly makes it soft and tender, and if pigs be fed with the fruit, especially unripe, the thin mucous matter which coats the inside of the intestines is attacked, and if the food be not changed, is completely destroyed."

According to Browne, meat becomes tender after being washed with water to which the juice of *Carica papaya* has been added, and if left in such water ten minutes, it will fall from the spit while roasting, or separate into shreds while boiling. According to Karsten, the use of the papaw juice when boiling meat is very general in Quito, but in Venezuela and Costa Rica the practice is unknown.

Some further experiments were made by Roy, who, by making an incision in a single fruit, obtained 28-39 c.c. of the milky juice, which, after evaporating to dryness and again diluting with water, had a powerful action upon flesh, albumen, and gluten, while starch remained unaltered by it. Very recently Herr Wittmack has investigated the subject, and an account of his researches and experiments formed the subject of a paper communicated to the Berlin Natural History Society at one of its late sessions. The author obtained, after several incisions of half or unripe fruit, 1-195 grain of a white milky juice of the consistency of cream; the odor and flavor of this recalled that of petroleum or of vulcanized rubber. A portion of the juice was dissolved in three times its weight of water, and this was placed with 10 grammes of quite fresh lean beef in one piece in distilled water, and boiled for five minutes. Below the boiling point the meat fell into several pieces, and at the close of the experiment it had separated into coarse shreds. In the control experiments, made without the papaw juice, the boiled meat was visibly harder. Hard boiled albumen, digested with a little juice at a temperature of 20° C., could, after twenty-four hours, be easily broken up with a glass rod. Fifty grammes of beef in one piece, enveloped in a leaf of the papaw during twenty-four hours, at a temperature of 15° C., after a short boiling became perfectly tender; a similar piece wrapped in papaw and heated in the same manner, remained quite hard. Some comparative experiments were also made with pepsin, and the following conclusions are arrived at by the author:

(1) The milky juice of *Carica papaya* is (or contains) a ferment which has an extraordinary energetic action upon nitrogenous substances; (2) it differs from pepsin in being active without the addition of a free acid, and, further, it operates at a higher temperature (60° to 65° C.) and in a shorter time (five minutes at most); (3) the filtered juice

differs chemically from pepsin in that it gives no precipitate on boiling, and further that it is precipitated by mercuric chloride, iodine, and all mineral acids; (4) it resembles pepsin in being precipitated by neutral acetate of lead, and not giving a precipitate with sulphate of copper and perchloride of iron. An analysis of the juice of the papaw made in former years by Vauquelin, showed it to contain *fibrine*—a substance which at one time was supposed to be confined to the animal kingdom, but was known to exist in several vegetables.

The Color of Human Hair.

In the current number of the *Journal of the Anthropological Institute* appears a paper by Mr. H. C. Sorby, describing some researches in which he has endeavored to isolate the pigments of the hair, and to subject them to chemical and spectroscopic scrutiny. Hitherto little has been really known respecting the causes of the difference in color, and the distinctive characters of the various capillary pigments. Mr. Sorby concludes that hair is a colorless, horny substance, tinted in different specimens by three, or possibly four, distinct pigmentary bodies. Ordinary solvents, such as water and alcohol, have no action on the pigments, since these are protected by the horny matter. Sulphuric acid, more or less dilute, appears to be the best medium for separating the coloring principles. By this means the author obtains from different kinds of human hair a reddish, a yellow, and a black pigment. It is possible that the red, which is an unstable body, may pass into the yellow by a process of oxidation. Very red hair is characterized by the presence of the red constituent, unmodified by other pigments; dark red hair contains also some of the black pigmentary matter; golden hair has less of the red and more of the yellow principle; in sandy-brown hair the black and red constituents are associated with a large proportion of yellow coloring matter; in dark brown hair the black pigment increases at the expense of the others; while in black hair this dark coloring material completely overpowers the associated pigments.

It is a notable fact that Mr. Sorby found in some very black hair of a negro just as large a proportion of red pigment as in a very red hair of European origin. We may, therefore, safely conclude that if this negro had failed to develop the black pigment his hair would have been, not white, but as bright red as that of any red-haired European.

Perverted Ingenuity.

The *Boston Journal of Chemistry* thinks there is a good deal of perverted ingenuity in the world besides that which is directly criminal or mischievous in its purpose. It is indirectly criminal because it is a waste of labor and skill, sometimes even of health and life, in doing a difficult but utterly useless thing merely to show that it can be done, or for the sake of the notoriety which the achievement is likely to gain. Every museum has specimens of this misapplied toil and ingenuity—miniature models, carvings, and the like, which are marvels of delicacy and elaboration, but of no real artistic merit and of no possible practical value. If a solitary prisoner in his cell beguiles the weary years of his confinement with such patient labor, for the lack of other employment or diversion, we pardon while we pity him. We may even forgive the ubiquitous old woman who displays at the country fair the quilt of fourteen thousand and odd pieces of patchwork, as fearful in design and coloring as it is complicated in structure; for it may never have occurred to the worthy dame, and no Christian friend may have reminded her, that the time and work spent upon it would have served to knit some hundreds of pairs of hose for the barefoot poor, and have counted more to her credit on a certain long-running ledger than the coveted "premium" or "honorable mention" at the village show. But when sensible and cultivated people deliberately combine in planning and carrying out some silly performance of this kind, they ought not to receive the eulogies of the public press or the honors of international exhibitions.

These criticisms have been suggested by the accounts in foreign journals of a book which we are told was put into the market at the close of the French Exhibition. Its claim to distinction is the fact that it is the smallest book in the world. It is a "128mo" edition of Dante's "Divina Commedia," printed at Padua last year; a volume of 500 pages, measuring 5 centimeters (a trifle less than 2 inches) high, and 3½ (less than 1½ inch) broad. Only a thousand copies have been printed, and the type has been destroyed. It can be read only with a powerful magnifying glass.

Verily a noble example of "the art preservative of all arts!" Blindness and ophthalmia for the workmen engaged upon it, and the result a volume which nobody can read without a microscope, and which nobody will care to buy except the insatiable book hunter or curiosity monger! Is not this a worthy tribute to the great Florentine poet in this nineteenth century? Could he with prophetic vision have anticipated it, would he not have dedicated a warm corner in his "Inferno" to the special accommodation of Signor Gnocchi and Cantù, or whoever else is responsible for this infinitesimal monument of perverted ingenuity?

A Costly Telescope.

M. Camille Flammarion, of Paris, has recently published a number of articles to prove that the moon is inhabited, and is now organizing a committee to collect the necessary funds to construct a refracting telescope of sufficient power to see them. He calculates the cost of the instrument at one million francs.

TO INVENTORS.

An experience of more than thirty years, and the preparation of not less than one hundred thousand applications for patents at home and abroad, enable us to understand the laws and practice on both continents, and to possess unequalled facilities for procuring patents everywhere. In addition to our facilities for preparing drawings and specifications quickly, the applicant can rest assured that his case will be filed in the Patent Office without delay. Every application, in which the fees have been paid, is sent complete—including the model—to the Patent Office the same day the papers are signed at our office, or received by mail, so there is no delay in filing the case, a complaint we often hear from other sources. Another advantage to the inventor in securing his patent through the Scientific American Patent Agency, it insures a special notice of the invention in the SCIENTIFIC AMERICAN, which publication often opens negotiations for the sale of the patent or manufacture of the article. A synopsis of the patent laws in foreign countries may be found on another page, and persons contemplating the securing of patents abroad are invited to write to this office for prices, which have been reduced in accordance with the times, and our perfected facilities for conducting the business. Address MUNN & CO., office SCIENTIFIC AMERICAN.

Business and Personal.

The Charge for Insertion under this head is One Dollar a line for each insertion; about eight words to a line. Advertisements must be received at publication office as early as Thursday morning to appear in next issue.

Valves and Hydrants, warranted to give perfect satisfaction. Chapman Valve Manuf. Co., Boston, Mass.

Nickel Plating.—Wenzel's Patent Perforated Carbon Box Anode for holding Grain Nickel.

H. Prentiss & Company, 14 Dey St., N. Y., Manufs. Taps, Dies, Screw Plates, Reamers, etc. Send for list.

Needle Pointed Iron, Brass, and Steel Wire for all purposes. W. Crabb, Newark, N. J.

Assays of Ores, Analyses of Minerals, Waters, Commercial Articles, etc. Technical formulæ and processes. Fuller & Stillman, 40 & 42 Broadway, N. Y.

Nickel Platers and Manufacturers use Bunnell's New Nickel Solution, warranted to be no infringement upon any patent. Its low cost, easy, rapid action, white and beautiful deposit on iron, brass, copper, etc., commend it as the best working solution yet produced. Materials for solution, which is easily made, together with prices, etc., furnished upon application. J. H. Bunnell, Electrician, 112 Liberty St., New York.

Hydraulic Elevators for private houses, hotels, and public buildings. Burdon Iron Works, Brooklyn, N. Y.

Bolt Forging Machine & Power Hammers a specialty. Send for circulars. Forsaith & Co., Manchester, N. H.

Blake's Belt Studs; strongest, cheapest, and best fastening for Leather or Rubber Belts. Greene, Tweed & Co., New York.

Ophir Mine, Gold Hill, Nevada, Jan. 4, 1879: I have applied H. W. Johns Asbestos Double Air Chamber Covering to our pipes, and it gives perfect satisfaction. I consider it the very best covering introduced on the "Comstock," and I can apply it at less than half the cost of cements or any other material. Yours truly, M. C. Foot, Chief Engineer. Ophir Mining Co., Virginia, Nev., Jan. 6, 1879: Having used these goods, I fully concur in Mr. Foot's opinion. James Brown, Chief Engineer. The genuine Asbestos materials are manufactured only by the H. W. Johns Manufacturing Company, 87 Maiden Lane, N. Y. Beware of imitations.

38 in. Swing Lathe, 12 foot bed, triple geared, compound rest, cross feed, \$400. Will exchange for Horizontal Boring Mill. Stiles & Parker Press Company, Middletown, Conn.

Inventors of Small Articles suitable for Hardware Trade, seeking a market, please address Courtenay & Trull, No. 17 Dey St., New York.

Calvin Carr's Cornice Machines. Cleveland, O. Best and cheapest.

Eagle Anvils, 9 cents per pound. Fully warranted.

Wanted.—A good draughtsman, boiler maker, smith, and hammerman. Apply to Noble Bros. & Co., Rome, Ga.

Walrus Leather, Walrus Wheels; all kinds of Polishing Supplies, in quantities to suit. Greene, Tweed & Co., New York.

For Sale Cheap.—Second-hand 8 foot Boring and Turning Mill, Lathes, Planers, Drills, Bolt Cutters, etc. Circulars. D. Frisbie & Co., New Haven, Conn.

A Proprietary Medicine Business.—Its right, title, trade marks, etc.; five medicines established over 30 years; well known curatives; well authenticated; will be sold cheap. For particulars address Medico, care Druggists Circular, 36 Beekman St., New York.

The only economical and practical Gas Engine in the market is the new "Otto" Silent, built by Schleicher, Schumm & Co., Philadelphia, Pa. Send for circular.

For Solid Wrought Iron Beams, etc., see advertisement. Address Union Iron Mills, Pittsburgh, Pa., for lithograph, etc.

Presses, Dies, and Tools for working Sheet Metal, etc. Fruit & other can tools. Bliss & Williams, B'klyn, N. Y.

Bl'k's, Mech's, Ma'fs., address Box 73, Willimantic, Ct.

For Sale.—Brown & Sharp Universal Milling Machine; Bement Profiling Machine; first-class 2d hand Machine Tools. E. P. Bullard, 14 Dey St., N. Y.

Send for circulars of Indestructible Boot and Shoe Soles to H. C. Goodrich, 40 Hoyne Ave., Chicago, Ill.

Nickel Plating.—A white deposit guaranteed by using our material. Condit, Hanson & Van Winkle, Newark, N. J.

1,000 2d hand machines for sale. Send stamp for descriptive price list. Forsaith & Co., Manchester, N. H.

Galland & Co.'s improved Hydraulic Elevators. Office 26 Broadway, N. Y., (Evening Post Building, room 22.)

Brush Electric Light.—20 lights from one machine. Latest & best light. Telegraph Supply Co., Cleveland, O.

J. C. Hoadley, Consulting Engineer and Mechanical and Scientific Expert, Lawrence, Mass.

The Lathes, Planers, Drills, and other Tools, new and second-hand, of the Wood & Light Machine Company, Worcester, are to be sold out very low by the George Place Machinery Agency, 121 Chambers St., New York.

Solid Emery Vulcanite Wheels.—The Solid Original Emery Wheel—other kinds imitations and inferior. Caution.—Our name is stamped in full on all our best Standard Belting, Packing, and Hose. Buy that only. The best is the cheapest. New York Belting and Packing Company, 37 and 38 Park Row, N. Y.

Bevins & Co.'s Hydraulic Elevator. Great power, simplicity, safety, economy, durability. 94 Liberty St. N. Y.

For Town and Village use, comb'd Hand Fire Engine & Hose Carriage, \$350. Forsaith & Co., Manchester, N. H.

Hydraulic Presses and Jacks, new and second hand. Lathes and Machinery for Polishing and Buffing Metals. E. Lyon & Co., 470 Grand St., N. Y.

Inventors' Models. John Ruthven, Cincinnati, O. Sheet Metal Presses, Ferracute Co., Bridgeton, N. J.

Pulverizing Mills for all hard substances and grinding purposes. Walker Bros. & Co., 23d & Wood St., Phila., Pa.

The Lambertville Iron Works, Lambertville, N. J., build superior Engines and Boilers at bottom prices.

Band Saws, \$100; Scroll Saws, \$75; Planers, \$150; Universal Wood Workers and Hand Planers, \$150, and upwards. Bentel, Margedant & Co., Hamilton, Ohio.

Diamond Engineer, J. Dickinson, 64 Nassau St., N. Y. Machine Cut Brass Gear Wheels for Models, etc. (new list). Models, experimental work, and machine work generally. D. Gilbert & Son, 212 Chester St., Phila., Pa.

The best Friction Clutch Pulley and Friction Hoisting Machinery in the world. D. Frisbie & Co., N. Haven, Ct.

Texas Machinery Depot for any kind of machinery or special hardware. P. H. Gerhard, Austin, Texas.

The only Engine in the market attached to boiler having cold bearings. F. F. & A. B. Landis, Lancaster, Pa. Improved Meat Cutter. Capacity 600 lbs. an hour. Circular and price list, J. W. McFarland & Co., Alliance, O.

Fine Taps and Dies for Jewelers, Dentists, and Machinists, in cases. Pratt & Whitney Co., Hartford, Conn.

Improved Steel Castings; stiff and durable; as soft and easily worked as wrought iron; tensile strength not less than 65,000 lbs. to sq. in. Circulars free. Pittsburg Steel Casting Company, Pittsburg, Pa.

Dead Pulleys that stop the running of loose pulleys and their belts, controlled from any point. Send for catalogue. Taper Sleeve Pulley Works, Erie, Pa.

Correct thing for Holidays, Whist and Dinner Parties, is the Vanity Fair Cigarettes, with your monogram.

Vertical & Yacht Engines. N. W. Twiss, New Haven, Ct.

Partner Wanted.—See advertisement on inside page.

Best results obtained from Success Turbine Water Wheel. References given. S. M. Smith, York, Pa.

Neophography—The best and easiest short hand. Only the alphabet to be mastered. 50 cents. Harroun & Bierstadt, 58 Reade Street, New York.



(1) W. C. M., J. B. C., and E. F., who ask for books, should address the publishers who advertise in the SCIENTIFIC AMERICAN, for catalogues.

(2) H. R. R. has an engine of the following dimensions: 10 inches cylinder, 18 inches stroke, piston rod 2 inches, crank pin 2 inches, shaft 4 1/2 inches diameter, 6 feet long, fly wheel weighs 800 lbs., rim 14 inches wide x 3/4 thick; engine makes 130 revolutions per minute, and asks what sized fly wheel he may use instead of the present one. A. A wheel of three times the diameter and double the weight of the present one may be used.

(3) E. E. H. asks: 1. What kind of pump runs with the least power? A. Pumps made without packing generally give the highest efficiency. 2. Will two pumps of the same size pump enough water to fill a pipe of the size of one of the pump barrels? A. They can be made to do so.

(4) F. W.—For receipts for tempering mill picks, see p. 219 (27) vol. 39.

(5) P. A. D. asks: 1. Why is the outside rail on a curve on the railroad the highest? A. To counteract the centrifugal force of the train as it passes the curve. 2. Do the outside wheels of a railroad car slide any in going around a curve? A. Generally, the inside wheel slips.

(6) C. W. G. asks: Is it possible to obtain CO from K₂FeC₄N₆+6H₂SO₄ without adding the 6 parts H₂O? A. Yes, but the decomposition is not complete. The gas is usually prepared from the crystallized salt (K₂FeC₄+3H₂O) with eight or ten times its weight of strong oil of vitriol. If the acid is diluted with water, hydrocyanic acid is given off with or instead of carbonous oxide, thus: 2K₂FeC₄N₆+6H₂SO₄+XH₂O=FeK₂FeC₄+6HKSO₄+6HCN+XH₂O.

(7) R. H. E. writes: I have read that 33-1 cubic feet of steam expended per minute was equal to an actual horse power. Is this so? A. The power of an engine cannot be estimated by the capacity of its cylinder, nor by the number of cubic feet of steam used in a given time. These are only factors of the calculation.

(8) "Subscriber" writes: A friend of mine says that when a river is rising it will either rise till 12 o'clock at noon or 12 o'clock at midnight. I claim that this is not true, excepting when there is a tide which would change at that time. A. We agree with you.

(9) F. H. asks: What causes hammering in steam pipes, the steam pressure being about the same at all times and the pipes are constantly fed with live steam? A. It is probably due to defective circulation.

(10) X. asks: What is gained by forcing cold feed water into the steam room of a boiler instead of pumping it into the water space in the usual way? A. There is no gain of efficiency, and, generally, no gain of any kind, although, in some special cases, the circulation might possibly be promoted by this method of feeding.

(11) W. A. P. writes: I have in my house two gas lights in different rooms, both 18 inches from the ceiling, one has a globe and the other has not; the one without the globe blacks or spots the plastering, the one with the globe does not; why is it? A. The globe probably insures more perfect combustion by directing a uniform current of air over the flame.

(12) E. W. asks for directions for making a Leyden jar. A. Take an ordinary candy jar one or two quart, according to size required, coat it inside and outside for about three fourths the distance from the bottom toward the top with thin tin foil. The jar is coated with thick shellac varnish, and the foil is immediately pressed on. The jar should have a wooden cover, through the center of which passes a rod having at its lower end a chain that touches the tin foil at the bottom of the jar, and at its upper end a brass knob.

(13) R. D. McN. asks what will bring out the color on parchment. I have some deeds that got wet, and have faded. A. Moisten the ink with a strong aqueous solution of tannic acid.

(14) R. P. S. asks: How will I obtain a finish or polish on wood lathe work, to imitate gutta-percha? A. A small quantity of good Japan black will probably give satisfaction. The wood should be dry, and if possible, warm.

(15) L. B. R.—For solution of the wagon wheel problem, see p. 394 of last vol. of SCIENTIFIC AMERICAN.

(16) J. C. G. writes: I am building a steamer 30 feet long, 6 feet beam; my engines are a double 3 x 4. Have I power enough to propel such a boat 8 miles an hour? Do I get the same effective force in fresh water as I would in salt? A. The engines are of sufficient size. In fresh water, the immersed section is a little greater than in salt water.

(17) J. E. W. says: 1. Can an ice yacht, vessel, or any other object, sail faster than the wind? A. A first class ice boat running on smooth ice, managed by an experienced captain, will travel sixty miles an hour, the velocity of the wind that drives the boat being only fifteen miles an hour. For explanation, with engraving of boat see SCIENTIFIC AMERICAN SUPPLEMENT No. 61. 2. If so, is not the cause greater than the effect or is not the created greater than the creator? A. These queries are a little mixed. 3. The above questions were discussed before the Wilmington, N. C., Library Association, and were left for your decision in your journal. A. Your association should take the SCIENTIFIC AMERICAN, in which hundreds of interesting practical questions are presented, with information promotive of intelligent discussion.

Any numbers of the SCIENTIFIC AMERICAN SUPPLEMENT referred to in these columns may be had at this office. Price 10 cents each.

COMMUNICATIONS RECEIVED.

The Editor of the SCIENTIFIC AMERICAN acknowledges with much pleasure the receipt of original papers and contributions on the following subjects: Human Knowledge. By G. V. On Telephones and Sounders. By J. E. N.

[OFFICIAL.]

INDEX OF INVENTIONS FOR WHICH Letters Patented of the United States were Granted in the Week Ending December 3, 1878, AND EACH BEARING THAT DATE. [Those marked (r) are reissued patents.]

A complete copy of any patent in the annexed list, including both the specifications and drawings, will be furnished from this office for one dollar. In ordering, please state the number and date of the patent desired, and remit to Munn & Co., 37 Park Row, New York city.

Table listing various inventions and their patent numbers, including items like Amalgamator, Animal trap, Axle bearing, Barrel pulverizer, Battery carbon connector, Bed bottom, Bed, cast, Murray & Baker, Belt fastener, Boilers, Boiler water feeder, Book cover protector, Boot and shoe nailer, Boot and shoe upper, Bottle stopper cap, Bottle stopper fastener, Bottle stopper fastener, Braid, card for, Brake rod attachment, Brake, wagon, C. F. Whipple, Brick mould, J. H. Durrrough, Bung for casks, A. Zoller, Burring machine, F. G. Sargent, Button, sleeve, L. Barre, Camera, S. L. Bergstresser, Can, sheet metal, J. S. Field, Cane juice defecator, W. H. Filant, Caoutchouc or kerite, artificial, A. G. Day, Capstan, Henthorn & Thayer, Capsule filler, T. Whitfield, Car coupling, C. W. Cornell, Car pipe coupling, F. King, Carriage dash, B. J. Warden, Carriage step, F. A. Sawyer, Carriage top joint, J. G. English, Cartridge, shot, H. H. Schleber, Caster, sewing machine, R. Wehrle, Casting, moulds for, S. J. Adams, Chair back and bottom, F. G. Johnson, Chair, barber's, J. Clough, Chair, sewing, G. C. Bovey, Chuck, G. Gage, Churn motor, H. A. Turner, Cigar perforator and match box, W. B. Conway, Cloth folder, L. J. Boillot, Clothes line reel, F. Heavener, Cock, stop, G. A. Fischer, Coffee pot, J. A. Antunes, Coffin head rest, W. W. Ball, Cotton chopper and rake, Sprague & Clardy, Cultivator and seeder, gang, J. Sherrill, Cutter head, J. H. & H. F. Guiley, Door hanger, A. C. Arnold, Dredger and ditcher, D. Bridges, Driers, paddle for, B. F. Brightman, Drill for stone working, etc., hand, A. Nicol, Drill, seed, W. A. Turner, Electric light reflector, A. A. Lambert, Engine, traction, R. Broja, Engine condenser, S. A. Goodwin, Fare box, J. B. Slawson, Feather renovator, D. D. Sanders, Feed water heater, E. Huber, Felting machine, H. G. Ellsworth, Fence, W. Hyatt, Fence, iron, F. O. Hanson, Filtering frame, C. L. Holt, Firearm lock, W. W. Dodge, Firearms ornamentation, O. Bodenstein, Fire escape, J. Kerr, Fire kindler, J. D. Walker, Flour, buckwheat, N. H. & A. G. Gilbert, Fly trap, W. Smith, Fork, horse hay, B. Jackson, Fountain pen, J. G. Cross, Furnace, hot air, J. M. Graf, Garbage receptacle, J. J. Slevin, Glass designs, etc., J. Gast, Glass, ornamented window, R. M. Tudor, Grafting implement, W. H. Gray, Grain binder, J. F. Gordon, Grain binder, H. A. & W. M. Holmes, Grain binder, G. Warner, Grate bar, Clarke & Van Wagenen, Grate bearing bar, J. Bamrick, Guano distributor, J. P. Lowell, Gun barrel fore end stock, G. Hackett, Gun, breech-loading, Scott & Baker, Harrow, T. A. Hansley, Harrow and cultivator, rotary, S. Smith, Hat, W. Wetzel, Hat shaving machine, R. Eickemeyer, Hat and capswave band, T. W. Bracher, Headlight, signal, Dressell & E. H. & J. G. Voth, Heating apartments, etc., I. A. Salmon, Hoisting apparatus, tobacco, L. W. Brewster, Hoop fastener, A. Andren, Hoop, trundling, H. L. Barthes, Horseshoe calk, H. A. Bartholomew, Hose band, F. W. Robertshaw, Hose clamp, D. D. Hayes, Hose rack, T. J. Cain, Hydrant, H. C. Apel, Incubator, etc., regulator, E. S. Renwick, Ironing and bosom board, G. C. Carnell, Kerite, etc., A. G. Day, Leather finisher, H. Staib, Lighting apparatus, J. A. Fouchet, Load binder, H. A. Harris, Lock, alarm, Lumpkin & Benson, Lock, indicator, J. H. Kinsman, Locomotive tender buffer, G. W. Prescott, Lubricating compound, J. M. Lippincott, Mail bag, P. S. & F. M. Thomson, Mail bag, Weaver & Judson, Mail bag fastener and tag holder, J. B. Gathright, Malt extract, J. Carrick, Meat tenderer, T. J. Coulter, Mechanical movement, J. E. Crisp, Medical compound, J. W. B. Turk, Middlings separator, J. W. Pyne, Millstone driver, P. H. Childress, Mould, sand core, S. J. Adams, Mop and brush holder, M. N. Lovell, Motion transmitter, G. H. Russell, Motion transmitter, E. Vicaire, Musical instrument, H. B. Horton, Necktie, J. E. Fleisch, Nut lock, R. S. Hazen, Sr., Oar and oar lock, N. B. Cook, Package band, R. Trautmann, Packing piston and valve, G. M. Davis, Paper box, C. F. Taylor, Paper folding machine, G. Lauder, Paper for bank notes, G. W. Castles, Paper pulp screen, S. L. Gould, Pipe coupling or joint, J. Enright, Planter, corn, Hearst & Dunn, Planter, corn, M. Humphrey, Planter, seed, D. W. Hoshall, Plow, S. P. McKinny, Plow jointer, W. J. Welling, Plow, riding, D. W. Hughes, Pole, vehicle, B. H. Shearer, Polishing iron, W. W. Nixon, Press, baling, W. C. Bibb, Sr., Press, hay, I. R. Kulp, Printing machine, can, W. R. Norris, Radiator, heat, J. N. Farnham, Rake, garden, S. D. Carris, Registering machine, R. H. Ingersoll, Refrigerator, J. C. Moore, Refrigerator building, T. Krausch, Rein attachment, check, O. Hanks, Rubber or kerite, India, A. G. Day, Saddle, harness, A. Ortmayer, Sails, reefing and furling, W. H. Spooner, Salt, recovering, J. H. Konig, Sash balance, C. T. Brittain, Saw guide, circular, J. Casson, Saw mill head block, B. E. Sergeant, Saw, scroll, G. W. Griffin, Scales, spring weighing, L. E. Brown, Screen, window, E. T. Burrows, Sewer gas extractor and consumer, B. S. Alexander, Sewing machine thread cutter, H. Pollock, Show box cover, Mayo & Atkinson, Sieve, L. E. Ambrose, Smokestack cone, G. W. Prescott, Spinning ring, etc., J. Birkenhead, Spittoon, dental, G. W. Archer, Spring, bed, L. Wildermuth, Spring, wagon bolster, H. J. Gage, Stamp drier, J. F. Seymour, Stamp, hand, E. Gumbs, Stave dresser, A. M. Benson, Steam generator, W. F. Browne, Stove back lining, C. W. Warner, Stove pipe elbow, W. Redett, Stove draught deflector, T. B. Way, Tack driver, P. S. Felter, Tank, service, J. Foley, Thrasher, band cutter, M. W. Freeman, Tobacco substitute, J. P. R. James, Tool handle, A. S. Pennington, Toy perambulator, S. W. Adams, Trimmings, shaping dress, G. Simon, Valve grinder, J. H. Phelan, Vapor burner, J. Bowers, Vehicle, J. C. Russell, Velocipede, J. B. Root, Vise, standing bench, J. K. B. Solomon, Vulcanized compounds, manufacture, A. G. Day, Washer cutter, A. J. Palmer, Well packers, anchor for oil, L. Stewart, Whiffletree, C. D. Marsh.

Whiffletree iron, C. H. Palmer, Jr. 210,554
Whiffletree plate, B. S. Porter 210,557

TRADE MARKS.

Axes and hatchets, W. H. Crossman & Brother 6,854
Beer, ale, and porter, Schramm & Schnabel 6,862
Cigars, cigarettes, etc., H. M. Morris 6,861
Healing compound, B. W. Dyer 6,856
Lye in packages for domestic use, Excelsior Lye Company 6,863, 6,864, 6,865
Medical preparation, A. J. Seymour 6,860
Pistols and guns, Graham & Haines 6,859
Prepared chocolate, E. Guitard 6,858
Preparation for removing stains, etc., from silk, woolen, etc., Western Manufacturing Company 6,866
Roasted coffees, ground spices, pepper and mustard, E. Guitard 6,857
Skirts and corsets, Detroit Skirt and Corset Co. 6,855

DESIGNS.

Bedsteads, J. Dawson 10,936
Cooking ranges, Vedder & Heister 10,940
Cooking stoves, Vedder & Heister 10,945
Covers for Bibles, F. M. Dillie 10,943
Crocheted jacket, J. Holmes 10,937
Handkerchief border, J. Grimshaw 10,944
Running gear for baby carriages, A. Shoeninger 10,938
Sleds, A. Shoeninger 10,939
Stoves, Vedder & Heister 10,941, 10,942

FOR THE WEEK ENDING DECEMBER 10, 1878.

Advertising merchandise car, A. H. Burhans 210,595
Awning fastening, W. H. Macy 210,699
Ax handle attachment, G. P. Morrill 210,703
Axle, car, N. Jones 210,783
Axle, car, W. H. Murphy 210,623
Axle, car, O. D. Spalding 210,814
Axle tree spindle, R. H. Arnold 210,742
Bale tie, wire, J. M. Pollard 210,629
Barrel hoop stretcher, D. Stallard, Jr. 210,315
Barrel vent, W. Thomas 210,821
Bed bottom, C. J. Clements 210,752
Bedstead, folding, J. T. Hatfield 210,606
Bedstead, wardrobe, H. S. Hale 210,777
Bee hive, E. Armstrong 210,592
Blind, window, H. M. Ambler 210,591
Bluing package, H. Sawyer 210,808
Book cover protector, L. D. Reynolds 210,711
Book stitchee, A. A. Johnson 210,782
Boot, H. E. Van Benschoten 210,824
Boot sole edge trimmer, J. D. Westgate 210,829
Boot jack, J. Martin 210,795
Bracket, adjustable, J. C. Lake 210,697
Brick and tile kiln, N. B. Heafer 210,692
Bridge, truss, S. Conklin 210,754
Buttons, etc., of vegetable ivory, W. J. Lewis 210,617
Candlestick, L. Leonard 210,790
Car coupling, M. Burpee 210,597
Car coupling, Krick & Raichard 210,615
Car seat and couch, C. A. Piccioli 210,628
Car sealer, W. S. Brewster 210,746
Carbureter for cars, W. M. Sloane 210,717
Carriage clip die, M. Hine 210,694
Centrifugal machine, Bell & Goldsack, Jr. 210,657
Cereal drier, F. A. Luckenbach 210,793
Chair, adjustable, G. Wilson 210,733
Chairs, etc., covering for, J. H. Travis (r) 8,519
Chatelaine, G. D. Stevens 210,816
Cheese cloth cutter, O. C. Harris 210,773
Churn, G. R. Nebinger 210,800
Cigar machine, R. Roberts 210,632
Clasp, F. B. Brown 210,625
Clock, calendar, T. H. Mott 210,704
Clock dial, S. E. Root 210,806
Clock, time registering, Lane & Hill 210,788
Clothes, lock work for, J. Connor 210,755
Clothes line fastener, J. P. Boesen 210,658
Coffee mill, J. C. Dell 210,676
Coffee separator, H. B. Stevens 210,817
Coin tray cover, J. F. Miller 210,621
Cooking apparatus, feed, A. Knox 210,614
Cotton condenser, J. T. Donovan 210,678
Crane, traveling, W. H. Elliot 210,601
Crank handle, W. B. Coates 210,629
Cream raiser, S. S. Weldon 210,729
Cultivator, M. Smith 210,718
Cup and saucer holder, T. Haviland 210,688
Dash rail fastener, J. F. Fowler 210,773
Door holder, O. Dorsey 210,764
Draught apparatus, artificial, J. B. Andrews 210,740
Drill, grain, Smith & Thomas 210,719
Drop light, H. Iden 210,781
Drum, heating, W. L. Phillips 210,627
Elevator safety attachment, R. H. Hill 210,693
End gate wagon, G. S. Cryne 210,756
Excavator support, H. T. Stock 210,724
Fan and caster, J. S. Letord 210,791
Feather renovator, D. Eddy 210,768
Fence, Davis & Beermann 210,757
Fence, iron, J. H. Van Dorn 210,825
Fence post, L. Turner 210,648
Fifth wheel coupling, W. Lehmann 210,789
Fifth wheel coupling yoke, C. W. Saladee 210,637
Fifth wheel, vehicle, J. Deebie 210,675
File, W. Millsbaugh 210,739
Firearm, breech-loading, E. L. Perry 210,626
Firearm, revolving, A. L. Sweet 210,725
Fire escape, E. L. Burnham 210,596
Fluting iron, J. Neill 210,801
Fly wheel, J. W. Robertson 210,633
Friction clutch, Burwell & Bates (r) 8,518
Fruit picker, W. W. Rodgers 210,634
Furnace and damper regulator, R. L. Walker 210,649
Furnace, reversible melting, A. Plat 210,707
Furnace movable fire bar, A. E. Wackernle 210,827
Gas light extinguisher, Brand & King 210,693
Gas regulator, J. L. Chapman 210,750
Gate, R. J. Booth 210,660
Gate, A. G. Rockfellow (r) 8,515
Gate, farm, S. C. Shoup 210,640
Gate fastener, R. J. Booth 210,659
Gate, iron, S. Rogers 210,805
Gate valve, E. Allt 210,738
Glass, annealing, C. R. Weyer 210,731
Glove, S. Goge 210,775
Grain binder, J. F. Steward 210,723
Hame fastener, F. Frank 210,603
Harrow, A. F. French 210,682
Harrow, S. C. Matteson 210,702
Harvester, corn, Stewart & Jones 210,818
Hat block, elastic, R. Eickemeyer 210,771
Hat body stretcher, R. Eickemeyer 210,770
Hide and skin dresser, J. W. McDonald 210,797
Heating and cooling apparatus, E. Maw 210,796
Hinge, H. E. Griffin 210,686
Hinge, spring, I. S. Davis 210,758
Hoisting block universal joint, C. W. Hunt 210,608
Horseshoe and pad, G. C. Shaw 210,812
Ice tongs, N. R. Allen 210,737

Indicator for steam engines, etc. H. Tabor 210,643
Indicator, office, J. S. Duffie 210,765
Indicator, station, F. C. D. McKay 210,798
Iron, cleaned and planished, W. D. Wood 210,735
Knitting machine needle, G. H. & H. Adams 210,653
Ladder, J. E. Richard 210,630
Lampblack apparatus, J. M. Cornell 210,672
Lamp, electric, Sawyer & Man 210,809
Lantern, H. Nahe 210,624
Lantern and lamp, Ewing & Bill 210,602
Last, F. A. Beach 210,744
Leather, etc., artificial, E. E. Ball 210,655
Leather splitter, G. L. Tyler 210,823
Lifting jack, Platt & Orwig 210,708
Liquid measure, J. J. Roberts 210,631
Lock, J. Sargent 210,807
Lock, seal, Smith & Vowles 210,641
Loom, Colvin & Remington 210,670
Loom for weaving leno, etc., T. Aldred 210,736
Loom temple for tubular fabrics, G. F. Simon 210,715
Main tapper, J. Penney 210,706
Meat tenderer, C. K. Whittier 210,652
Motion, reciprocating, Potter, Jr., & Hubbard 210,709
Motor, W. Dickinson 210,760
Mower, lawn, J. Lusher 210,794
Mower, lawn, A. P. Osborne 210,625
Mower, lawn, W. D. Ayers 210,654
Mowing machine, L. D. Minnick 210,622
Nets for horses, Hy, S. Stewart 210,819
Nitro-cellulose manufacture, J. W. Hyatt 210,611
Oatmeal machine, J. F. Byers 210,667
Ore washer, F. A. Huntington 210,609
Organ, reed, H. W. Smith (r) 8,516
Overalls, G. Schollian 210,713
Paddlewheel, G. L. Elliott 210,800
Paint, disinfecting, D. E. Breinig 210,664
Paper board manufacture, J. F. Sheeder 210,714
Paper holder, W. H. Douty 210,679
Paper pulp washer, Hyatt & Jarvis 210,612
Paper to take copies, F. Hawke 210,690
Pea and bean huller, J. M. Turner 210,727
Photographic studio, E. C. Thompson 210,645
Piano action, Schwander & Herrburger 210,638
Piano key, J. W. Hyatt 210,780
Piano stool, J. Briggs 210,598
Pitman connection, A. Tornquist 210,646
Plating machine, E. S. Harding 210,605
Planter, corn, C. E. Coe 210,753
Planter, cotton and corn, J. M. Hall 210,694
Plow, J. Urie, Sr. 210,728
Pocketbook frame, R. Debacher 210,759
Press, baling, Squires & Kaiser 210,721
Printing press, plate, W. S. Appleton 210,741
Propeller, endless chain, J. Goodrich 210,685
Pump, W. C. Nelson 210,802
Pump valve, E. Hawkes 210,691
Pumps, piston for oil well, J. B. Potter 210,710
Pyrites, treating burnt, J. Mason 210,619
Rail chair, J. R. Neff 210,705
Rail fastener, F. B. Freudenberg 210,774
Railway crossing, E. Shelton 210,639
Railway rail, curved, W. W. Humphrey 210,696
Railway rail manufacture, B. C. Lauth 210,616
Railway safety gate, H. A. Stearns 210,642
Railway track tie and support, G. F. Folsom 210,681
Railway permanent way, C. Wood 210,734
Rake, cranberry, H. Crowell 210,599
Rake, lawn, J. Welchhart 210,650
Roofing, sheet metal, W. G. Hyndman 210,613
Sawing machine, scroll, J. H. Hopkins 210,607
Saws, hanging gang, C. Lamb 210,787
Scraper, road, P. B. Thaxton 210,726
Screw threads in sheet metal, King & Dougherty 210,784
Scythe snath fastener, J. Simpson 210,716
Seeder, cultivator, etc., Galloway & Larsen 210,633
Sheet metal vessels, J. Chaumont 210,751
Ships, loading and unloading, H. P. Tothammer 210,647
Shoe, F. M. Hoyt 210,695
Shoe or garment fastening, L. Magniez 210,700
Shovel, fire, S. Whitman 210,732
Show box, T. Haviland 210,689
Skate, E. F. Weston 210,730
Slipper, Burch & Curtiss 210,594
Spark arrester, D. Wiser 210,828
Spark extinguisher, J. H. Bartlett 210,656
Spectacles, lens for, J. R. Rowell 210,712
Spring for tilting chairs, H. Howson 210,779
Spring, vehicle, S. D. King 210,785
Spring, vehicle, W. F. Whitney (r) 8,517
Stamp, ore, F. A. Huntington 210,610
Stamp, revenue, Bowles & Eastlake 210,661
Staple holder, W. J. Brown, Jr. 210,748
Steel manufacture, F. Berchtold 210,745
Stocking, A. Selby 210,810
Stocking supporter, F. B. Brown 210,666
Stove door knob, W. Cunliff 210,673
Stove grate dumper, A. J. Redway 210,804
Street sweeper, C. W. Cunningham 210,674
Sugar mixing apparatus, D. Edwards 210,769
Sulky, trotting, W. J. Hamill 210,687
Suspender loops and studs, J. P. Lindsay 210,732
Table, folding, W. Thomas 210,822
Telephone, speaking, E. Gray 210,776
Thrashing machine, L. Bronson 210,747
Tobacco pipe, G. Castleden 210,598
Tongs, pipe, O. B. Lay 210,698
Truck, car, J. G. Tait 210,644
Truck center bearer, G. Chalender 210,749
Trunk, J. C. Locke (r) 8,520
Trunk, E. Sempie (r) 8,521
Type writer, H. & F. Anderson 210,739
Umbrella runner, O. M. Smith 210,813
Valve, check and safety, T. Duffy 210,766
Valves for barrels, kegs, etc., J. Byrne 210,668
Vehicle coupling, S. W. Baldwin 210,743
Vehicle dash rail, F. J. Derrig 210,600
Vehicle shifting rail, E. Miller 210,620
Ventilator, E. G. Sternberg 210,722
Vessels, armor for, E. W. Serrell 210,811
Vocal engine, T. A. Edison 210,767
Wagon cover, reversible, J. Boyle 210,662
Wagon rack, L. Talcott 210,820
Wagon, road, C. W. Saladee 210,635
Water closet, J. Demarest 210,677
Water closet, urinal, T. G. Knight 210,786
Well tools, joint for oil, H. S. Southard et al. 210,720
Wells, rod adjuster for oil, P. H. Melvin 210,618
Wheel, car, I. H. Congdon 210,671
Wheelbarrow, J. W. Marshall 210,701
Whiffletree, S. J. White 210,651
Windmill, W. Forbes 210,772
Windmill motor, I. H. Palmer 210,803
Woodworker, universal, Doane & Bugbee, 210,761, 210,762, 210,763

Wrench, nut and tap, J. Goodrich 210,694

TRADE MARKS.

Ale, H. & G. Simonds 6,858
Chewing and smoking tobacco, cigars, cigarettes, and snuff, Marburg Brothers 6,872
Cigars, H. A. Miller 6,867

Cologne water, Wexford Company 6,869
Cutlery, G. Wostenholm & Son 6,870
Hosiery and knit goods, Jenson & Hanifen 6,874
Plug chewing tobacco, H. M. Cochran 6,873
Print butter, A. E. Phillips 6,875
Teas, Griffin & Co. 6,871

DESIGNS.

Breastpins, H. S. Somes 10,960
Brooch, S. C. Howard 10,958
Combined glass vessels, F. C. Winship 10,954
Font of printing types, T. MacKellar 10,955
Group of statuary, J. Rogers 10,956
Oil cloth, C. T. & V. E. Meyer 10,946 to 10,952
Shoes, Kenz & Kraft 10,959
Stoves, Vedder & Ritchie 10,953, 10,957
Woven borders for towels, R. T. Webb 10,961, 10,963
Woven fabrics, R. T. Webb 10,962, 10,964

English Patents Issued to Americans.

From December 20 to December 27, inclusive.
Book binding.—E. S. Boynton, Bridgeport, Conn.
Boxes for tooth powder.—M. Bernheim, N. Y. city.
Electric lighting apparatus.—J. B. Fuller, N. Y. city.
Paper press.—J. W. Jones, Harrisburg, Pa.
Printing plates.—D. Slote, N. Y. city.
Printing press.—P. H. White et al., Philadelphia, Pa.
Sewing machines.—J. H. House, Bridgeport, Conn.
Wood, preserving.—T. A. Dowling et al., N. Y. city.

The Scientific American EXPORT EDITION.

PUBLISHED MONTHLY.

THE SCIENTIFIC AMERICAN Export Edition is a large and SPLENDID PERIODICAL, issued once a month, forming a complete and interesting Monthly Record of all Progress in Science and the Useful Arts throughout the World. Each number contains about ONE HUNDRED LARGE QUARTO PAGES, profusely illustrated, embracing:

- (1) Most of the plates and pages of the four preceding weekly issues of the SCIENTIFIC AMERICAN, with its SPLENDID ENGRAVINGS AND VALUABLE INFORMATION.
(2) Prices Current, Commercial, Trade, and Manufacturing Announcements of Leading Houses. In connection with these Announcements many of the Principal Articles of American Manufacture are exhibited to the eye of the reader by means of SPLENDID ENGRAVINGS.

This is by far the most satisfactory and superior Export Journal ever brought before the public.

Terms for Export Edition, FIVE DOLLARS A YEAR, sent prepaid to any part of the world. Single copies, 50 cents. For sale at this office. To be had at all News and Book Stores throughout the country.

NOW READY.

THE SCIENTIFIC AMERICAN EXPORT EDITION FOR JANUARY, 1879, WITH ONE HUNDRED AND TEN ILLUSTRATIONS.

GENERAL TABLE OF CONTENTS

Of the SCIENTIFIC AMERICAN Export Edition for January, 1879.

- I.—INVENTIONS, DISCOVERIES AND PATENTS.
London, Berry & Orton's Band Saw Mill. One engraving.
A New Carpenter's Plane. One engraving.
Confiscation of American Patents.
An Imported Railway Decision.
A Scientific Invention Wanted.
The Rapiet Electric Light. Three engravings.
A New Foot Lathe. Four engravings.
Description of the Recent Most Important Engineering Inventions.
A New Bench Plane. Two engravings.
Double Screw Parallel Vise. One engraving.
Description of Recent Most Important Mechanical Inventions.
A Remedy Worse than the Disease.
Patent Office Practice.
A New Revolving Index. One engraving.
Amateur Inventors.
Paper for Preventing Fraud.
A Novel Cooler. Two engravings.
The Casson-Dormoy Furnace. Two engravings.
A Substitute for Pens and Ink.
Description of Recent Most Important Agricultural Inventions.
Patents in New South Wales.
The Trade Marks Quandary.
Senate Bill 300. Section 2.
Progress of the Swedish Arctic Expedition.
Straub's Scientific Grain Mill. Three engravings.
The Columbia Bicycle. One engraving.
Duplex Steam Pumping Engine. One engraving.
The Clipper Injector. Two figures.
Description of the Recent Most Important Miscellaneous Inventions. Eight engravings.
A New Method of Setting Boiler Tubes. Five figures.
The Bill to Discourage Inventions.
An Improved Table. One illustration.
Who Invented the Torpedo Boat? Two engravings.
Saturator and Regulator of Mekarski's Compressed Air Motor. Two engravings.
Rotary Lift Pump. One engraving.
A Novel Bridle Bit. One figure.
A New Continuous Calk Horseshoe. Two engravings.
Military Improvements Wanted.
The Wallace Farmer Electric Light. Two figures.
A New Firearm. One engraving.

- II.—MECHANICS AND ENGINEERING.
Proportions of Hulls, Engines, and Boilers of Yachts.
A Fast Little Side-Wheeler.
Asphalt Pavements.
The Drainage of Lake Fucino.
Trial of Brainerd's Exhaust Pipe.
Miss Hosmer's Motor.
Chester Water Works. Five figures.
Choked Feed Pipes. Two figures.
Iron Wood Screws, etc.
Machinery.
Boiler Feeders for Locomotives, etc.
An Economical Engine.
General Daniel Craig McCallum.
A Fast Little Steam Yacht.
Medals for Fairbanks' Scales.
The Largest Locomotive Engine.
Amateur Mechanics. Chucking. Fourteen engravings.
Excavator on the Ghent and Terneuzen Ship Canal, Belgium. One illustration.
Weatherproof Houses.

- III.—MINING AND METALLURGY.
Mining Notes.
Alloys.
Vienna Bronze Work. One engraving.

New Metals.
A Canadian Gold Mine.
Malleable Brass.

IV.—CHEMISTRY AND PHYSICS.

A Practical Application of the Electric Current.
American History of the Electric Light.
The Constitution of Matter in the Gaseous State.
Action of Water and Salt Solutions on Zinc.
Astronomical Notes. Giving the Positions, Rising, and Setting of the Planets for January.
The Supposed Volcano in the Moon.
Improved Musical Condenser. One figure.
Mean Distance of Water Molecules.
The First Electric Lamps.
Anhydrous Sulphuric Acid.
Crystallized Javelle Water and Chlorozone.
Salicylic Acid with Boracic Acid.
Methyl Aldehyd.
Chemistry in Schools and Colleges.
Baking Powders and Glucose Sirups.
Electric Illumination. Three engravings.
Is Science Benevolent?
The Volatile Oil of Hops.
Sun Spots and Commercial Crises.
Easily Made Physical Apparatus. Seven engravings.
The Telephone in Philadelphia.
Early History of the Electric Light.
The Gruey Gyroscope and the Gyroscopic Pendulum. Two figures.
Recent Facts about Poisons.
The Transmutation of Elements.
The Fourth State of Matter.
The Electric Light in London.
The Microphone.
The Black Spot on Jupiter's Disk.
Nitric Acid produced by the Electric Light.
A New Form of Sulphureted Hydrogen Apparatus. One engraving.
New Cautics.

V.—NATURAL HISTORY, NATURE, MAN, ETC.

The Breeding of Eels.
Hair of the Musk Turtle.
The Evaporation of Moisture from Leaves.
Natural History Notes.
Curiosities of Botany.
A Three-Legged Woodcock. One illustration.
Experiment with Carnivorous Plants.
Studies from the Brighton Aquarium. One illustration.
Remarkable Mortality of Fish.
The Last Eruption of Mt. Vesuvius.
The Catalpa.
The Luray Cavern.
Useful and Miscellaneous Birds.
The Chaetodon. One engraving.
A Disagreeable Discovery.
The Mahua Tree.
Moral Influence of the Study of Natural Science.
Le Conte's Theory of Mountain Formation.
New Coral Beds near Sicily.
The Fencible Ear Hog. One illustration.
American Dinosaurs.
Milk Snake Swallowing a Striped Snake.
Popular Errors Regarding Papyrus.

VI.—MEDICINE AND HYGIENE.

New View of Infection.
Sanitary Uses of Gunpowder.
Cost of the Yellow Fever.
A Curious Surgical Operation.
Effects of Food upon the Bones.
Toad Poisoning.
Sulphur for Diphtheria.
Spreading Diphtheria by Kisses.
The Treatment of Baldness.
Microscopic Examination of Meat.
Oatmeal Diet.
Two Varieties of Sciatica.

VII.—THE PARIS EXHIBITION, SCIENTIFIC MEETINGS, ETC.

Belgian Furniture at the Exhibition. One illustration.
The French Telegraphic Annex. One illustration.
Upholsterers' and Decorators' Work, French Section. One illustration.
Carpets, Tapestry, etc., French Section. One illustration.
Sack Holders and Lifters at the Exhibition. Eight engravings.
Early English Style of Piano at the Exhibition. One figure.

VIII.—INDUSTRY AND COMMERCE.

Trade Depression in England.
The South as the Competitor of England.
William H. Rulofson.
Manufacturing Industries.
Pure and Unadulterated Baking Powders.
Promised Revival of Sodom and Gomorrah.
A Plan of Co-operative Charity.
African Industries. No. 1. How Tobacco and Snuff are made.
A Model New England Farm.
Defeat of the Cochran Ring.
The Orange Trade in New York.
Bronze Lattice or Fire Guard. One engraving.
The Manufacture of Soft Felt Hats.
England Taking a Hint.
The Adulteration of Soft Soap.
American Industries. No. 2. The Utilization of Graphite. Five engravings.
A Mammoth Farm.
The Supply of Boxwood.
Relative Earnings of Capital and Labor.
Electricity in Silk Winding.
An International Fish Show.
Petroleum Notes.
American Industries. No. 3. Refining Sugar. Nine illustrations.
Catching Cod with Nets.
Shifting of the Grain Belt.
The Antiquity of Weaving.
Cattle Raising in Montana.
Wine from Oranges.
A Little Seaport's Monopoly.
Brier Root Pipes.
Cincinnati Faience.
Elizabethan Fireplace. One engraving.
The American Potteries.
Staining Floors.

IX.—PRACTICAL RECIPES AND MISCELLANEOUS.

Toil and Be Happy.
Theory and Practice.
Impervious Rubber Tubing.
Erin go Bragh.
Look to Your Fireplaces.
Good Sausages.
Over-Density of Population in Cities.
How to Utilize Old Fruit Cans.
Kerosene Dangers.

Answers to Correspondents, embodying a large quantity of valuable information, practical recipes, and instructions in various arts.
Single numbers of the Scientific American Export Edition, 50 cents. To be had at this office, and at all news stores. Subscriptions, Five Dollars a year; sent postpaid to all parts of the world.

MUNN & CO., PUBLISHERS, 37 PARK ROW, NEW YORK.

To Advertisers: Manufacturers and others who desire to secure foreign trade may have large and handsomely displayed announcements published in this edition at a very moderate cost.

The Scientific American Export Edition has a large guaranteed circulation in all commercial places throughout the world. Regular Files of the Export Edition are also carried on ALL STEAMSHIPS, foreign and coastwise, leaving the port of New York. Address MUNN & CO., 37 PARK ROW, NEW YORK.

Advertisements.

Inside Page, each insertion --- 75 cents a line. Back Page, each insertion --- \$1.00 a line. (About eight words to a line.) Engravings may head advertisements at the same rate per line, by measurement, as the letter press. Advertisements must be received at publication office as early as Thurs day morning to appear in next issue.

Founded by Mathew Carey, 1785.

BAIRD'S BOOKS FOR PRACTICAL MEN.

Our new and enlarged CATALOGUE OF PRACTICAL AND SCIENTIFIC BOOKS, 96 pages, 8vo; a Catalogue of Books on DYEING, CALICO PRINTING, WEAVING, COTTON and WOOLEN MANUFACTURE, 4to; Catalogue of a choice collection of PRACTICAL, SCIENTIFIC, and ECONOMIC BOOKS, 4to; List of Books on STEAM AND THE STEAM ENGINE, MECHANICS, MACHINERY, and ENGINEERING, 4to. List of Important Books on METALLURGY, METALS, STRENGTH OF MATERIALS, CHEMICAL ANALYSIS, ASSAYING, etc., 4to; two Catalogues of Books and Pamphlets on SOCIAL SCIENCE, POLITICAL ECONOMY, BANKS, POPULATION, PATTERISM, and kindred subjects sent free to any one who will forward his address.

HENRY CAREY BAIRD & CO., Industrial Publishers, Booksellers, and Importers, 810 WALNUT STREET, PHILADELPHIA.



THE "NEW MONITOR" WHOLE POOL SEWING MACHINE. The greatest achievement of the age. No shuttle, no bobbin, no winding of threads. Sewing directly from two whole spools. Self-adjusting automatic tension. Warranted five years. Price \$18. Send stamp for illustrated circular. G. L. DU LANEY & CO., 27 West 13th Street, Near 5th Ave., N. Y. city.

ICE AND ICE-HOUSES—HOW TO MAKE ice ponds; amount of ice required, etc., and full directions for building ice-house, with illustrated plan. SUPPLEMENT 55. Price 10 cents.

CIRCULAR.

ADJUTANT GENERAL'S OFFICE, WASHINGTON, December 28th, 1878. THE Board on Equipments for the United States Army, in session in this city, respectfully invite brief communications from persons in the military service, regarding any improvements that can be made in the general equipment of troops which have been suggested by observation and experience, and would request inventors and manufacturers to forward to the Board samples, accompanied by drawings and specifications, of any improvements made in the equipment of troops; keeping in view the importance of lessening the weight to be carried by the soldier, increasing his efficiency, and at the same time preserving or increasing the durability of the articles to be used. OFFICIAL: E. D. TOWNSEND, Adj't. General.

\$6 FOR 56 cts.

A Special Offer to the Readers of this Paper.

THE ILLUSTRATED DICTIONARY

Containing nearly 29,500 words. Orthography, Pronunciation and Definitions, according to the best English and American Lexicographers. Very handsomely bound in cloth and illustrated with 125 Engravings, sent free to any reader of this paper upon receipt of 56 cts. to pay actual postage and packing charges. Address C. E. HUNT, Rockland, Mass., dealer in books, bibles, &c. This great offer is good for 60 days only, and is made solely for the purpose of introduction. But two dictionaries will be sent to one address. This appears but once. Order Now. Send silver, currency or stamps.

GOLD, SILVER, AND NICKEL PLATER WANTS Situation. Address PLATER, Oakville, Conn.

Say where you saw this. Champion Combination and Youth's Combination Foot Lathes, Amateur Steam Engines & Boilers, Cylinder Saws and Planes, Machines, Send stamp for price. Strang's Cylinder Saw & Mach. Co., Taunton Mass.

OUR FRESH STOCK OF WHITE HOLLY IS NOW READY.

This, with our complete assortment of RARE AND FANCY WOODS, is particularly worthy of the attention of wholesale buyers. In addition, our usual complete stock of sawed Hardwood, Lumber, and Veneers, figured and plain; Burls, etc. GEO. W. READ & CO., 186 to 200 Lewis Street, New York.

ICE-HOUSE AND COLD ROOM.—BY R. G. Hatfield. With directions for construction. Four engravings. SUPPLEMENT No. 59. Price, 10 cents.

FOR UNIVERSAL LATTICE DOGS, DIE DOGS, ETC., send for circular to C. W. LE COINT, S. Norwalk, Ct.

SLOWAKER'S IMPROVED WAGON SKIFF. Patented April 25th, 1876. The best in use. Simple and durable. Shop, state, or entire interest for sale on reasonable terms. For full particulars, address C. SLOWAKER, Cold Stream, Hampshire Co., W. Va.

BRADFORD MILL CO. Successors to Jas. Bradford & Co., MANUFACTURERS OF French Burr Millstones, Portable Corn & Flour Mills, Snu Machines, etc. Also, dealers in Bolting Cloth and General Mill Furnishings. Office & Factory, 158 W. 2d St., CINCINNATI, O. J. R. Stewart, Pres. W. R. Dunlap, Sec. PRICE LISTS SENT ON APPLICATION.

THE DRIVEN WELL. Town and County privileges for making Driven Wells and selling Licenses under the established American Driven Well Patent, leased by the year to responsible parties, by WM. D. ANDREWS & BRO., NEW YORK.

THE INDEPENDENT. Well and Favorably Known the World Over as the BEST Religious Weekly Newspaper. It retains all its most desirable features and adds new ones.

We shall continue to print articles from the best writers and thinkers in the country. The Departments of Religious News, Literature, Sunday-school, Fine Arts, Science, Mission, School and College, Markets, Farm and Garden, Financial, and Insurance will, as heretofore, be contributed to by specialists in each branch. These departments are famous because they are able and trustworthy.

COOK'S LECTURES. These famous Lectures, delivered in Boston every Monday, by the Rev. Joseph Cook, will be published in full, together with the introductory remarks. EX-PREST THEODORE D. WOOLSEY, D. D., will contribute 20 to 30 articles on Socialism and Communism, the most important questions of the day.

SERMONS by eminent clergymen in all parts of the country will continue to be printed.

PREMIUMS. We offer Rev. Joseph Cook's valuable new volumes, entitled "BIOLOGY," "TRANSCENDENTALISM," "ORTHODOXY," "CONSCIENCE," "HEREDITY," and "MARRIAGE," in a revised and corrected form, the author's previous remarkable Monday Lectures. They are published in handsome book form by Houghton, Osgood & Co., of Boston. We will mail a copy of any one volume, postpaid, to any subscriber to THE INDEPENDENT who remits us \$3 for a year, in advance, or any subscriber may remit \$5.50, and we will send him THE INDEPENDENT for two years, in advance, and two volumes, postpaid; or any three volumes, postpaid, to any one subscriber who remits \$8.00 for three years, in advance.

WORCESTER'S QUARTO DICTIONARY. THE STANDARD. WORCESTER'S UNABRIDGED Pictorial Quarto Dictionary. Bound in Sheep, 1854 pages, over 1000 Illustrations, Issue of 1878. RETAIL PRICE, \$10.00.

We have made a special contract with the great publishing house of J. B. Lippincott & Co., of Philadelphia, by which we are enabled to offer the most desirable Premium ever given by any newspaper in the country. We will send this, the best Dictionary published, to any person who will send us the names of Three New Subscribers and Nine Dollars; or who will, on renewing his own subscription, in advance, send us Two New Names additional and \$9.00; or who will renew his own subscription for three years, in advance, and send us \$9.00; or for a new subscriber for three years and \$9.00. The great Unabridged Dictionary will be delivered at our office, or in Philadelphia, free, or sent by express or otherwise, as may be ordered, from Philadelphia, at the expense of the subscriber. The Subscriber under this offer will not be entitled to any other Premium.

Subscription Price \$3 per annum in Advance, including any one of the following Premiums: Any one volume of the Household Edition of Charles Dickens' Works, bound in cloth, with 16 Illustrations each, by Sol Eytinge. Moody and Sankey's Gospel Hymns and Sacred Songs, No. 2. Lincoln and his Cabinet; or, First Reading of the Emancipation Proclamation. Fine large Steel Engraving by Ritchie. Size 26x36. Authors of the United States. Fine large Steel Engraving. 44 Portraits. Size 24x38. By Ritchie. Charles Sumner. Fine Steel Engraving. By Ritchie. Grant or Wilson. Fine Steel Engraving. By Ritchie. Edwin M. Stanton. Fine Steel Engraving. By Ritchie. The Inner Life of Abraham Lincoln. By Frank B. Carpenter. Bound in cloth 360 pages. It gives a better insight into his "inner life" than can be found elsewhere, and is altogether one of the most fascinating, instructive, and useful books of the kind ever published.

Subscription Price \$3 per annum in Advance. Specimen copies sent free. Address THE INDEPENDENT, P. O. Box 2787, New York City.

REGISTERED TRADE-MARK Phosphor-Bronze. Phosphor-Bronze, for General Machine Castings, Pinions, Cog Wheels, Propeller Screws, Hydraulic Presses and Pump Barrels, Piston Rods, Screw Bolts for Steam Cylinders, Hardw are, Bearings, Valves, Balls, Steam Bolts, Tubes, Plates, etc. Apply to the PHOSPHOR-BRONZE SMELTING CO., Limited, 208 Washington Ave., Philadelphia, Pa., Sole Manufacturers in U. S.

BIG PAY to sell our Rubber Printing Stamps. Samples free. Taylor Bros. & Co., Cleveland, O.

BLAKE'S STONE AND ORE BREAKER AND CRUSHER. For breaking hard and brittle substances to any size. Endorsed by the leading Mining, Manufacturing, and Railroad corporations in the United States and Foreign Countries. First Premium wherever exhibited, and hundreds of testimonials of the highest character. A NEW SIZE FOR PROSPECTING AND LABORATORY USE. ALL STONE CRUSHERS not made or licensed by us, containing vibratory convergent jaws actuated by a revolving shaft and fly-wheel, are infringements on our patent, and makers and users of such will be held accountable. Address BLAKE CRUSHER CO., New Haven, Conn.

THE HANCOCK INSPIRATOR RECENT TESTIMONY OF HIGH CHARACTER.

"For simplicity, efficiency, and cheapness, we believe the Inspirator is superior to all other boiler feeders." E. & G. FAIRBANKS & CO., St. Johnsbury, Vt.

"Don't want any more pumps to pack, oil, freeze, pound, break valves, and 1,000 other objections." B. B. SULLIVAN, Hardenburg, Ind.

"It works like a charm. Saves about one-quarter the fuel." BENT, CHEEVER & PIERCE, Clinton, Wis.

"Inspirator gives entire satisfaction." MATTHEW BROS., Chicago, Ill.

"Inspirator works well and engineer is highly delighted with it." W. I. BLACK, Greenville, Ohio.

"Inspirator works like a top, and cannot be excelled in the world in the shape of a pump." J. J. SCHULTZ & BROTHER, Bremen, Ind.

"Does all and more than you claim for it. Can recommend it to do most anything a pump will do, and with better satisfaction." JOHN W. MUELLER, Cincinnati, O.

"It is doing all that you claimed for it, and our engineers like it very much." J. N. SWETE, Dilworth Porter Co., Pittsburgh, Pa.

"Gives entire satisfaction. It will save 30 per cent. in fuel." H. C. JACOBE & BROS., Versailles, Ohio.

"Works every time without trouble. Undoubtedly the best thing of the kind. It has my unqualified approval." BROOKVILLE PAPER CO., Brookville, Ind.

"It is without exception the best boiler feeder we ever used." GEO. CHAFFEY & BROS., Shipbuilders and Engineers, Cincinnati, O.

"The little fellow surprised the natives by the manner in which it did its work." J. E. BRICHER, Fort Madison, Iowa.

"Works to a charm. We have done away with all our pumps." N. W. PARKER, Engineer, Independent Tug Co., Milwaukee, Wis.

"It is the most reliable and perfect boiler feeder we ever saw, and has been a great saving to us since we commenced to use it." GEORGE BRENNAN & SON, Apollo.

"The Hancock Inspirator is working splendidly." D. S. PATTERSON, M. M., Cincinnati, O.

"Very much pleased with it; does all that your agent claimed for it." E. A. STANLEY & Co., Monticello, Ill.

"Inspirator is working splendidly, and is doing all you claimed for it." W. C. CONWAY, Milwaukee, Wis.

"We would recommend it in preference to anything known for feeding boilers." B. D. & W. N., EISENDRATH, Chicago, Ill.

"Inspirator working splendidly." E. BOSLEY, M. of M., M. & C. R. R.

"Does the work well; most cheerfully recommend it." W. R. CORNELIUS, Nashville, Tenn.

"Gave it a good test, and find it just the thing we wanted." GEORGE P. DANA, Fire Marshal, Fond Du Lac.

"Lifting water 16 feet, and feeding boiler in a satisfactory manner." LAPORTE MILLING & MFG CO., Laporte, Ind.

Illustrated and Descriptive Circulars sent on application to

Hancock Inspirator Co., 52 CENTRAL WHARF, BOSTON.

THE FORSTER-FIRMIN GOLD AND SILVER AMALGAMATING COMPANY of Norristown, Pa., will grant state rights or licenses on easy terms. This system works up to assay, and recovers the mercury rapidly. Apply as above.

EDMUND DRAPER, Manufacturer of first-class Engineers' Instruments. Established in 1830. 226 Pear St., Phila., Pa.

"The 1876 Injector." Simple, Durable, and Reliable. Requires no special valves. Send for illustrated circular. W. M. SELLERS & CO., Phila.

Shafts, Pulleys, Hangers, Etc. Full assortment in store for immediate delivery. W. M. SELLERS & CO., 79 Liberty Street, New York.

30 Perfumed Chromo and Motto Cards, 10c. Name in Gold and Jet. Seavy Bros., Northford, Ct.

WROUGHT IRON BEAMS & GIRDERS

THE UNION IRON MILLS, Pittsburgh, Pa. Manufacturers of improved wrought iron Beams and Girders (patented). The great fall which has taken place in the prices of iron, and especially in Beams used in the construction of FIRE-PROOF BUILDINGS, induces us to call the special attention of Engineers, Architects, and Builders to the undoubted advantages of our erecting Fire Proof structures; and by reference to pages 52 & 54 of our Book of Sections—which will be sent on application to those contemplating the erection of fire proof buildings—"THE COST CAN BE ACCURATELY CALCULATED, the cost of Insurance avoided, and the serious losses and interruption to business caused by fire; these and like considerations fully justify any additional first cost. It is believed, that, were owners fully aware of the small difference which now exists between the use of Wood and Iron, in many cases the latter would be adopted. We shall be pleased to furnish estimates for all the Beams complete, for any specific structure, so that the difference in cost may at once be ascertained. Address CARNEGIE, BROS. & CO., Pittsburgh, Pa.

STEAM PUMPS. HENRY R. WORTHINGTON, 239 Broadway, N. Y. 83 Water St., Boston. THE WORTHINGTON DUPLEX PUMPING ENGINES FOR WATER WORKS—Compound, Condensing or Non-Condensing. Used in over 100 Water-Works Stations. STEAM PUMPS—Duplex and Single Cylinder.

Price list issued Jan. 1, 1879, with a reduction exceeding 30 per cent. WATER METERS. OIL METERS.

LANSDALL'S PATENT STEAM SYPHON. ANSELL AND ENG'S LEVER AND CAM GATE VALVES. WELDLESS STEEL TUBING. JOHN S. LING, 4 FLETCHER ST. NEW YORK.

WANTED TO EXCHANGE SET 52 IN. URR MILL Stones for a Turbine Water Wheel, from 30 to 40 inches. JOHN E. MAGUIRE, Lithonia, Ga.

INVENTORS AND OWNERS OF PATENTS. If you wish the true value of your patents, communicate with W. C. VAIL, (18 years' experience.) 50 Beekman St., New York.

RIVAL STEAM PUMPS. JOHN H. MCGOWAN & CO. 235 & UPWARDS W. M. P. S. CINCINNATI OHIO.

\$10 to \$1000 Invested in Wall St. Stocks makes fortunes every month. Books sent free explaining everything. Address BAXTER & CO., Bankers, 17 Wall St., N. Y.

TO MANUFACTURERS AND CAPITALISTS. Flower Pins. New article of light wire, recently patented. Patent For Sale. Correspondence solicited. Address J. H. FLUMMER, 1276 Pacific St., Brooklyn, N. Y.

THE Eclipse Engine. Furnishes steam power for all Agricultural purposes, Driving Saw Mills, and for every use where a first-class and economical Engine is required. Eleven first-class premiums awarded, including Centennial '76. Refer to No. 7, issue of Vol. No. 14, issue of 78, of SCIENTIFIC AMERICAN, for Editorial illustrations. FRICK & CO., Waynesboro, Franklin Co., Pa. When you write please name this paper.

MANUFACTURERS HAVING NEWLY patented goods never introduced, address W. C. VAIL, 50 Beekman St., New York. (18 years' experience, and responsible.)

PROSPECTUS

OF THE Scientific American FOR 1879.

The Most Popular Scientific Paper in the World.

VOLUME XL.—NEW SERIES.

The publishers of the SCIENTIFIC AMERICAN beg to announce that on the Fourth day of JANUARY, 1879, a new volume will be commenced. It will continue to be the aim of the publishers to render the contents of the new volume as, or more, attractive and useful than any of its predecessors.

Only \$3.20 a Year including Postage. Weekly. 52 Numbers a Year.

This widely circulated and splendidly illustrated paper is published weekly. Every number contains sixteen pages of useful information, and a large number of original engravings of new inventions and discoveries, representing Engineering Works, Steam Machinery, New Inventions, Novelties in Mechanics, Manufactures, Chemistry, Electricity, Telegraphy, Photography, Architecture, Agriculture, Horticulture, Natural History, etc.

All Classes of Readers find in THE SCIENTIFIC AMERICAN a popular resume of the best scientific information of the day; and it is the aim of the publishers to present it in an attractive form, avoiding as much as possible abstruse terms. To every intelligent mind, this journal affords a constant supply of instructive reading. It is promotive of knowledge and progress in every community where it circulates.

Terms of Subscription.—One copy of THE SCIENTIFIC AMERICAN will be sent for one year 52 numbers—postage prepaid, to any subscriber in the United States or Canada, on receipt of three dollars and twenty cents by the publishers; six months, \$1.00; three months, \$1.00.

Clubs.—One extra copy of THE SCIENTIFIC AMERICAN will be supplied gratis for every club of five subscribers at \$3.20 each; additional copies at same proportionate rate. Postage prepaid.

One copy of THE SCIENTIFIC AMERICAN and one copy of THE SCIENTIFIC AMERICAN SUPPLEMENT will be sent for one year, postage prepaid, to any subscriber in the United States or Canada, on receipt of seven dollars by the publishers.

The safest way to remit is by Postal Order, Draft, or Express. Money carefully placed inside of envelopes, securely sealed, and correctly addressed, seldom goes astray, but is at the sender's risk. Address all letters and make all orders, drafts, etc., payable to

MUNN & CO., 37 Park Row, New York.

To Foreign Subscribers.—Under the facilities of the Postal Union, the SCIENTIFIC AMERICAN is now sent by post direct from New York, with regularity, to subscribers in Great Britain, India, Australia, and all other British colonies; to France, Austria, Belgium, Germany, Russia, and all other European States; Japan, Brazil, Mexico, and all States of Central and South America. Terms, when sent to foreign countries, Canada excepted, \$4, gold, for SCIENTIFIC AMERICAN, 1 year; \$9, gold, for both SCIENTIFIC AMERICAN and SUPPLEMENT for 1 year. This includes postage, which we pay. Remit by postal order or draft to order of Munn & Co., 37 Park Row, New York.

Advertisements.

Inside Page, each insertion --- 75 cents a line. Back Page, each insertion --- \$1.00 a line.

Engravings may head advertisements at the same rate per line, by measurement, as the letter press. Advertisements must be received at publication office as early as Thursday morning to appear in next issue.

FOR SALE CHEAP. A very handsome Westley Richards Breech-Loading Shot Gun.

Weight, 8 lbs. 6 ozs.; 10 gauge; central fire; Brazier locks. A first-class gun in every respect, and but slightly used. A gun suitable for general shooting.

Address HODGKINS & HAIGH, 238 Broadway, New York.

OPEN BACK PRESSES. STILES & PARKER PRESS CO., Middletown, Ct.



IMPORTANT FOR ALL CORPORATIONS AND MAN'G CONCERNS. - Buerk's Watchman's Time Detector, capable of accurately controlling the motion of a watchman or patrolman at the different stations of his beat.

PHOTO VISITING CARDS. - Most wonderful discovery in photography. This style is now all the rage in PARIS. A perfect photograph of YOU, SELF and your name elegantly printed on 1 dozen GILT-EDGED (round cornered) cards, 60c.

SPARE THE CROTON AND SAVE THE COST. Driven or Tube Wells furnished to large consumers of Croton and Ridgewood Water.

H.W. JOHNS' ASBESTOS. Liquid Paints, Roofing, Boiler Coverings, Steam Packing, Sheathings, Fire Proof Coatings, Cements, &c.

Fine Pamphlets printed for 75c. a Page per 1,000. 1,000 Fine 9x12 Circulars, \$2.50. Price list or estimate and samples for stamp. 250 Hill Heads, \$1.

EGGLESTON'S ELASTIC TRUSS. Has a Pad differing from all others, in center, with Self-Adjusting Ball in center, adapts itself to all positions of the body.

LAP WELDED CHARCOAL IRON Boiler Tubes, Steam Pipe, Light and Heavy Forgings, Engines, Boilers, Cotton Presses, Rolling Mill and Blast Furnace Work.

J. LLOYD HAIGH, Manufacturer of WIRE ROPE of every description, for Railroad and Mining Use, Elevators, Derricks, Rope Tramways, Transmission of Power, etc.

Mill Stones and Corn Mills. We make Burr Millstones, Portable Mills, Smut Machines, Packers, Mill Picks, Water Wheels, Pulleys, and Gearing, specially adapted to Flour Mills.

AROMATIC SALICYLIN TOOTH WASH FOR THE TEETH, GUMS & BREATH. Warranted Pure, Harmless, and Infalible, imparting the most fragrant perfume to the breath.

SPENCERIAN STEEL PENS. Superior English make. A sample card of one each of the twenty numbers for trial, by mail, on receipt of 25 cts.

IVISOV, BLAKEMAN, TAYLOR & CO., New York.

THE CAMERON STEAM PUMP, Also known as the "SPECIAL" PUMP, is the standard of excellence at home and abroad. For Price Lists, address CAMERON PUMP WORKS, Foot East 23d Street, New York.

Mowry Car & Wheel Works, MANUFACTURERS OF CARS AND CAR WHEELS of all descriptions, wheels and Axles, Chilled Tires, Engine, Car and Bridge Castings, of any pattern, furnished to order at short notice.

SHEPARD'S CELEBRATED \$50 Screw Cutting Foot Lathe. Foot and Power Lathes, Drill Presses, Scrolls, Circular and Band Saws, Saw Attachments, Chucks, Mandrels, Twist Drills, Dogs, Calipers, etc.

Wood-Working Machinery, Such as Woodworth Planing, Tonguing, and Grooving Machines, Danfel's Planers, Richardson's Patent Improved Tenon Machines, Mortising, Moulding, and Re-Saw Machines, and Wood-Working Machinery generally.

BOGDARDUS' PATENT UNIVERSAL ECCENTRIC MILL. For grinding Bones, Ores, Sand, Old Crucibles, Fire Clay, Guanos, Oil Cake, Feed, Corn, Corn and Cob, Tobacco, Snuff, Sugar, Salts, Roots, Spices, Coffee, Coconut, Flaxseed, Asbestos, Mica, etc.

Pyrometers. For showing heat of Ovens, Hot Blast Pipes, Boiler Flues, Superheated Steam, Oil Stills, etc.

BOILER COVERINGS. SAVE 10 TO 20 PER CENT. THE CHALMERS-SPENCE CO., Foot East 9th St., New York.

Model Engines. Complete sets of CASTINGS for making small Model steam Engines 1 1/2 in. bore, 3 in. stroke, price, \$4; ditto 2 in. bore, 4 in. stroke, price, \$10, same style as cut.

Woodward Steam Pumps and Fire Engines. G. M. WOODWARD, 76 and 78 Centre Street, New York.

Pond's Tools, Engine Lathes, Planers, Drills, &c. DAVID W. POND, Worcester, Mass.

ELEVATORS. HAND POWER and HYDRAULIC FREIGHT & PASSENGER SHAFTING FULLEYS & HANGERS.

JOSEPH C. TODD, ENGINEER and MACHINIST. Flax, Hemp, Jute Rope, Oakum and Bagging Machinery, Steam Boilers, etc.

D.M. FERRY & CO'S ILLUSTRATED SEED CATALOGUE for 1879. Will be mailed FREE to all applicants. It contains 2 colored plates, 500 engravings, about 150 pages, and full descriptions, prices and directions for planting over 1200 varieties of Vegetable and Flower Seeds, Plants, Roses, Etc.

Holly's Improved Water Works. Direct Pumping Plan. Combines, with other advantages, over older systems, the following: 1. Secures by variable pressure a more reliable water supply for all purposes.

Automatic Fire and Water Alarms. FOR SALE - Rights to introduce the above patents of this company in England, France, Canada, or in the States and Cities throughout the United States.

Send for Catalogue of the FIRMENICH SAFETY STEAM BOILER, For burning smoke and all gases from coal and all kinds of fuel. Requires no cleaning of Soot or Ashes.

MACHINISTS' TOOLS. NEW AND IMPROVED PATTERNS. Send for new illustrated catalogue. Lathes, Planers, Drills, &c. NEW HAVEN MANUFACTURING CO., New Haven, Conn.

Every Man His Own Printer! THE \$3 Press. Prints labels, cards, etc. (Self-inker \$5) 9 Larger sizes for business, pleasure, young or old. Catalogue of Presses, Type, Etc., for 2 stamps. KELSEY & Co. Meriden, Conn.

ICE AT \$1.00 PER TON. The PICTET ARTIFICIAL ICE CO., LIMITED, Room 51, Coal and Iron Exchange, P. O. Box 3063, N. Y.

Steel Castings, From 4 to 10,000 lbs. weight, true to pattern, sound and solid, of unequalled strength, toughness and durability.

TELEPHONE WORKS 1 mile. Circulars free. HOLCOMB & CO., Mallet Creek, Ohio.

CARY & MOEN STEEL WIRE OF EVERY DESCRIPTION & STEEL SPRINGS. NEW YORK CITY, 234 W. 29 ST.

Gold, Silver, and Nickel Plating. A trade easily learned. Costs little to start. The Electro Plater's Guide, a 72 page book, sent for 3 stamps.

PARTNER WANTED TO TAKE A HALF interest in a Foundry, Machine Shop, and Planing Mill. Established in 1869. Best locality in the North-west.

PATENTS at AUCTION. Regular Monthly Sales by George W. Keeler, Auctioneer. For terms, address NEW YORK PATENT EXCHANGE, 67 Liberty Street, New York.

LEFFEL WATER WHEELS. With recent improvements. Prices Greatly Reduced. 7000 in successful operation.

MINING MACHINERY. Engines, Boilers, Pumps, Coal and Ore Jigs, Dust Burning Appliances. Drawings and advice free to customers. Jeaneville Iron Works (J. C. Hayden & Co.). Address HOWELL GREEN, Supt., Jeaneville, Luzerne Co., Pa.

Lathes, Planers, Shapers Drills, Bolt and Gear Cutters, Milling Machines. Special Machinery. E. GOULD & EBERHARDT, Newark, N. J.

The George Place Machinery Agency Machinery of Every Description, 121 Chambers and 103 Reade Streets, New York.

WOOD WORKING MACHINERY. PLANING, MATCHING, MOLDING, MORTISING, TENONING, CARVING, BAND & SCROLL SAWS, UNIVERSAL WORKERS, VARIETY WOOD &c. J. J. JENNY & CO. CINCINNATI, O. U.S.A.

MACHINERY AT VERY LOW PRICES. 2d hand Lathes, Drills, Planers, Hand Tools for Iron Work, new Woodworth Planing Machines, Resawing, Tenoning, Moulding Machines, Scroll Saws, Portable Steam Engine. Jos. R. Blossom, Ass't, Matteawan, N. Y.

OTIS' SAFETY HOISTING Machinery. OTIS BROS. & CO., No. 948 Broadway, New York.

THE TANITE CO. STROUDSBURG, PA. EMERY WHEELS AND GRINDERS. GEO. PLACE, 121 Chambers St., New York Agent.

ROCK DRILLING MACHINES AND AIR COMPRESSORS. MANUFACTURED BY BURLEIGH ROCK DRILL CO. SEND FOR PAMPHLET. FITCHBURG, MASS.

TO ADVERTISERS! We fill orders for the insertion of advertisements in the newspapers of the United States and Dominion of Canada. To furnish advertisers with reliable information concerning newspapers and their rates, and thus enable the most inexperienced to select intelligently the mediums best adapted to any particular purpose, we issue SEMI-ANNUAL EDITIONS OF AYER & SON'S MANUAL FOR ADVERTISERS.

PATENT COLD ROLLED SHAFITING. The fact that this shafting has 75 per cent. greater strength, a finer finish, and is truer to gauge, than any other in use renders it undoubtedly the most economical.

BOLT CUTTERS. Schlenker's Automatic Bolt Cutters and Screw Cutting Machines. HOWARD IRON WORKS Buffalo, N. Y.

The Columbia Bicycle, Made by THE POPE M'FG CO., 89 Summer Street, Boston. A practical road machine, easy to learn to ride, and when mastered one can beat the best horse in a day's run over an ordinary road.

CAVEATS, COPYRIGHTS, TRADE MARKS, ETC. Messrs. Munn & Co., in connection with the publication of the SCIENTIFIC AMERICAN, continue to examine Improvements, and to act as Solicitors of Patents for Inventors.

IN THIS LINE OF BUSINESS they have had OVER THIRTY YEARS' EXPERIENCE, and now have unequalled facilities for the preparation of Patent Drawings, Specifications, and the Prosecution of Applications for Patents in the United States, Canada, and Foreign Countries.

WE SEND FREE OF CHARGE, on application, a pamphlet containing further information about Patents and how to procure them; directions concerning Trade Marks, Copyrights, Designs, Patents, Appeals, Reissues, Infringements, Assignments, Rejected Cases, Hints on the Sale of Patents, etc.

Foreign Patents. - We also send, free of charge, a Synopsis of Foreign Patent Laws, showing the cost and method of securing patents in all the principal countries of the world. American inventors should bear in mind that, as a general rule, any invention that is valuable to the patentee in this country is worth equally as much in England and some other foreign countries.

Copies of Patents. - Persons desiring any patent issued from 1836 to November 26, 1867, can be supplied with official copies at reasonable cost, the price depending upon the extent of drawings and length of specifications.

Any patent issued since November 27, 1867, at which time the Patent Office commenced printing the drawings and specifications, may be had by remitting to this office \$1.

A copy of the claims of any patent issued since 1836 will be furnished for \$1. When ordering copies, please to remit for the same as above, and state name of patentee, title of invention, and date of patent.

A pamphlet, containing full directions for obtaining United States patents sent free. A handsomely bound Reference Book, gilt edges, contains 140 pages and many engravings and tables important to every patentee and mechanic, and is a useful hand book of reference for everybody. Price 25 cents, mailed free.

Address MUNN & CO., Publishers SCIENTIFIC AMERICAN, 37 Park Row, New York.

BRANCH OFFICE - Corner of F and 7th Streets, Washington, D. C. THE "Scientific American" is printed with CHAS. T. JENNY'S PATENT TYPE AND GALLEY. Tenth and Lombard Sts., Philadelphia, and 60 Gold St., New York.