

CHICHESTER WATER WORKS.

The prominent position now taken among engineering questions by those of water supply, especially to small places, will make the following illustrated description of Chichester water works of considerable interest to our readers. The works contain several features of engineering interest, and are such as are suitable for a large number of towns.

The source of supply is a well sunk in the chalk, adjacent to a powerful spring one and a quarter miles west of the city. The exact position of the well was determined by the certainty of an adequate supply being obtainable near the spring, while its location so far from Chichester was fixed with a view to avoid the contaminated water inclosed in the geological basin over which the city stands.

The works consist of a pumping station at the source of supply, a main pipe, 2½ miles long, passing through the city to a service reservoir and tower, and four miles of distribution pipes. They were designed to supply eventually a population of 10,000 persons with 20 gallons per head per day. At the pumping station the sinking of the well was commenced with wooden cylinders 6 feet diameter inside the curbs, for a depth of 17 feet, after which it was continued with wrought iron cylinders 5 feet 8 inches inside diameter. The cylinders were 9 feet long, connected by angle irons 3 inches by 3 inches. The plates were ¾ inch thick, and the rivets were countersunk on the outer side. The wooden cylinders were lined with brickwork in cement, and the junction between the brickwork and iron was securely calked with oak wedges. A foundation for the superstructure of the engine house and the engines was secured by a dome of cement concrete.

The engines and pumps are in duplicate, each designed to raise on trial 10,000 gallons per hour against a head of 200 feet, with a consumption of 3½ lbs. of Welsh coal per horse power estimated by the water lifted, and in actual work they each lift 11,500 gallons per hour against a head of 160 feet, with a consumption of 4 lbs. per horse power.

The engine is horizontal and of the usual compound type, with the high pressure cylinder toward the crank and in front of the low pressure cylinder. The diameter of the high pressure cylinder is 9½ inches, and that of the low pressure is 18 inches, and the stroke is 2 feet.

On the end of the crank shaft is placed a disk, from which the pump is driven direct from the main shaft. The pump is of the plunger and bucket type. The diameter of the plunger is 8 inches, that of the bucket 11 inches, and the stroke 1 foot 6 inches. Steam is supplied from two Cornish boilers of 4 feet diameter and 14 feet in length, with one flue in each of 2 feet 2½ inches diameter. The speed of the engines was designed to be 30 strokes per minute, and in actual work they run from 28 to 35 strokes per minute.

It is proposed to check the engines more by employing a slide valve on the steam pipe, which is to be kept open by the pressure of the column of water, and to be instantly closed by a spring when the pressure is relaxed.

The reservoir was designed to hold 100,000 gallons only, though provision was made for doubling its capacity event-

ually if necessary. It is 10 feet deep, and is built on a subsoil of wet sand and gravel, of Portland cement and gravel concrete (1 to 6), rendered with cement and sand (1 to 3), and floated on the inside surfaces with cement and sand (1 to 1). The main is taken through the wall so as to project about 6 feet into the reservoir. This projection was bedded in and surrounded with cement, and then built round with a block of concrete, having all its outer surfaces rendered in cement. All angles and corners were run with a fillet of cement, and thus a completely watertight job was effected

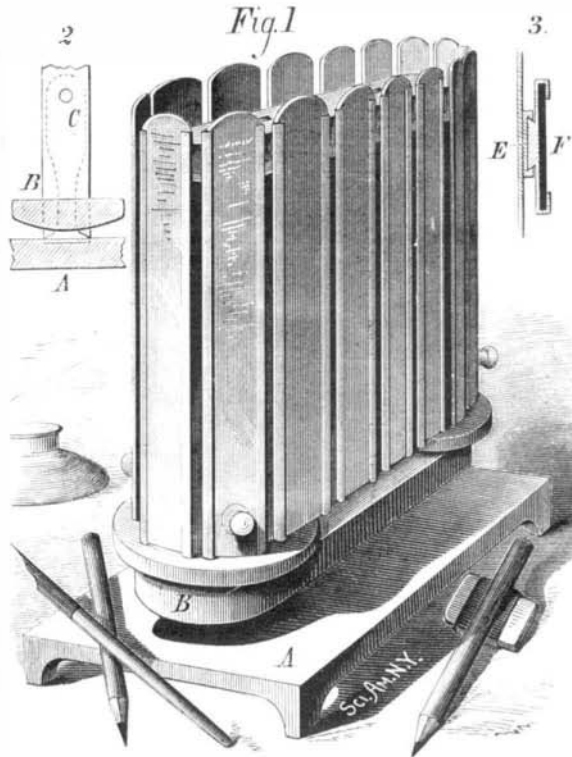

ALBER'S REVOLVING INDEX.

without puddle. The whole was arched over in brickwork, and covered with an earth embankment.

The highest ground available for the reservoir is only 60 feet above Chichester Cross, which may be taken as the average available head at the reservoir for almost all the district to be supplied. This head is increased to about 100 feet at the Cross when the pumps are at work, but inasmuch as the supply to the higher parts of the district would thus have depended on the pumps, and would have been intermittent and uncertain, a high level service was arranged by which a cistern is filled daily for each consumer requiring it, and a tank at the high level is always kept full and available for the extinction of fire.

To effect this, instead of a stand pipe, the tower, shown in

the engraving, was built with a tank at the top 40 feet higher than the reservoir, into which, when a valve on the main at its base is closed, the water rises up an 8 inch pipe and through a self-closing 8 inch valve seated in the bottom of the tank. The ordinary outlet from the tank being only through the overflow at the top, and thence into the reservoir, the tank is always kept full. The high service cisterns of the consumers are filled from the rising main, which has thus an additional 40 feet of head thrown upon it during the time that the engines are pumping into or over the tank for the purpose of filling the cisterns. The 8 inch self-closing valve in the bottom of the tank contains a 4 inch valve, which works with it on the same spindle, except when raised by a chain pulled from the chamber on the ground floor of the tower.

In case of a fire occurring when the pumps are not at work, and the pressure in the city is consequently low, the valve on the main at the bottom of the tower being closed, and the chain pulled, an extra head of 40 feet is thrown upon the pipes. The quantity of water in the tank is sufficient to supply one hose of the Metropolitan Fire Brigade pattern for about thirty minutes, and would allow time for getting out the fire engine and for starting the engines at the pumping station.

It is conceivable that such "fire reservoirs" might be applied on a large scale where high pressures would be otherwise difficult to obtain, and that they might be promptly brought into operation when needed by a telegraphic message to the man in charge.

The cost of the whole works, including a large sum spent in a parliamentary contest, amounts now to £14,500, and estimating that another £1,500 will be wanted to complete the distribution pipes, etc., for the supply of 10,000 persons, the total cost will be £16,000, equal to £1 12s. per head. The engineer of the company is Mr. Shelford, of Westminster, under whose direction the works were completed.

A NEW REVOLVING INDEX.

The accompanying engraving represents a revolving index recently patented by Mr. Lübke U. Albers, of Carthage, Ill. It is intended for the use of book-keepers and others requiring a ready means of referring to different names or items contained by the index.

To the center of the base, A, is attached a standard, C, which passes through the lower bar, B, of the frame that supports the vertical rollers around which the endless belt, E, passes. To this belt are attached a number of strips of sheet metal, which are bent outward to form slides for receiving the strips, F, of sheet metal which contain the strips on which are written the names, number of page, etc. These strips have at their upper ends the alphabet, and several of the strips, F, have small knobs for convenience in turning the endless belt. The belt and its supports may be inclined at any desired angle, and the strips may be removed when filled and filed for future reference. The advantages of this device will be apparent to those who require an index. It certainly will effect a considerable saving in time. For further particulars address the inventor as above.

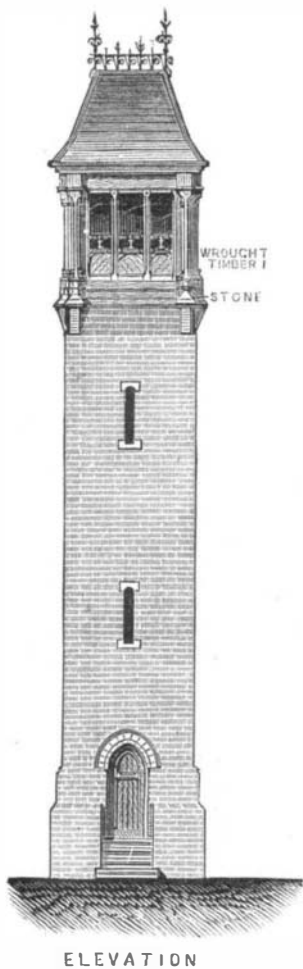

ELEVATION

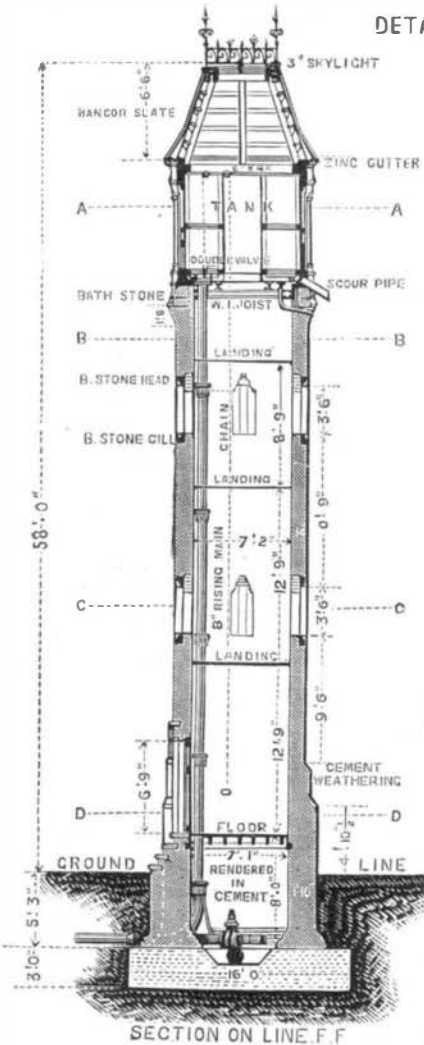

SECTION ON LINE F.F.

DETAILS OF WATER TOWER

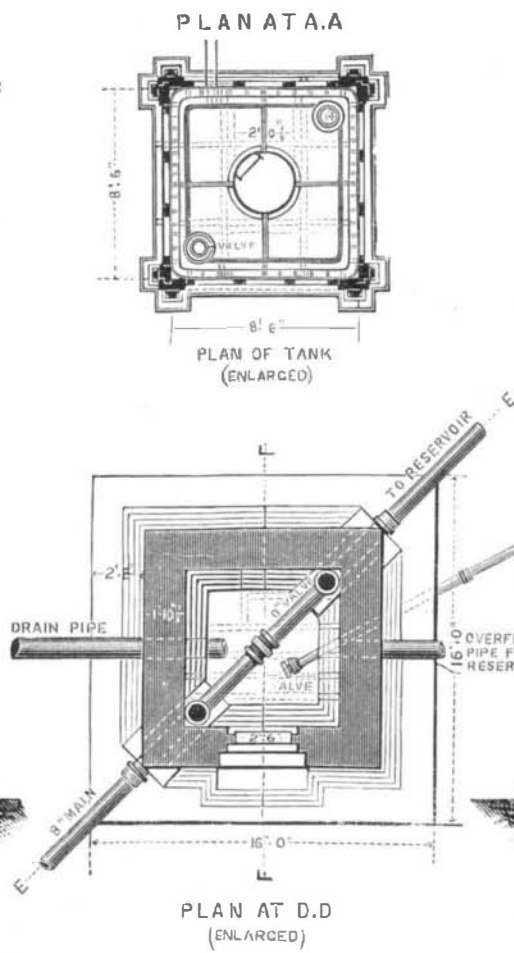

PLAN AT D.D. (ENLARGED)

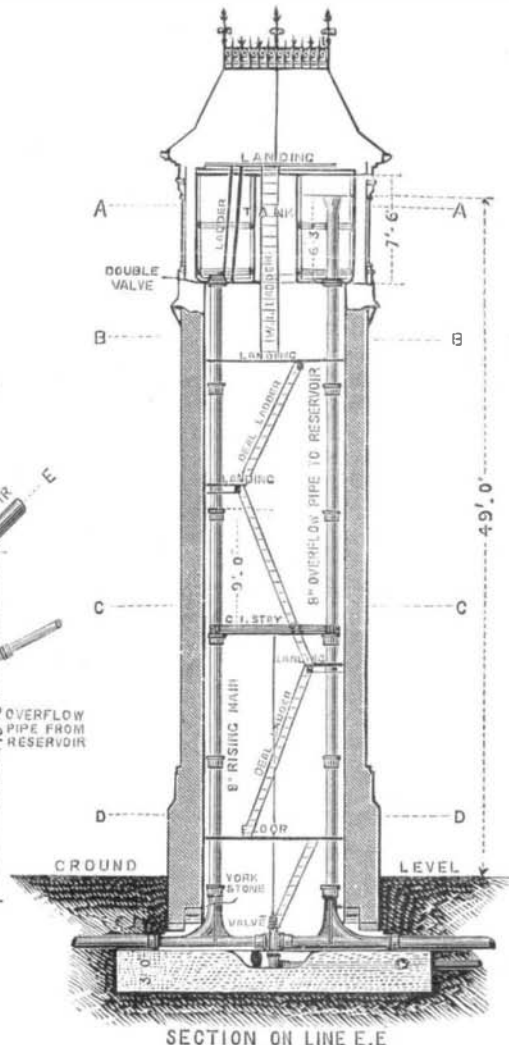

SECTION ON LINE E.E.

CHICHESTER WATER TOWER.