

DRILLING SQUARE HOLES.

To drill a square hole with a rotary motion at one operation may seem to many a novelty in mechanics, but Mr. J. Hall, of Chancery Lane, has obtained a patent for a method of accomplishing the feat. For this purpose he employs a three sided drill, either flat or fluted, which, in cross section, is of the form of an equilateral triangle. He makes the bottom or cutting edges of the drill perfectly flat, and three in number, each cutting edge extending from one of the outer corners to the center of the triangle. The proposed method of using such drills in an ordinary vertical drilling machine is as follows: A special drill chuck, forming part of the invention, is provided, and attached to the lower end of the drilling spindle. The chuck is constructed in such manner as to admit of the drill traveling automatically in a horizontal plane some little distance. This is ren-

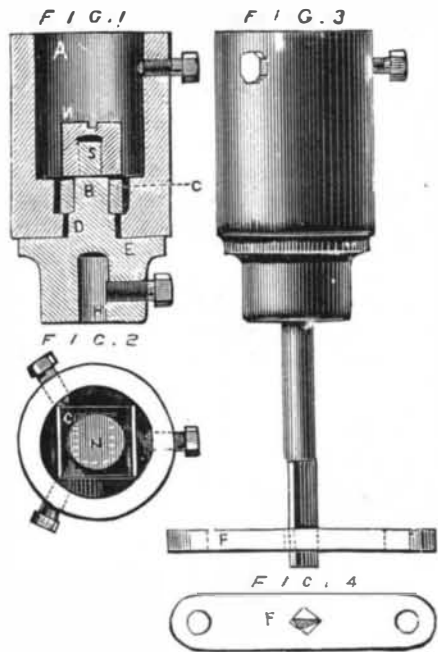

TOOL FOR DRILLING SQUARE HOLES.

dered necessary by the peculiar movement of the cutting edges of the drill, which does not operate or rotate on a fixed central point, but diverges somewhat in proportion to the size of the hole.

The drill chuck is constructed in the following manner: The upper part of the cavity of a metal cylinder is bored out circularly, so as to fit on to the drilling spindle, to which it is screwed by one or more screws. Below the circular bore a square recess is made, and below this latter, and coming well within the limits of the square recess, there is a circular hole passing through the end of the cylinder. The drill holder or socket is in a separate piece, the bottom portion of which is provided with a square or round recess for holding the shank or upper end of the drill, which is held firmly in its place by means of a set screw. The device is shown in the accompanying engraving, which we take from the *English Mechanic*. The upper part consists, first, of a screw, S, at the top, Fig. 1; secondly, of a square shoulder, B; thirdly, of a circular shoulder, D; and, fourthly, of another but much larger circular shoulder, E. Through the circular hole at the bottom of the hollow cylinder the upper portion of the drill holder is inserted until the large circular shoulder meets the bottom of such cylinder. A loose square collar, A (Figs. 1 and 2), provided with an oblong rectangular slot, is then placed within the cylinder and over the square above mentioned, above and on to which is screwed down a nut, N, from the inside of the cylinder. The loose square is of such thickness that when the nut is tightened down on to the square shoulder the loose collar is left to work freely. When this is done the drill holder will readily travel in a horizontal plane such distance as the play between two of the sides of the loose collar, and two of the sides of the square recess, in one direction, and in another direction the distance of the play between two of the sides of the small square shoulder of the drill holder and the ends of the rectangular slot in the loose collar. The horizontal travel or play is proportionate to the size of the hole to be drilled. Near to the lower end or cutting edges of the drill is fixed rigidly a metal guide bar or plate, F. The guide bar is provided with a square hole similar to the hole it is required to drill, the dimensions of the three sides of the drill being such that the distance from the base to the apex of the triangle, which such three sides form, is the same as of the sides of the square holes it is required to drill.

Mr. Hall prefers to make the guide bar of steel, which he hardens at that part where the guide hole is made. The method of operation is then as follows: The three sided drill being fixed in the self-adjusting chuck, the guide bar with the square guide hole therein rigidly fixed above the point where it is required to drill, the drilling spindle carrying the chuck drill is made to revolve, and is screwed or pressed

downwards, upon which the drill works downwards through the square guide hole, and drills holes similar in size and form to that in the guide. The triangular drill for drilling dead square holes may also be used without the self-adjusting drill chuck in any ordinary chuck, when the substance operated upon is not very heavy nor stationary; then, instead of the lateral movement of the drill, such lateral movement will be communicated to the drill by the substance operated upon.

Although the patentee only cites the case of a vertical drilling machine in connection with this invention, he declares that the specified improvements are equally applicable to lathes, ordinary braces, ratchet braces, and all other descriptions of drilling apparatus. In making oblong dead square cornered holes, either the substance to be operated upon must be allowed to move in one direction more than another, or the hole in the guide plate must be made to the shape required, and the drill chuck made to give the drill greater play in one direction. Fig. 1 shows a vertical section of the improved chuck, in which A is the hollow cylinder, which may be attached to any ordinary drilling machine; H is the drill holder; S is a screw; B is a square shoulder; D is a circular shoulder; E is a circular shoulder of a larger dimension; N is a screw nut for tightening on to the square shoulder, B, and the loose square collar. Fig. 2 is a plan view of Fig. 1. Fig. 3 is an elevation of the improved chuck; C showing the three sided drill and the guide bar, F, complete. Fig. 4 is a plan of the guide bar, F, showing the three sided drill in cross section.

Indications of Progress.

While Paris has been reveling in excess of light, and, according to many, paying pretty heavily for it, we, says the *Electrician* (London) in issue of October 16th, have been waiting the results of the experiments. However, amidst the confusion of cries, there seems to be a general consensus of opinion that electricity is the best method of lighting under certain circumstances. This being the case, efforts are being made to supply any demand that may arise. No less than three electric light companies have been registered within the last few days, with a total capital of over £200,000. The British Electric Light Company, promoted by Mr. E. J. Reed, takes up Rapiéff's patent, and is patronized by the *Times*. The Electric Lighting Company, promoted by Mr. Hollingshead, is to work the Lontin system, and is patronized by the frequenters of the Gayety, and all who walk through the Strand during certain portions of the evening. These two have a nominal capital of £100,000 each. The Sun Electric Light Company is the third and last, with a capital of £5,000 only. Mr. Strickland is the promoter, and the company is formed for the development of the Harrison system, about which little has been publicly said, but which private report mentions in the highest terms. The candles are said to surpass the Jablockhoff, and the division of the light seems to anticipate Mr. Edison. The public will soon be able to judge the value of these reports for themselves, as arrangements are being made to use the light on a very large scale.

RUSSIAN POTTERY.

We present engravings of two examples of unglazed Rus-



RUSSIAN POTTERY.

sian pottery of quaint design. It resembles in texture and material the old black Wedgwood ware so much admired by connoisseurs.

Practical Education in Russia.

In a letter from the Paris Exhibition, Col. Forney, of the *Philadelphia Press*, remarks that while American progress has astonished Europe, yet "Germany, Switzerland, and France have methods and systems that deserve to be studied. Even Russia may be a model for all of us. Yesterday I saw some Russian machinery at the Exhibition; and my admiration increased as I was told that much of this exquisite work was made by the youth, many of them sons of the best

families, sent into the machine shops to learn trades as a part of their education. There was no alternative; they were compelled to pass this ordeal. The government is the master, and young Russia must obey; and now obedience becomes a delight; and it is as much the fashion to finish a practical education in this way, as formerly it was the fashion to pass through a school, or an academy, or college, for the easy acquisition of superficial accomplishments."

NEW MORTISING MACHINE.

A novel form of mortising machine, the invention of Mr. Wm. W. Green, Jr., of Chicago, Ill., is shown in the accompanying engraving. In this machine the usual vertically reciprocating chisel is replaced by an endless chain consist-

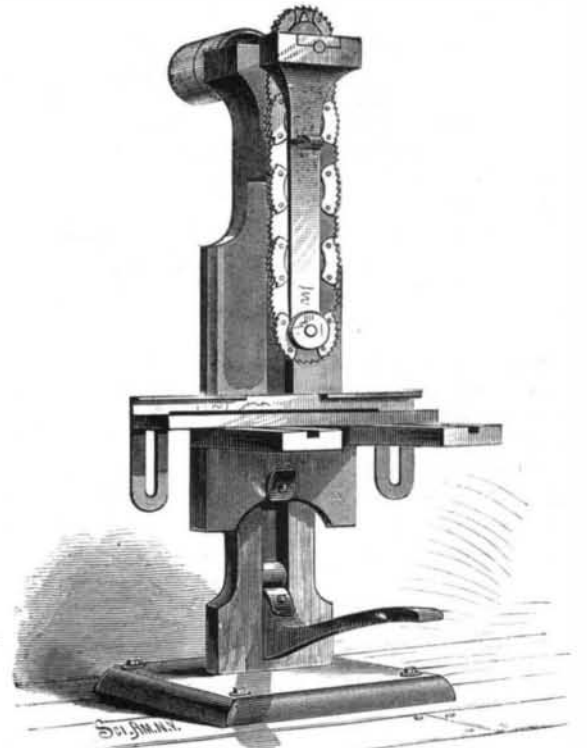

GREEN'S MORTISING MACHINE.

ing of saw sections jointed together and running over two pulleys, the upper one of which is spurred, and acts as a driver. The lower pulley is journaled in the end of a vertical arm, which is of the same thickness as the endless chain saw.

The vertically sliding table which supports the work is of the usual description; but it is raised by very simple means. To the pedal is attached a strap, which passes under one pulley and over another, and is attached to the table. A downward pressure on the pedal raises the latter and carries the work up to the cutter. The width of the mortise may be varied by using pulleys of different diameters.

Recent Engineering Inventions.

Mr. William P. Barclay, of Virginia City, Nev., has patented an improvement in Hydraulic and Wire Rope Pumping Systems. In pumping machinery, such as is commonly employed in freeing mines from water, heavy rods of wood, jointed and bolted together by iron plates, are used. These rods, to have the requisite strength, become excessively heavy, requiring counterbalancing, thus throwing into the pumping apparatus a quantity of heavy material that requires to be oscillated at each stroke of the pumps, thereby consuming a great amount of power and rendering the action of the pump slow. By this improvement these difficulties are overcome and the pumping is effected economically. This invention employs as many force pumps in the mine or shaft as may be required, placing them one above the other at suitable distances apart. These pumps are provided with the usual inlet and discharge valves placed one above the other.

Mr. Frederick Bowen, of Barnhart's Mills, Pa., has patented an improved Pump for Oil Wells. The object of this invention is to provide for withdrawing and replacing the packing of the pump plunger in oil or artesian wells without disturbing the tubing or valves. It consists in the arrangement of the upper valves in connection with the cell containing the stuffing box, and in the manner of securing and removing the packing ring of Babbitt metal.

Comstock Silver Lodes.

The survey of the silver mines situated on the Comstock lode was carried on in 1877 by Professor I. A. Church, of Lieut. Wheeler's party. The character of the vein was carefully mapped from one thousand to two thousand feet deep. The heat varied from 84° Fah. in old drifts to 116° in freshly opened ones. The source of the heat is, it is believed by those in charge of the works, ascertained to be the decomposition of the rocks under the agency of atmospheric influences. This was observed of the thick sheets of lava