

EDISON'S MICRO-TASIMETER.

The latest of Edison's inventions, and perhaps the most interesting to physicists, is his micro-tasimeter, or measurer of infinitesimal pressure.

The thermopile, hitherto foremost among delicate indicators of changes of temperature, must now be consigned to the rear ranks, and the radiometer, which exhibits the motive power of the most subtle of forces, must retire in favor of an instrument that can weigh that force.

The micro-tasimeter is the outcome of Professor Edison's experiments with his carbon telephone. Having experimented with diaphragms of various thicknesses, he ascertained that the best results were secured by using the thicker diaphragms. At this stage he experienced a new difficulty. So sensitive was the carbon button to changes of condition, that the expansion of the rubber telephone handle rendered the instrument inarticulate, and finally inoperative. Iron handles were substituted with a similar result, but with the additional feature of musical and creaky tones distinctly audible in the receiving instrument. These sounds Professor Edison attributed to the movement of the molecules of iron among themselves during expansion. He calls them "molecular music." To avoid these disturbances in the telephone, the handle was dispensed with; but it had done a great service in revealing the extreme sensitiveness of the carbon button, and this discovery opened the way for the invention of the new and wonderful instrument.

The micro-tasimeter is represented in perspective in Figs. 1 and 2, in section in Fig. 3, and the plan upon which it is arranged in the electric circuit is shown in Fig. 4.

The instrument consists essentially in a rigid iron frame for holding the carbon button, which is placed between two platinum surfaces, one of which is fixed and the other movable, and in a device for holding the object to be tested, so that the pressure resulting from the expansion of the object acts upon the carbon button.

Two stout posts, A, B, project from the rigid base piece, C. A vulcanite disk, D, is secured to the post, A, by the platinum-headed screw, E, the head of which rests in the bottom of a shallow circular cavity in the center of the disk. In this cavity, and in contact with the head of the screw, E, the carbon button, F, is placed. Upon the outer face of the button there is a disk of platinum foil, which is in electrical communication with the battery. A metallic cup, G, is placed in contact with the platinum disk to receive one end of the strip of whatever material is employed to operate the instrument.

The post, B, is about four inches from the post, A, and contains a screw-acted follower, H, that carries a cup, I, between which and the cup, G, is placed a strip of any substance whose expansibility it is desired to exhibit. The post, A, is in electrical communication with a galvanometer, and the galvanometer is connected with the battery. The strip

of the substance to be tested is put under a small initial pressure, which deflects the galvanometer needle a few degrees from the neutral point. When the needle comes to rest, its position is noted. The slightest subsequent expansion or contraction of the strip will be indicated by the movement of the galvanometer needle. A thin strip of hard rubber, placed in the instrument, exhibits extreme sensitiveness, being expanded by heat from the hand, so as to move through several degrees the needle of a very ordinary galvanometer, which is not affected in the slightest degree by a thermopile facing and near a red hot iron. The hand, in this experiment, is held a few inches from the rubber strip. A strip of mica is sensibly affected by the heat

of the hand, and a strip of gelatin, placed in the instrument, is instantly expanded by moisture from a dampened piece of paper held two or three inches away.

For these experiments the instrument is arranged as in Fig. 2, but for more delicate operations it is connected with a Thomson's reflecting galvanometer, and the current is regulated by a Wheatstone's bridge and a rheostat, so that the resistance on both sides of the galvanometer is equal, and the light-pencil from the reflector falls on 0° of the scale. This arrangement is shown in Fig. 1, and the principle

is illustrated by the diagram, Fig. 4. Here the galvanometer is at *g*, and the instrument which is at *i* is adjusted, say, for example, to ten ohms resistance. At *a*, *b*, and *c* the resistance is the same. An increase or diminution of the pressure on the carbon button by an infinitesimal expansion or contraction of the substance under test is indicated on the scale of the galvanometer.

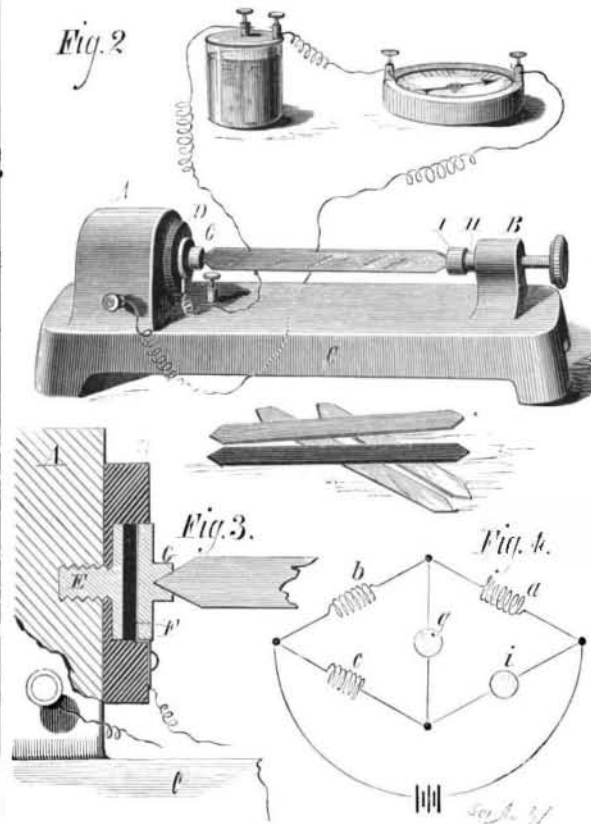

The carbon button may be compared to a valve, for, when it is compressed in the slightest degree, its electrical conductivity is increased, and when it is allowed to expand it partly loses its conducting power.

The heat from the hand, held 6 or 8 inches from a strip of vulcanite placed in the instrument—when arranged as last described—is sufficient to deflect the galvanometer mirror so as to throw the light-beam completely off the scale. A cold body placed near the vulcanite strip will carry the light-beam in the opposite direction.

Pressure that is inappreciable and undiscoverable by other means is distinctly indicated by this instrument. Professor Edison proposes to make application of the

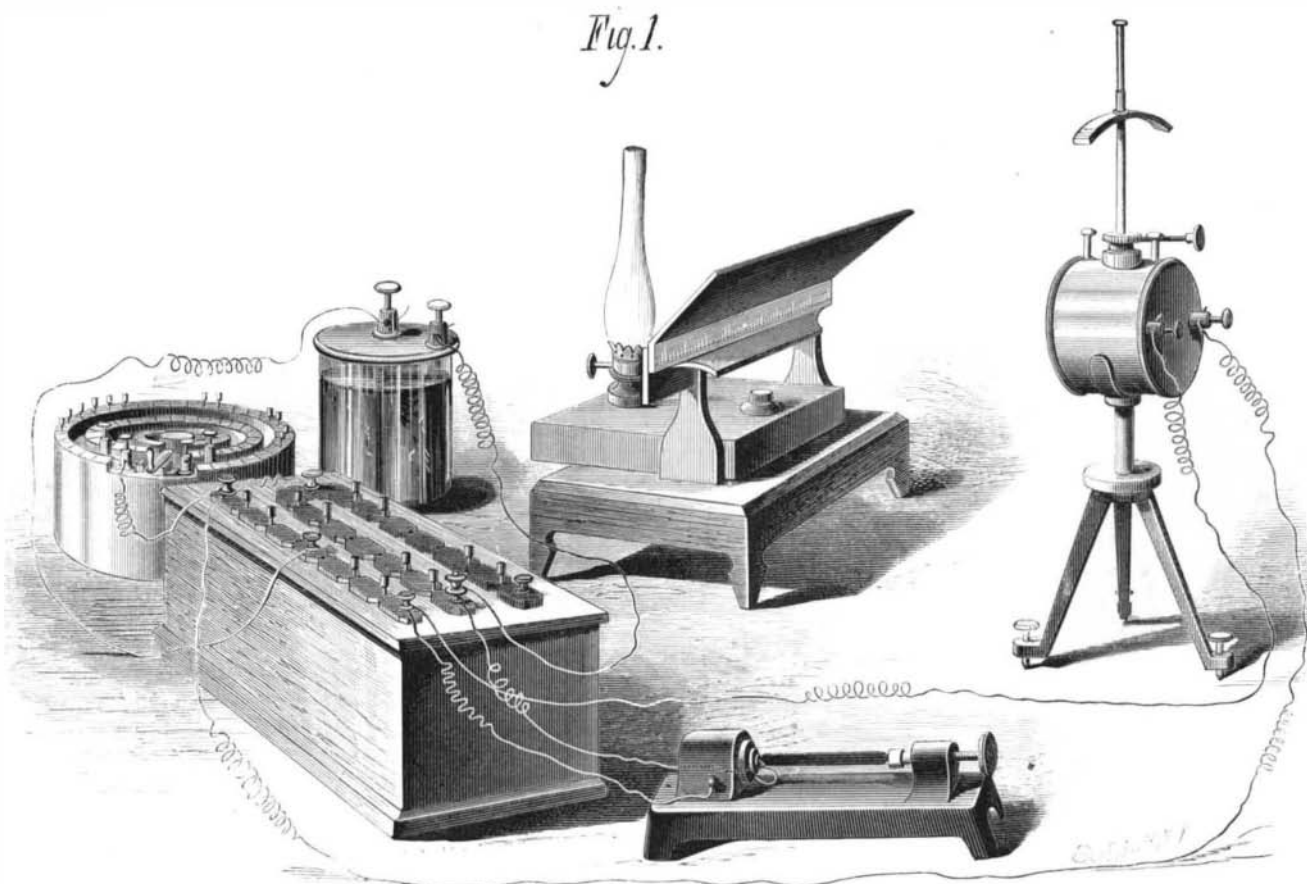

EDISON'S MICRO-TASIMETER.

principle of this instrument to numberless purposes, among which are delicate thermometers, barometers, and hygrometers. He expects to indicate the heat of the stars and to weigh the light of the sun.

NOTE BY PROFESSOR EDISON.

The heat measurer was described and experiments shown to Professor Langley, the well known astronomer of the Alleghany Observatory, some six months ago. On his suggestion at the time, that it ought to be worked up as a very valuable boon to science, especially in the line he was

investigating (that is, measuring the heat of the stellar spectra), I tried many experiments with it and devised the form given. This apparatus was described to various members of the National Academy of Sciences, held at Washington, April 17, 18, and 19, 1878, and the *Washington Star* and *Union* newspapers published then gave a description of the instrument. Copies of these papers were at once mailed to William H. Preece, Professor Scheelen, Count Du Moncel, and other physicists in Europe.

A River Reversed.

A natural river begins in countless little runlets, which unite in a network of larger streams, to unite in their turn in still larger ones, until a strong current receives the united flow from all. The sunless stream that supplies a great city, like New York, reverses all this. It begins at a single stream and ends at a million outlets. The network of pipes through which the Croton is delivered aggregates a length of 440 miles, and the daily flow averages 85,000,000 gallons.

GOOD WORK FROM CHEAP PATENTS.

It is not long since a prominent Englishman urged as an objection to cheap patents the comical plea that they gave an unnatural impulse to the inventive faculty, thereby fostering a preference for mere cleverness over honest work. As an awful example he pointed to the United States, "where the factitious value attached to inventions has tended to produce an almost total sacrifice of solid workmanship to flimsy ingenuity." A very pretty comment on this charge may be found in the explanation given in the leading English papers of the secret of the dangerous character of American competition in cottons and other manufactures. The danger lies, they admit, not so much in the cheapness of American goods as in their superior quality and finish. Where they are known, American cottons are preferred to those of England in the great markets of the East, even at a higher price, because they are honestly made. The *Saturday Review* attributes the decline and threatened loss of England's trade in the East as much to "the fraudulent folly of English manufacturers, who have lost their customers by palming off on them adulterated goods," as to the natural advantages of American manufacturers. In like manner the *London Times* attributes the increase of American manufactures, and their successful competition with those of England, to their superiority as well as to genuine domestic advantages in the processes of manufacture. A Swiss commissioner to the Philadelphia Exhibition writes to his countrymen: "Have you ever compared a rake, a spade, a knife, a hatchet, made in America, with tools made here? How much is Europe left behind! While our constructors aim generally at products heavy, massive, solid, in appearance, and save rather in the quality of the metal than on the weight, American workmanship is light, pleasing to the eye, and employs almost exclusively good material."

At the exposition of objects of art at Munich there was nothing in cast iron which could be compared with a stove which he had brought from America. "Not merely for the good quality of the casting, but also in the ornamentation." Again, he says: "Who does not know American sewing machines? And who has not already become satisfied, even when machines of the same kind are made in Europe in enormous quantities, that the somewhat higher price of the American machines is largely compensated for by their construction, their solidity, and their convenience?" So far from finding in American products

any sacrifice of solid workmanship to flimsy ingenuity, this critical observer pronounces them generally "handsome, solid, practical, light, and of good material," and the verdict of buyers, the world over, confirms his testimony.

NEW WHEEL TIRE.—A new wheel tire has been recently invented. It consists in passing around the usual iron tire a rubber tire, and around this again an iron tire made in sections, so that each section may yield inward as the weight comes upon it. It is said to lessen noise, jarring, and wear.