

an improvement on the ordinary form of Squib used in blasting, and consists in an interior explosive alarm device, which indicates that the squib is doing its work, and thus gives warning that the charge is about to explode.

Mr. James Forsyth, of New York city, has made some improvements in Roller Skates, by which the latter may be guided forward, backward, or diagonally in any direction by tipping the foot, without rocking or oscillating.

A Process of Manufacturing Oil from Organic Substances, such as pitch pine, cotton seed, sassafras, etc., which consists in injecting steam and carbonic acid gas into the retort containing the material and heated to a high temperature, has been invented by Mr. D. M. Buie, of Wilmington, N. C.

A Combination Fuse for Projectiles has been patented by MM. Eduard Rubin and August Fornerod-Stadler, of Thun, Switzerland. The invention consists in the combination of a percussion fuse, which is ignited by the sudden force imparted to the shell at the moment of firing, with a double-graduated ring fuse and a powder chamber. There is also a second percussion fuse which is thrown into action when the shell strikes an object.

Mr. John Cottner, of New York city, has patented an improved Trunk, the lid of which has a hinged receptacle divided by a horizontal partition, a drawer, hat box space, looking glass (hinged and protected by a cushion), a secret jewel receptacle, and a hinged desk, all arranged compactly.

In a new Fire Escape, the invention of Mr. Geo. Kenyon, of Springfield, Ill., the new features are essentially as follows: A hand device is added for operating the brake band of a pulley, upon which the escape rope is reeled, and it consists of a fixed handle, spring, and movable handle, the latter receiving the rings of the brake band. The pulley and brake descend with the person, the upper end of the rope being secured by a spring snap hook to a staple or other support.

A Torpedo for use in oil wells has been invented by Mr. J. J. Boyer, of Lamartine, Pa. It is so constructed as to be capable of being exploded at any desired depth, but not under fluid; and it consists of a torpedo shell or case, with bottom socket for inserting an anchor, solid anvil, and interior guide tube for a weighted drop wire, which is also guided in a top guard of supporting balls. The anvil forms a support for percussion caps, which are exploded by lowering the drop wire.

Mr. S. O. Parker, of Littleton, N. H., has invented a Glove, in which each finger is made in one piece, with the seam on the back.

Mr. G. F. Whitaker, of Hudson, Mass., has invented an improvement in Wagon Tops, which consists in so arranging rear or side doors with spring catches and frames that loss of contents by jarring out, thefts, entrance of insects, dust, etc., may be prevented, at the same time allowing convenient access to the interior, and furnishing a cover for the driver while standing at the door.

**A NEW MODE OF DITCHING.**

We illustrate herewith a ditching apparatus, which cuts a subterranean flue and also packs the soil around the same so as to convert it into a pipe. Upon the lower end of the branched standard, E, is formed a cylindrical head, through which passes a rod, F. To the forward end of the rod is attached a cutter, G, which is made with wings upon its sides and top, so that it may be drawn easily through the ground. The rear end of this cutter is recessed to receive the cutter, H, which is placed upon the rod, F, between the cutter, G, and the standard, E. The cutter, H, is made slightly conical in form and with spiral corrugations upon its sides, which ribs make about one third of a turn and are formed with sharp edges, so as to cut the soil and press it upward and sidewise as the cutter is revolved by the pressure of the soil. Upon the rod, F, in the rear of the standard, E, is placed the cutter and packer, I. This, for a little more than half its length, is made slightly conical, and is ribbed spirally so as to cut the soil and press it upward and sidewise. The rear part of the cutter and packer, I, is made slightly conical and smooth so as to pack the soil and thus form a flue. To the rear end of the beam, A, is attached a water box, J, from the bottom of which a small tube, K, passes down along the rear edge of the standard, E, and terminates in a sprinkler at the forward end of the cutter and packer, I, to moisten the soil, so as to form an arch or tile out of the soil itself as it is worked and packed.

This device was patented through the Scientific American Patent Agency, April 17, 1877, by Mr. W. W. Snyder, of Martinsville, Ohio.

**A New Lubricating Material for Belts.**

Several correspondents have asked us to name some good material that will serve to prevent belts from slipping, which will be both cheap and efficient. Mr. John D. Parker, agent of the Union Lubricator Manufacturing Company's Lubricator, of No. 6 Haymarket square, Boston, calls our attention to that material, and sends us a testimonial from a

well known millwright, who states that the lubricator renders leather belts soft and pliable and causes them to carry unusual loads without slipping. The writer of this opinion has had large experience, and those of our readers who are troubled with slipping belts may find it to their interest to adopt the same means, which he states he has always used "with complete success."

**NEW APPARATUS FOR MEASURING THE VAPORIZING HEAT OF LIQUIDS.**

The annexed illustration, from *Les Mondes*, represents a new device by which the total heat given off by a liquid between

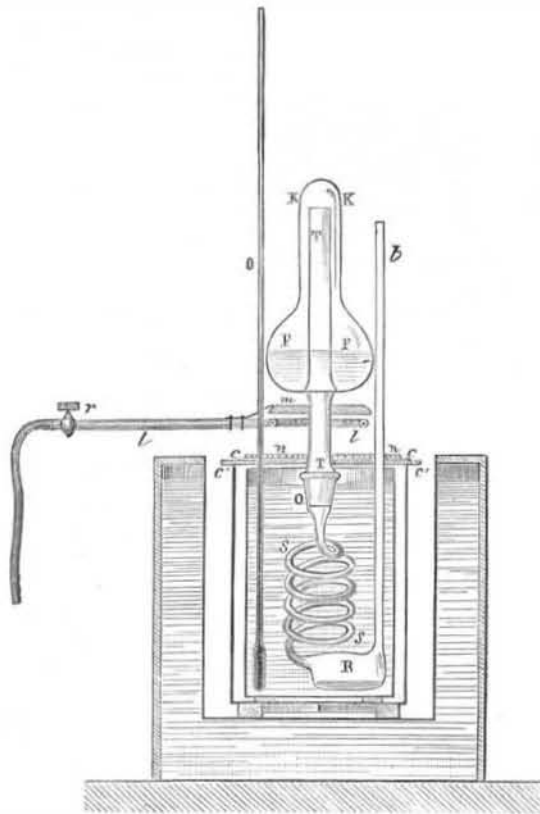

LIQUID CALORIMETER.

vaporization and the normal temperature is accurately measured. FF is a flask, the neck, KK, of which is hermetically sealed. Through this passes a vertical tube, T, which extends a few inches below the bottom and connects with a worm, O S S R, which is plunged in a calorimeter. Between the flask and the latter is a thin sheet of pasteboard, c, and a plate of wood, o (serving as screens and pierced for the passage of the tube, T), a piece of wire gauze, n, a circular lamp, l, and the sheet of wire gauze, m.

The flask being previously weighed, first singly and then filled with liquid, and the lamp being lit during the first period of the operation in which the temperature of the liquid is

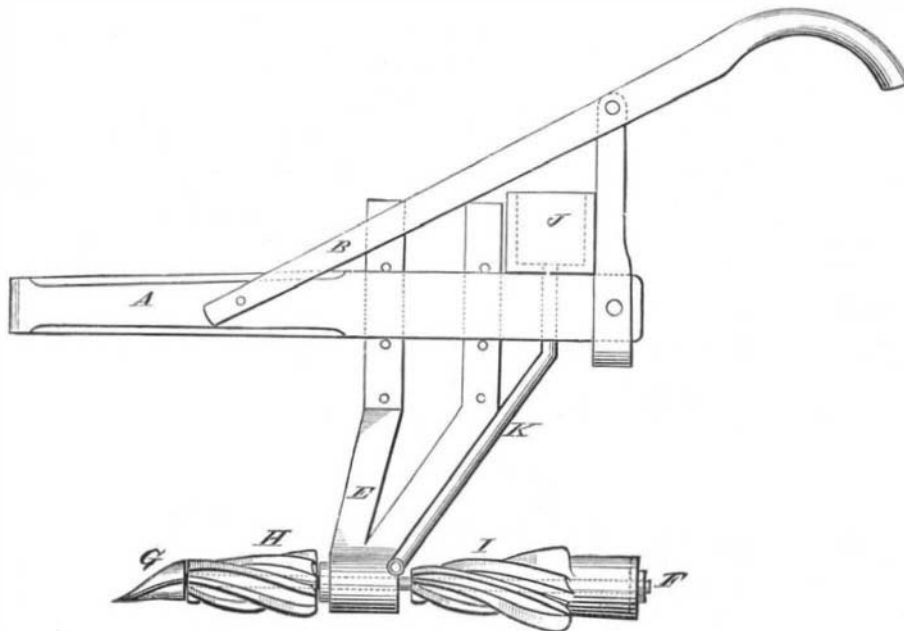

SNYDER'S DITCHING MACHINE.

elevated, the rise of the calorimetric thermometer, o, is noted. The second period is that of distillation, which lasts from 2 to 4 minutes, determining an elevation of from 3° to 4° C. in the water of the calorimeter. The latter contains some 30 ounces of water, and the weight of liquid volatilized is about 1 ounce. The lamp is then extinguished, the flask removed, cooled, and again weighed, and the exact weight of the vaporized liquid is thus determined.

The movement of the thermometer is meanwhile followed until it becomes regular—that is to say, agreeing with the cooling (previously studied) of the calorimeter, filled simply with the same weight of water at the same temperature. The data are thus obtained for calculating the problem above in-

dicated; the specific heat being known by other trials, the heat of vaporization is readily deduced. Thus, for example, M. Berthelot finds for the total heat ceded by the vapor of water (weight equaling 8.24 grammes, 6.86 grammes, and 7.08 grammes) between 0° and 100° C. (32° and 212° Fah.) the numbers 635.2, 637.2, and 636.2; average, 636.2. Regnault obtains 636.6. The inventor has used this apparatus for measuring the heat of vaporization of anhydrous and monohydrated acetic acids, monohydrated nitric acid, of chloral and its hydrate, and other substances.

**New Mechanical Inventions.**

Mr. Louis Durand, of Quebec, Canada, has secured a patent for the combination, in a Dough Mixing Machine, of a revolving ring-shaped trough of tapering body, with one or more kneaders revolving in an opposite direction to the trough, and having straight sides corresponding to the inclination of the sides of the trough, and curved intermediate sides for the purpose of thoroughly incorporating the dough.

Mr. G. W. Lewthwaite, of Fort Miller, N. Y., has made an improvement in Felt Washers for Paper Making Machines, which is intended to clean the felt without injuring it, and which consists in the combination of fluted washer rolls and a washer box with the frame and perforated water pipe of a paper making machine.

Mr. Cornelius Young, of Sandy Hill, N. Y., has invented an improved Suction Box for Paper Making Machines. It is a box designed to be arranged in close connection with the wire screen, between the "deckle" and the "dandy roll," and is provided with rollers. The invention further consists in a novel mode of exhausting air from the vacuum box, dispensing with the usual pumps.

Improvements in Adjustable Saw Teeth and Holders are the subject of a patent recently issued to Messrs. S. J. Randall and James O'Brien, of Port Ludlow, W. T. The tooth is arc-shaped, sliding by a grooved edge in a tongued recess of the saw, and retained by a split spring holder, which is grooved on three sides, seated in a recess of the saw, and provided with a projection which enters into recesses of one of the grooved edges of the tooth, so as to lock the latter by means of a pin or rivet.

An improved Steering Propeller is combined with the rudder of a vessel, and connected with the power by a shaft having universal joints, which permits the screw to be moved laterally with the rudder. This is the invention of Mr. T. F. Levens, of Cascades, W. T.

**Setting Milk.**

The Vermont Dairymen's Association has recently held a meeting, and numerous subjects of practical importance to farmers have been discussed. Among other matters, that of setting milk has received considerable attention. Mr. J. W. Williams, of Glastonbury, Conn., stated that with the Cooley creamer extreme cold was specially desirable only during the first few hours after placing the milk in the water. The cream when gathered should stand a day or two to ripen, as time in churning would thus be saved. Mr. J. F. Ferguson, of Burlington, Vt., exhibited a new pan which is set upon wheels and is large enough to hold one milking. When strained the milk is shoved back into a portable ventilated apartment, fitted with ice chamber, wire screens, convenient doors, and arrangements for skimming the milk and cooling the cream. Mr. E. S. Wood described the following experiments in setting milk at various temperatures. The trials were made in per cent glasses, the morning's milk from the same cow being set at each trial. The range of temperature is that noted during the day, no one sitting up nights to watch the experiments. At the time of making each record, the cream line was clear and distinct. At the first trial the temperature near the glasses was between 80° and 90°. In 3½ hours there was twenty per cent of cream; in 10 hours eighteen per cent, and the same at the end of 24 hours. At the second trial the mercury stood at from 35° to 40°; in 3½ hours there was forty per cent of cream, but at the end of 10 hours it had shrunk to thirty-two per cent. It was then removed to a warm room, where at the end of 24 hours it stood at twenty-two per cent. At the third trial the mercury stood at from 70° to 73°. At the end of 2 hours there was thirty-four per cent of cream, in 10 hours twenty-two per cent, and at the expiration of 24 hours but nineteen per cent.

**Neutralizing Poison.**

A poison of any conceivable description and degree of potency, which has been intentionally or accidentally swallowed, may, it is said, be rendered almost instantly harmless by simply swallowing two gills of sweet oil. A person with a very strong constitution should take nearly twice the quantity. This oil, it is alleged, will most positively neutralize every form of vegetable, animal, or mineral poison with which physicians and chemists are acquainted.