

**NEW STANDARD LIGHT AND MEDIUM GRINDING MILLS.**

In last week's issue we gave illustrations of a portable grinding mill manufactured by Edward Harrison, of New Haven, Conn., in which was shown an improved heavy 20 inch mill, with which were combined pedestal and dressing frame. In the annexed engravings we present two other patterns of mill by the same manufacturer, also embracing bases and dressing frames. The bases, however, are here cast separate from the mill cases, and are attached to them by bolts. They are thus adjustable, and obviate the necessity of frames or foundations, while the dressing frames enable one person to handle the heavy parts of the mills, in which the burrs are encased for the necessary purpose of dressing.

Fig. 1.

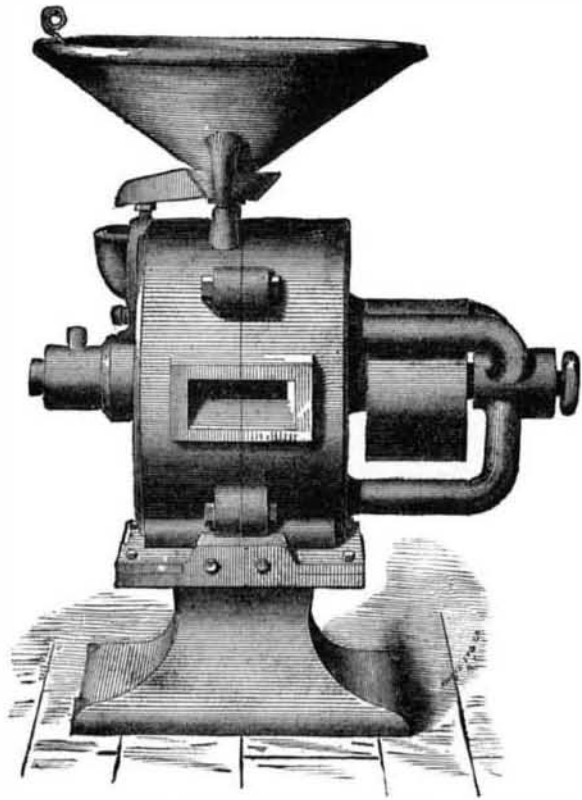

The mills illustrated, in common with all produced by the above named manufacturer, have burr stone grinders set in a vertical position and driven at high speed. They are respectively known as the new standard light and medium 20 inch mills. The grinding surface of the light mill, at 1,200 turns per minute, is claimed to be equal to one quarter more than an old style 48 inch run at 175 revolutions per minute. The grinding capacity per hour is from 6 to 40 bushels, and the weight 700 lbs. Fig. 1 shows the mill (either light or medium) with base attached, and Fig. 2, the same open for dress.

A large number of patented improvements are embodied, notably improved side hangers, duplicate discharge spouts, safety bridge trees, adjusting burrs, large oil cup, self-cooling step, besides a new safety spring box and set lever, which permits foreign substances to pass through without damage to the faces.

The grinding surface of the medium 20 inch mill, at 1,300 turns per minute, is equal, it is claimed, to one half more than an old style 48 inch run at 175 revolutions per minute. The grinding capacity per hour is from 9 to 60 bushels, and the weight 1,050 lbs. The larger mill of the two occupies a floor space of 2 feet 6 inches by 4 feet 3 inches.

In our previous article we reverted to the advantages claimed for the system of milling peculiar to these machines. It embodies vertical burrs, rigid runners, and high speed, producing large grinding surface and capacity. The construction is also substantial and durable. For further particulars address the manufacturer, Mr. Edward Harrison, No. 135 Howard Ave., New Haven, Conn.

**Woad.**

Woad is an annual which is cultivated in Europe for dyeing purposes. It furnishes a beautiful yellow color, which is specially present in the tops of the flowers. The plant comes into commerce in the form of dried bundles. M. Chevreuil has found in it a coloring matter to which he gives the name of *luteoline*. A decoction made during a quarter of an hour, with a portion of the terminal leaves mixed with pods of the woad and ten parts of boiling water, deposits, when cool, according to M. Chevreuil, flakes of a slight olive brown yellow, which are formed of luteoline, of a crystallizable white matter, an azote matter, oxide of iron, lime, and silic. When the decoction is filtered it is a reddish yellow. It has a disagreeable and peculiar odor, with a sweet bitter taste. It only affects glue slightly, and is acid with sunflower paper. To these characteristics Chevreuil adds the following: It contains sulphate of lime and chloride of calcium in small quantity, and a great deal of

soluble salts with a lime basis. Potash changes the color from golden yellow to a greenish shade. Baryta gives a flaky precipitate of a fine yellow. Alum gives a slight yellow precipitate. The hydrochlorate of protoxide of zinc, and especially the acetate of lead, give a more abundant yellow precipitate. The precipitate which is formed by the acetate of copper is a red approaching to green. The sulphate of protoxide of iron colors it an olive brown, and only leaves a slight brown precipitate. Sulphuric acid concentrates the color in red and precipitates some flakes; when the acid is weak it only roils it.

Nitric acid without precipitating darkens its color. Oxalic acid precipitates the oxalate of lime, and the filtered liquid is of a very pale yellow. Acetic acid without precipitating weakens its color, but much less so than oxalic acid. The watery solution of iodine produces nothing remarkable. A little chlorine changes the color red and precipitates flakes. If an excess is exhibited the red disappears, and the liquid changes to yellow. The luteoline, the coloring matter which M. Chevreuil has extracted from the woad, can be sublimated in needles; the largest are transparent and of a light yellow; the smallest, as seen on the surface of the glass where they condense, seem of a deeper yellow and have a velvety appearance. Its reaction on litmus is rather acid than alkaline. It is very soluble in water, and although it scarcely colors this liquid, it gives it the property of dyeing silk and wool (which have been impregnated with alum, and which are put into it at a slightly elevated temperature) a fine greenish yellow. It is soluble in alcohol and in ether. A watery solution of potash colors it a splendid gold yellow, which gradually changes to greenish yellow, then russet, by absorbing oxygen. The solutions of baryta, strontium, lime, and ammonia, act in a similar manner.

The acetate of lead, alum, and the acetate of copper precipitate its watery solution yellow. The sulphate of peroxide of iron precipitates it an olive brown. Concentrated sulphuric acid develops a yellow color which approaches red rather than green.

Gradually red flakes are produced. The concentrated nitre acid, in which it is diluted, will dissolve it; the solution is of a greenish-orange yellow; it precipitates by water. The volatility of the coloring matter and its resistance to the action of concentrated acids place it among the most stable substances of this order. M. Chevreuil has found qualities in it very similar to the coloring matter of quercitron and rosewood. By applying his process to the decoction of woad, M. Preisser obtains a clear yellow liquor, which, on cooling, throws down a large quantity of yellowish white scales; large yellow scales are obtained on boiling with some drops of chromic acid; they are similar to iodide of lead. The yellow matter is the luteoline; it is presented in the shape of white scales, which are soluble in water.

**Gutta Percha Capsules.**

A useful purpose to which benzole may be put as a solvent is in dissolving the little scraps and odd pieces of gutta percha tissue, which in the ordinary course of business will accumulate, and which are too frequently thrown aside as waste and useless. If these be dissolved by the aid of a gentle heat, so as to form a moderately thick fluid, and then vermilion or other pigment added, both for the purpose of coloring the solution and giving it a greater body, a preparation is obtained capable of producing a uniform and a very superior film. The purposes to which such a solution may be applied are various, but one in particular suggests itself,

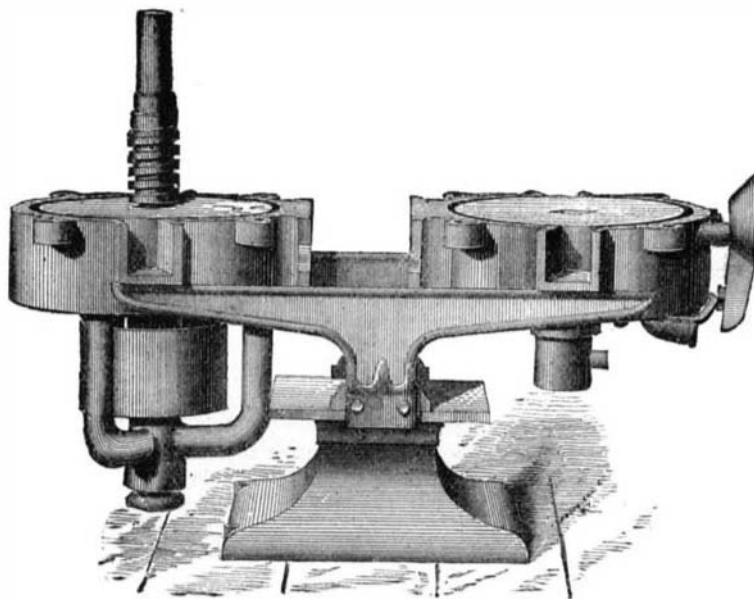
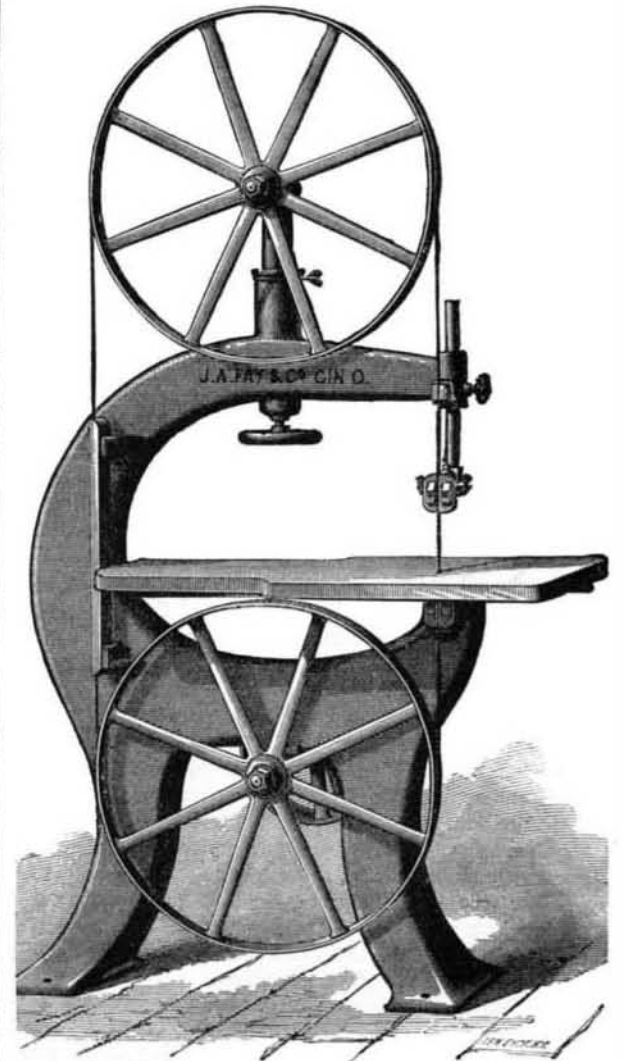

Fig. 2.—HARRISON'S NEW STANDARD GRINDING MILLS.

namely, as a capping for bottles. In thus employing it the solution may either be brushed over the top, or better still, the top of the bottle may be dipped into it, as bottles are dipped into sealing wax, and then put aside to set. The gutta percha capsule thus obtained is impervious to air, water, oil, spirit, and indeed most liquids, tears cleanly off when required, and has the further great advantages of cheapness, simplicity, and neatness. No better or neater finish could, we think, be given to liquid patent and proprietary medicines than a gutta percha capsule prepared to this manner.—*Chemist and Druggist*.

**NEW IMPROVED BAND-SAWING MACHINE.**

Band-sawing machines are in such universal use that the demand for them induces manufacturers to make changes to meet some newly developed want which may be discovered, and obtain prominence amongst operators of band saws. The varying changes in the form of machines, methods of producing flexibility in the motion of the upper saw wheel sufficient to prevent breakage of saws by any sudden varia-



tion in the tension of the saw, or leaving off some device used for a special purpose and not desired generally, thereby lessening the cost of construction, are, we think, worthy of notice.

We illustrate herewith a new band-sawing machine, the object of which is to meet the requirements of the demand for a machine of small cost with the adaptability to general classes of work.

The column of the machine is cast in one solid piece, forming a support to the wheels and table, of such proportions as to resist all inclination to vibration or flexure. The bearings of the wheels are long and arranged to avoid the wear incident to the revolution of their shafts.

The upper wheel bearing is supported upon a turned center, movable vertically in the column to compensate for differences in the lengths of the saws from breakage or other causes. It is raised and lowered by a screw and hand wheel. The upper wheel has a device attached to its support to direct the saw in its line of travel on the wheels, by a revolution of the upper wheel on a horizontal plane through the center of the axis of the wheel, thus placing the upper wheel at an angle to the lower wheel to give the saw sufficient lead to retain a constant pressure of its back against the guide rollers. The wheels are covered with an elastic covering to protect the teeth of the saw from abrasion, and to assist in compensating for variations in the tension of the saw blade.

The saw guides upon this machine are of the same pattern as those placed upon all band-sawing machines built by this house. They consist of a hardened steel roller which revolves as the back of the saw passes over it, relieving the saw from the friction caused by the back thrust, thereby obviating the most prominent cause of the fracture of band-saw blades. The saw is held in position by adjustable side guides, which can be regulated to accommodate different thicknesses and widths of blades. The upper guide is attached to a vertical bar which is adjustable to the thickness of the work sawing; the lower guide is attached to the column. Patented August 14th, 1877. For further information, address J. A. Fay & Co., Cincinnati, O.

THE flame of a mixture of two volumes of coal gas with three of carbonic acid gave a maximum heat of 1,000°. One volume of coal gas with two of carbonic acid gave 860°, while the maximum temperature reached with the flame of one volume of coal gas and three of carbonic acid was 780°. Mixtures of coal gas and atmospheric air decrease in heat if the proportion of the latter exceeds what is necessary for combustion.—*F. Rossetti*.